

Kuzinovski, M., Trajčevski, N., Cichosz, P., Tomov, M.

MONITORING SYSTEM FOR INVESTIGATION OF THE CUTTING FORCES IN THE MACHINING WITH TURNING

Abstract: In this paper, a research system designed for measuring the forces in the cutting process is represented. It is created as result of a modernization of an already existing inductive dynamometer model FISHER MESSTECHNIK TYP EF2 D3 NR 24570 with an interface for a personal computer. The interface provides amplifying and acquisition of the signals for the components of the resultant cutting force and forwarding the data toward the personal computer. Monitoring, control and processing of the data from the inductive dynamometer and acquisition of the dynamic character of the components from the cutting process resultant force are enabled.

Key words: monitoring, forces, machining, turning

1. INTRODUCTION

It is necessary to know the size of the cutting force in the machining process with turning mainly for definition of the strength of the cutting tool, the limit of the maximum loading of the cutting machine, prediction of the cutting edge wearing, optimization of the cutting tool stereometry, managing chip forms and the lead away direction, and also for the expected results of the machining [1,2]. The experiences show that determining the cutting forces analytically does not fully show the real situation. The mathematical models for the cutting force received analytically are based on tabular data, which are acquired through experimental researches conducted in certain machining conditions, which can be changed. This is the reason for the justification of creating a research system for determining of the cutting force components by an experimental way [3]. A modernized monitoring system for researching the cutting force in the machining with turning is described in this paper.

2. DESCRIPTION OF THE MONITORING SYSTEM

The monitoring system represented on Figure 1 is created with an upgrade of an already existing inductive dynamometer model FISHER MESSTECHNIK TYP EF2 D3 NR 24570.

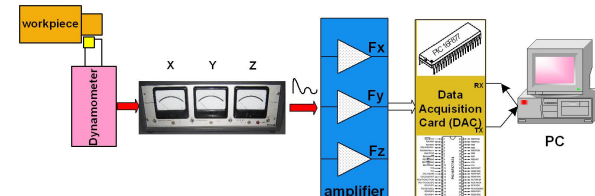

Figure 1. Monitoring system for investigation of cutting forces in the machining process with turning

The principle of work of this measuring system is with an imbalance of measuring bridge for every component separately. Because of the fact that the mentioned installation is of an old-fashioned type, where the influence of the human factor during the reading and recording of the values is not excluded, the installation is being modernized. Another reason for the modernization is the obstructed performance of the experiments and even an impossible reading of the values of all the components simultaneously. Through the modernization of the inductive dynamometer, we were guided by the new technological trend called mechatronics, which

denotes a multi-disciplined approach towards the integral projection and development of new products and systems. It can also be used in the creation of science researching systems. In this case, because of the specific construction of the measuring system for measuring the tangential, axial and radial component of the cutting force the measuring system was upgraded without any disruption of its functionality in any of its parts and just using it as a source of signals. This measuring system is connected to a personal computer. Software, which enables handling the highest level of automation is also made. The connection is made with an interface whose task is to accept signals from the measuring instrument, to adjust them for digitalization, to perform an acquisition on them and to forward them in a digital form to the personal computer. From the dynamometer analysis, it is concluded that the most convenient way to take the information on the size of the cutting force which is transformed into an electrical signal with a change of the opening of the differential transmitter is to be taken from the indicator leads. The signal has a pulse form and its voltage level is on +2.2 V in reference to the ground point, Figure 2.

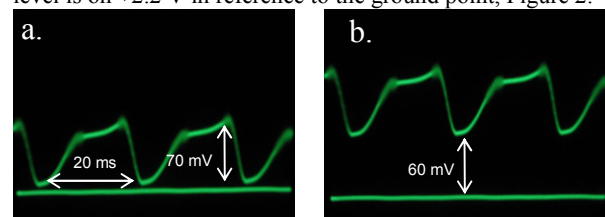

Figure 2. Waveform of the signal on the ends of the indicator
a) When in null position of the arrow b) When in drift of the arrow

The design of the electrical scheme of the amplifier whose task is to prepare the signal for acquisition is performed with the CircuitMaker Demo Software, Figure 3. The signal, shown on Figure 2, is taken from the indicator leads by a voltage follower constructed with the operational amplifier TL084.

Infinite high input impedance of the voltage follower enables connection on the measuring bridge without any influence on it. After this, the signal is taken to the differential amplifier. The differential amplifier outputs voltage level that is proportional to the difference of the voltage levels on the indicator leads. That provides a signal, which is proportional to the change of the opening of differential transmitter, because the indicator current is proportional to the imbalance of the measuring bridge whose integral component are the differential transmitter and the indicator. The highest voltage level that will appear on the output from the differential

amplifier corresponds with the biggest voltage difference which can appear on the indicator leads. The indicator is an amperemeter which characteristics are: maximum current of 100 μA and internal resistance of 1750 Ω . That means that the biggest voltage difference, which will appear on the indicator, leads is 17.5 mV. To amplify this voltage level for the needs of the acquisition which is performed in the interval of 0-5 V an inverting amplifier consisted of the operational amplifier TL084 is used with a nominally adjusted gain of 21. The expected maximum value of the signal on the output of the inverting amplifier is 3.7 V.

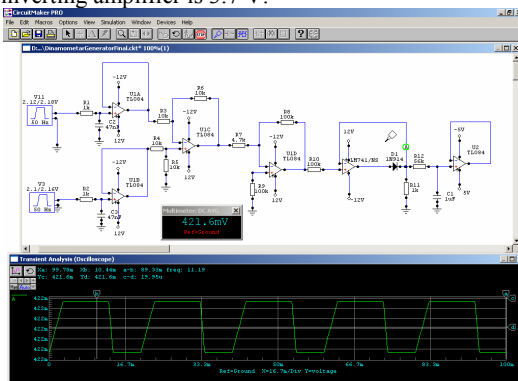

Figure 3. Screen dump of the simulator that is used for designing the amplifier.

On the output of the inverting amplifier exist also a possibility for an occurrence of negative values of the voltage when an eventual displacement of the differential transmitter occurs in an opposite direction (out of the cutting process). The blocking of the negative values of the signal with a purpose of protecting the components for acquisition which do not function with negative values is performed with the structure of precise diode consisted of the operational amplifier LM741 and the 1N914 diode. On the end of the amplifier is set another voltage follower, but in this case it is supplied with power of $\pm 5\text{V}$ to provide a limit for the maximum level of the output signal on +5V. With this voltage follower the influences of the circuit for the acquisition on the amplifier's work are removed. On the input of the voltage follower the capacitor is connected with a purpose to level the pulse form. Then the signal is acquisitioned with A/D converter, which is a part of the integrated circuit (IC) PIC16F877. This IC have an built-in 10-bit A/D converter with an ability for defining intern or extern voltage references and it is possible to make 8-channel digitalization. The maximum frequency of the tact generator is 20 MHz. The microcontroller enables 50000 conversions per second. The nature of our researches during which the cutting force is considered as a static dimension for a certain conditions of machining has imposed a need for taking a few samples of the signal per one turn of the workpiece [4]. For adopted maximum 2000 turns per minute and 5 samples of the signal per turn, the system should perform a conversion and acquisition on $2000 \times 5 / 60$, that is to say 167 samples per second for every component, which is far below the possibility of the chosen system. The microcontroller contains an integrated module for serial synchronous and asynchronous communication simultaneously in both directions, USART (Universal Synchronous Asynchronous Receiver Transmitter) with ability for easy adjustment of the speed of communication. It was decided a speed of communication of 115200 bps to be used because this speed enables flow of a maximum number of data through the line of communication. According to the fact that every sample takes $2 \times 8 = 16$ bits, in this regime we could "in real time" transport $115200 / 16 = 7200$ samples which is much more than the number needed, using even 4 channels simultaneously. This way of sending the data on the personal computer avo-

the procedure of temporary recording of the data in the microcontroller system and enabling the data flow to be performed in "real time"[5]. Designed application in Microsoft Visual C++, receives the data through RS232 interface of personal computer. The window of the application shown on Figure 4 is divided into two parts. One of the parts has a grid that enables a graphical interpretation of the dynamical character of the components of the cutting force and determining the length of the time axis in which the average value of the cutting force components are calculated. The other part of the window, denoted with an arrow on Figure 4, contains a set of controls designed for adjusting and showing the specific average values on a previously chosen length of the time axis. The monitoring system is calibrated by loadings in range of 0-1kN.

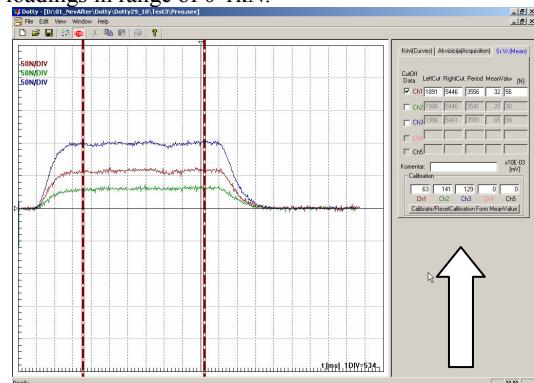

Figure 4. Screen dump of the monitoring system software.

3. CONCLUSION

The created monitoring system for investigation of the cutting forces has characteristics that include full access to the hardware and the software. It is used mechatronic approach in the process of modernization of the existed equipment. Performing continual development activities in the building of the monitoring system have been enabled. The valid choice of the applied hardware and software solutions is confirmed by the measurement uncertainty of the obtained results during monitoring system calibration. There have been achieved conditions for conducting research activities during high intensive transformation of the workpiece material into chips, which is characteristics of the machining by high cutting speed and new cutting materials.

4. REFERENCES

- [1] Kuzinovski, M., Pavlovski, V., Zebrovski, H., Cichosz, P.: *Razvoj na metodika i laboratoriska oprema za izveduvanje na analiticko eksperimentalni istrazuvanja vo oblasta na obrabotkata so rezenje*, Ministerstvo za nauka, RM, 1997.
- [2] Bogdan, M., Streubel, A., Szawdzin, K.: *Computer drilling forces measurement system*, Prace Naukowe Instytutu Technologii Maszyn i Automatyzacji Politechniki Wroclawskiej, p.p. 303-306, 1993.
- [3] Nedić, B, *Razvoj monitoring sistema za istrazivanja u procesima obrade metala rezanjem*, Šesta Jugoslovska konferencija o tribologiji, YUTRB '99, p.p. 45, Kragujevac, 1999.
- [4] Bernat, P., Grzesik, W.: *Diagnostic signals processing using multi-sensor measurement system*, VIII Konferencja Naukowo-Techniczna: "Metrologia w Technikach Wytwarzania Maszyn", p.p. 455-462, Szczecin, 1999.
- [5] Trajčevski, N., Filiposki, V., Kuzinovski, M., *Personal computer interface for temperature measuring in the cutting process with turning*, Proceedings, Faculty of Mechanical Engineering, Skopje, Vol.23, No.2, p.p.65-74, 2004.

Authors: Prof.Dr. Kuzinovski Mikolaj, Trajčevski Neven, prof., Tomov Mite, dipl.ing. University "Ss. Cyril and Methodius", Faculty of Mechanical Engineering, Skopje, R.Macedonia. E-mail: mikolaj@mf.ukim.edu.mk

Prof.Dr. Cichosz Piotr, ITMiA of the Wrocław University of Technology, Wrocław, Poland.