

GOCE DELCEV UNIVERSITY - STIP
FACULTY OF COMPUTER SCIENCE

ISSN 2545-4803 on line

DOI: 10.46763/BJAMI

BALKAN JOURNAL
OF APPLIED MATHEMATICS
AND INFORMATICS
(BJAMI)



YEAR 2025

VOLUME 8, Number 2

AIMS AND SCOPE:

BJAMI publishes original research articles in the areas of applied mathematics and informatics.

Topics:

1. Computer science;
2. Computer and software engineering;
3. Information technology;
4. Computer security;
5. Electrical engineering;
6. Telecommunication;
7. Mathematics and its applications;
8. Articles of interdisciplinary of computer and information sciences with education, economics, environmental, health, and engineering.

Managing editor

Mirjana Kocaleva Vitanova Ph.D.

Zoran Zlatev Ph.D.

Editor in chief

Biljana Zlatanovska Ph.D.

Lectoure

Snezana Kirova

Technical editor

Biljana Zlatanovska Ph.D.

Mirjana Kocaleva Vitanova Ph.D.

**BALKAN JOURNAL
OF APPLIED MATHEMATICS AND INFORMATICS
(BJAMI), Vol 8**

**ISSN 2545-4803 on line
Vol. 8, No. 2, Year 2025**

EDITORIAL BOARD

- Adelina Plamenova Aleksieva-Petrova**, Technical University – Sofia,
Faculty of Computer Systems and Control, Sofia, Bulgaria
- Lyudmila Stoyanova**, Technical University - Sofia , Faculty of computer systems and control,
Department – Programming and computer technologies, Bulgaria
- Zlatko Georgiev Varbanov**, Department of Mathematics and Informatics,
Veliko Tarnovo University, Bulgaria
- Snezana Scepanovic**, Faculty for Information Technology,
University “Mediterranean”, Podgorica, Montenegro
- Daniela Veleva Minkovska**, Faculty of Computer Systems and Technologies,
Technical University, Sofia, Bulgaria
- Stefka Hristova Bouyuklieva**, Department of Algebra and Geometry,
Faculty of Mathematics and Informatics, Veliko Tarnovo University, Bulgaria
- Vesselin Velichkov**, University of Luxembourg, Faculty of Sciences,
Technology and Communication (FSTC), Luxembourg
- Isabel Maria Baltazar Simões de Carvalho**, Instituto Superior Técnico,
Technical University of Lisbon, Portugal
- Predrag S. Stanimirović**, University of Niš, Faculty of Sciences and Mathematics,
Department of Mathematics and Informatics, Niš, Serbia
- Shcherbacov Victor**, Institute of Mathematics and Computer Science,
Academy of Sciences of Moldova, Moldova
- Pedro Ricardo Morais Inácio**, Department of Computer Science,
Universidade da Beira Interior, Portugal
- Georgi Tuparov**, Technical University of Sofia Bulgaria
- Martin Lukarevski**, Faculty of Computer Science, UGD, Republic of North Macedonia
- Ivanka Georgieva**, South-West University, Blagoevgrad, Bulgaria
- Georgi Stojanov**, Computer Science, Mathematics, and Environmental Science Department
The American University of Paris, France
- Iliya Guerguiev Bouyukliev**, Institute of Mathematics and Informatics,
Bulgarian Academy of Sciences, Bulgaria
- Riste Škrekovski**, FAMNIT, University of Primorska, Koper, Slovenia
- Stela Zhelezova**, Institute of Mathematics and Informatics, Bulgarian Academy of Sciences, Bulgaria
- Katerina Taskova**, Computational Biology and Data Mining Group,
Faculty of Biology, Johannes Gutenberg-Universität Mainz (JGU), Mainz, Germany.
- Dragana Glušac**, Tehnical Faculty “Mihajlo Pupin”, Zrenjanin, Serbia
- Cveta Martinovska-Bande**, Faculty of Computer Science, UGD, Republic of North Macedonia
- Blagoj Delipetrov**, European Commission Joint Research Centre, Italy
- Zoran Zdravev**, Faculty of Computer Science, UGD, Republic of North Macedonia
- Aleksandra Mileva**, Faculty of Computer Science, UGD, Republic of North Macedonia
- Igor Stojanovik**, Faculty of Computer Science, UGD, Republic of North Macedonia
- Saso Koceski**, Faculty of Computer Science, UGD, Republic of North Macedonia
- Natasa Koceska**, Faculty of Computer Science, UGD, Republic of North Macedonia
- Aleksandar Krstev**, Faculty of Computer Science, UGD, Republic of North Macedonia
- Biljana Zlatanovska**, Faculty of Computer Science, UGD, Republic of North Macedonia
- Natasa Stojkovik**, Faculty of Computer Science, UGD, Republic of North Macedonia
- Done Stojanov**, Faculty of Computer Science, UGD, Republic of North Macedonia
- Limonka Koceva Lazarova**, Faculty of Computer Science, UGD, Republic of North Macedonia
- Tatjana Atanasova Pacemska**, Faculty of Computer Science, UGD, Republic of North Macedonia

TABLE OF CONTENTS

| | |
|--|-----|
| Aleksandra Risteska-Kamcheski SOLUTION OF DIDO’S PROBLEM USING VARIATIONS | 7 |
| Mirjana Kocaleva Vitanova, Elena Karamazova Gelova, Zoran Zlatev, Aleksandar Krstev ENHANCING GEOGRAPHIC INFORMATION SYSTEMS WITH SPATIAL DATA MINING | 19 |
| Violeta Krcheva, Misa Tomic ADVANCED TOOLPATH VERIFICATION IN CNC DRILLING: APPLYING NEWTON’S INTERPOLATION THROUGH MATLAB | 31 |
| Martin Tanchev, Saso Koceski WEB-BASED EDUCATIONAL GAME FOR EARLY SCREENING AND SUPPORT OF DYSCALCULIA | 43 |
| Maja Kukuseva Paneva, Elena Zafirova, Sara Stefanova, Goce Stefanov MONITORING AND TRANSMISSION OF THE PROGRESS PARAMETERS ON AGRO INDUSTRIAL FACILITY IN A GSM NETWORK | 55 |
| Qazim Tahiri, Natasa Koceska METHODS OF EXTRACTION AND ANALYSIS OF PEOPLE’S SENTIMENTS FROM SOCIAL MEDIA | 69 |
| Ana Eftimova, Saso Gelev DESIGN AND SIMULATION OF A SCADA – CONTROLLED GREENHOUSE FOR OPTIMIZED ROSE CULTIVATION | 81 |
| Milka Anceva, Saso Koceski A FHIR – CENTRIC APPROACH FOR INTEROPERABLE REMOTE PATIENT MONITORING | 93 |
| Jordan Pop-Kartov, Aleksandra Mileva, Cveta Martinovska Bande COMPARATIVE EVALUTION AND ANALYSIS OF DIFFERENT DEEPPFAKE DETECTORS | 103 |
| Vesna Hristovska, Aleksandar Velinov, Natasa Koceska SECURITY CHALLENGES AND SOLUTIONS IN ROBOTIC AND INTERNET OF ROBOTIC THINGS (IoRT) SYSTEMS: A SCOPING REVIEW | 115 |
| Violeta Krcheva, Misa Tomic CNC LATHE PROGRAMMING: DESIGN AND DEVELOPMENT OF A PROGRAM CODE FOR SIMULATING LINEAR INTERPOLATION MOTION | 127 |
| Jawad Ettayb NEW RESULTS ON FIXED POINT THEOREMS IN 2-BANACH SPACES | 139 |

CNC LATHE PROGRAMMING: DESIGN AND DEVELOPMENT OF A PROGRAM CODE FOR SIMULATING LINEAR INTERPOLATION MOTION

VIOLETA KRCHEVA AND MIŠA TOMIĆ

Abstract. This paper builds upon the foundational work of simulating linear interpolation motion in CNC turning by advancing into the realm of CNC lathe programming. It focuses on the design and development of a program code specifically tailored for simulating linear interpolation motion. By integrating G-code programming techniques with advanced simulation tools, this study provides a robust framework for visualizing and analyzing the precise motion paths in CNC lathe operations. The results contribute to improved accuracy and efficiency in CNC machining processes, offering valuable insights for both academic research and practical applications in the field of CNC programming.

1. Introduction

The Computer Numerical Control (CNC) technology has revolutionized modern manufacturing, enabling highly precise and automated machining processes. Among the various operations performed on CNC machines, turning is a fundamental process widely used for producing cylindrical parts. The efficiency and accuracy of CNC turning are significantly influenced by the quality of the programming that controls the machine's movements. In this context, the development of effective programming techniques, particularly for simulating motion, becomes crucial for optimizing CNC operations [1].

Metal cutting processes form the backbone of modern manufacturing, enabling the transformation of raw materials into finished products with intricate geometries and tight tolerances. These processes involve the controlled removal of material from a workpiece using cutting tools, where the quality of the final product is heavily dependent on factors such as cutting speed, feed, cutting tool geometry, and material properties. In CNC operations, metal cutting is performed with high precision, governed by pre-programmed instructions that dictate the toolpath, depth of cut, and other parameters. The ability to simulate these processes accurately is vital for ensuring that the machining operations will yield the desired outcomes in terms of surface finish, dimensional accuracy, and material integrity [2].

Material removal processes are a subset of metal cutting operations that specifically focus on the elimination of excess material from a workpiece to achieve the final desired shape. These processes are characterized by their reliance on precise cutting tool movements to cut off material in the form of chips, and they are integral to CNC machining. In turning, which is a type of material removal process, the workpiece rotates while the cutting tool systematically removes material to create cylindrical shapes (Fig. 1). The effectiveness of material removal is influenced by various factors, including

Date: July 18, 2025.

Keywords. Material removal, Metal cutting, Turning, G-codes, Program blocks.

cutting tool wear, cutting forces, and thermal effects. Accurate programming of these processes is essential for optimizing efficiency and minimizing waste, making simulation a critical tool in the development and validation of CNC programs.

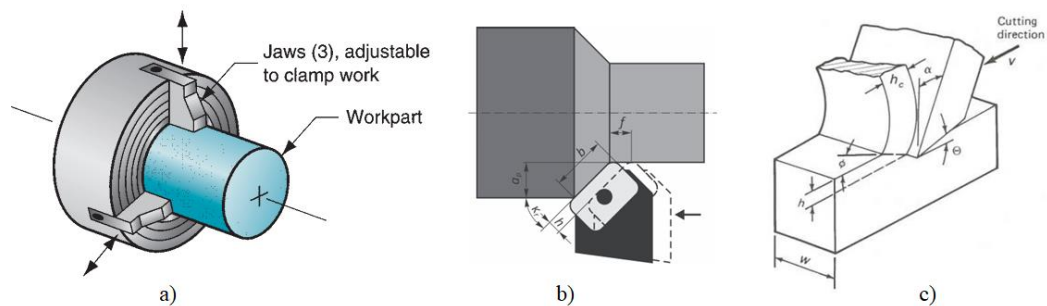

Figure 1. a) Three-jaw lathe chuck [3], b) Turning principle [4], c) Chip removal [5]

CNC programming involves the development of programs that control CNC machines by converting design specifications into a series of commands for performing turning operations. These programs comprise a structured set of instructions that the CNC machine interprets and implements, utilizing G-codes and M-codes to control the machine's various moving components throughout the manufacturing process.

Each instruction is organized into a 'program block', which represents an individual line of code within the CNC program (Fig. 2). A typical program block includes commands that govern specific machine functions, such as tool movement, spindle speed, or coolant activation. The sequential arrangement of these program blocks ensures that the machine performs the required operations in the correct order, executing each step with precision.

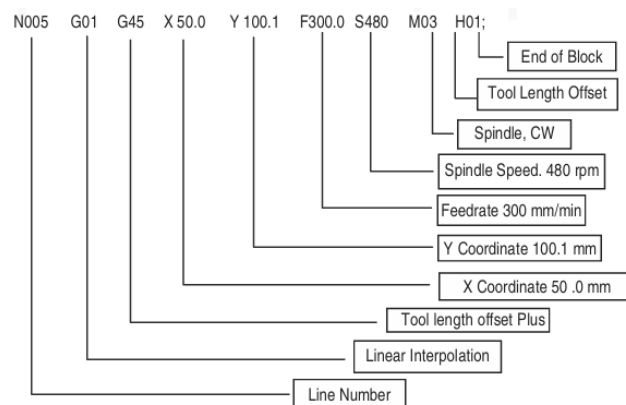

Figure 2. Typical program block [6]

G-codes are the specific commands within a CNC program that control the movements of the machine's cutting tools. Each G-code corresponds to a particular action, such as moving the cutting tool to a new position, changing the feed, or performing a specific type of interpolation. The correct use of G-codes is essential for precise control over the machining process, as they directly influence the toolpath and behavior of the cutting tool. In the development of CNC programs for turning, a deep understanding of G-codes is required to ensure that the cutting tool follows the intended trajectory accurately.

M-codes are complementary to G-codes in CNC programming, providing additional commands that control machine functions such as starting or stopping the spindle, turning on coolant, or changing cutting tools. While G-codes primarily dictate the motion and cutting operations, M-codes manage the auxiliary functions that are essential for the overall operation of the CNC machine. The proper integration of M-codes into a CNC program is crucial for coordinating various machine functions and ensuring that the machining process proceeds smoothly without interruptions.

In the context of CNC turning, simulating linear interpolation motion is particularly important as it ensures that the programmed toolpath is accurately followed, resulting in a precise and smooth cutting process. The insights gained from simulating interpolation contribute to the development of more efficient and accurate CNC programs, ultimately enhancing the overall quality of the machining process. The combination of accurate interpolation and thorough simulation leads to superior finished products with higher dimensional accuracy, better surface finishes, and improved overall performance [7].

The previous paper, titled 'Simulation of Linear Interpolation Motion in CNC Machining', laid a strong foundation in this area by offering a detailed analysis and simulation of linear interpolation within the CNC turning process. Through a combination of G-code utilization and visualization techniques, the paper provided an understanding of the dynamics involved in linear interpolation. This work highlighted the importance of simulation in enhancing clarity and applicability, ultimately driving innovation and optimization in CNC turning [8].

Drawing on previous research methodologies, this paper shifts focus to the practical aspects of programming. While earlier work emphasized theoretical and analytical aspects of simulation, this study concentrates on developing program codes for simulating linear interpolation motion on a CNC lathe. Based on mechanical engineering literature on CNC machines, machining processes, and related simulations (e.g., [1]–[8]), the paper is structured into four sections: introduction, research description, results discussion, and conclusion with potential applications.

2. Research

In this study, a particular facet of the machining process for a clutch hub is examined, with a focus on its application in CNC turning operations. The clutch hub is a vital element of a clutch system, integral to the clutch disc assembly, and essential for the functionality of vehicles with manual transmission. Its substantial impact on the performance and reliability of the transmission system underscores the critical importance of accuracy in

its manufacturing process. Achieving high precision is crucial, as any deviation could potentially undermine the vehicle's efficiency and safety.

To support a comprehensive examination of the turning process, 2D drawings were developed utilizing AutoCAD, an advanced computer-aided design (CAD) software. These drawings visually delineate the machining process, capturing the transformation of the clutch hub from the initial workpiece, a forged clutch hub (Fig. 3a), to the final machined clutch hub (Fig. 3b). This technical documentation is essential for a sophisticated understanding of the degree of accuracy necessary in CNC turning. Moreover, it plays a critical role in verifying that the manufacturing process complies with the rigorous quality standards expected by the automotive industry.

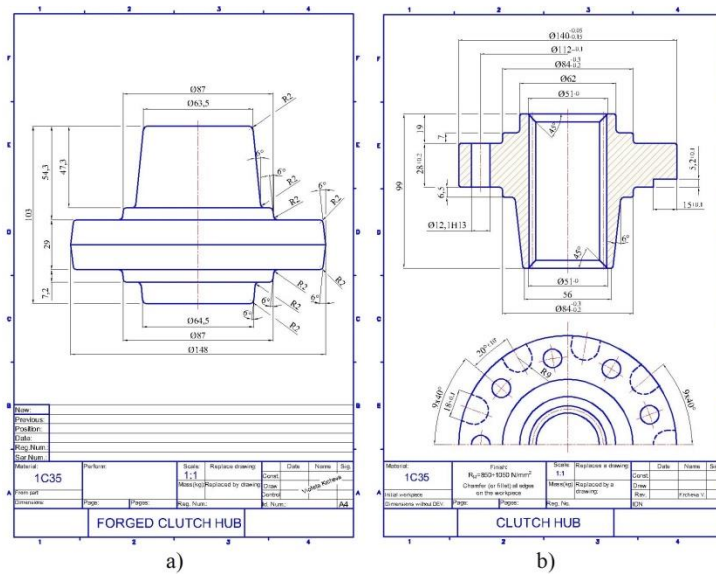

Figure 3. a) Initial forged workpiece; b) Completed clutch hub [8]

The CNC turning process (Fig. 4) includes not only the primary turning operation but also additional operations such as facing and chamfering, which are crucial for achieving precise dimensions and surface finish. The facing operation is especially critical as it produces a flat surface perpendicular to the workpiece's rotational axis, establishing a reference surface essential for accurate alignment and positioning in further machining operations. Chamfering is used to eliminate sharp edges and create angled bevels on the workpiece.

This process is crucial not only for aesthetics but also for functionality, as it facilitates assembly and enhances the component's durability. Accurate chamfering reduces stress concentrations and potential failure points in the final product. Thus, both facing and chamfering are vital for producing the clutch hub, ensuring it meets stringent dimensional tolerances and surface quality necessary for its performance and reliability.

Then, the workpiece coordinate system for the CNC lathe was established by setting its origin point, characterized by X, Y, and Z coordinates, as the foundational reference for all measurements. This origin was strategically located at the highest central point on the surface of the workpiece. With the coordinate framework in place, the next phase involved planning the toolpaths for the turning process. This planning required detailed determination of the trajectories and profiles the cutting tool needed to follow, encompassing aspects such as diameters, fillets, chamfers, and various other geometric features.

The creation of CNC programs necessitated a comprehensive series of steps to ensure that the cutting tool precisely adhered to the geometry and contours of the designed workpiece. This process commenced with a thorough analysis of the workpiece's CAD model design, which included an examination of the two-dimensional design specifications detailing all dimensional requirements, tolerances, and surface finish criteria.

To establish the toolpath for the cutting tool, a series of program blocks was formulated using G-code. This code directs the movement of the CNC lathe's moving components along the X, Y, and Z axes, defining the required motion toolpaths. Moreover, M-codes were utilized to manage various supplementary functions of the CNC lathe, such as executing tool changes, controlling coolant flow, configuring cutting conditions, and controlling spindle function.

The comprehensive program of instructions for this CNC turning process is described in detail below [8].

Program of instructions

```
%
O0001
N10 G21 G17 G40 G50 G94
N20 G50 S1000
N30 T0101
N40 M06
N50 G00 X0. Y5. M08
N60 G01 X0. Y-28. F100.
N70 G01 X-1. Y-29.
N80 G01 X-45.5 Y-34.
N90 G01 X-45.5 Y-41.
N100 G01 X-46.5 Y-42.
N110 G01 X-52. Y-42.
N120 G01 X-52. Y-69.
N130 G01 X-53. Y-70.
N140 G00 X0. Y5. M09
N150 M30
%
```

The program was further incorporated into sophisticated simulation software, where it assumed a pivotal role in the analysis and visualization of the cutting tool's performance under defined conditions that closely interpret real-world operational scenarios during the process. This integration allowed for a thorough examination of the cutting tool's functionality, taking into account the various parameters as well as limitations that are typically experienced in practical machining settings.

In particular, within the framework of CIMCO Edit 2024 simulation software, the toolpath for the CNC turning process is depicted graphically, demonstrating the consecutive movements between coordinates that are precisely defined in the CNC program (Fig. 6).

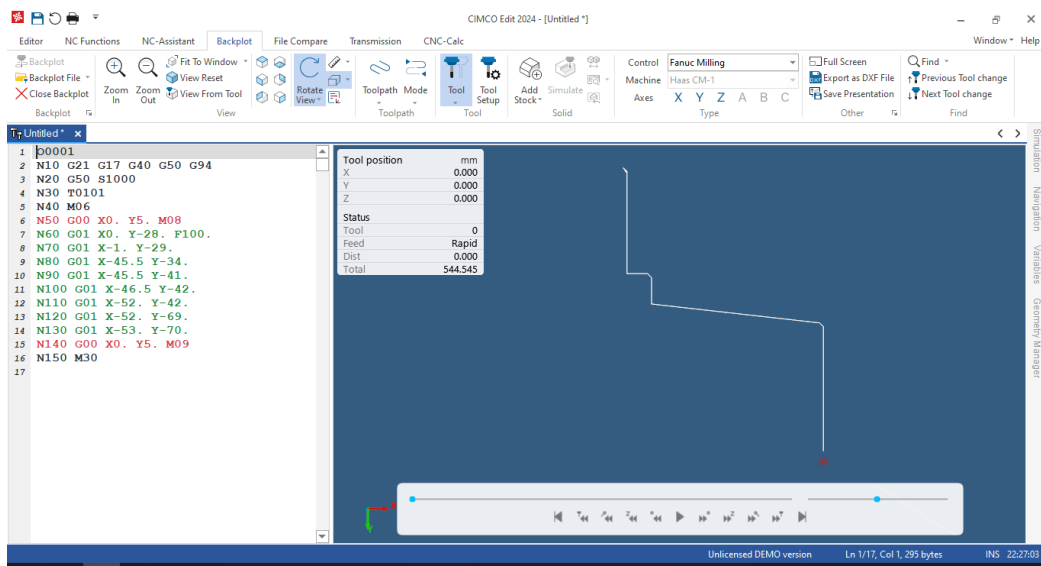

Figure 6. CNC program visualization in CIMCO Edit 2024 [8]

This graphical depiction is crucial for gaining an in-depth and nuanced understanding of the process. It provides valuable insights into how these movements, when examined collectively, shape the toolpath and influence the associated interpolation motions. By visualizing these movements, the software enhances comprehension of the cutting tool's trajectory and underscores the precision necessary in the CNC turning process.

3. Results and discussion

This section presents the analysis and discussion of the CNC program developed for the CNC turning process under specified conditions. The program is designed to operate and control the CNC lathe through a precise sequence of instructions that target the

machining of the longer side of the clutch hub. It begins and ends with a '%' symbol, marking the start and end of the program, respectively.

The program is structured to perform turning, facing, and chamfering operations, utilizing G-code, the standardized language for controlling CNC machining. For better understanding of its functionality, a systematic analysis is provided.

The CNC program initiates with the designation 'O0001', which indicates the commencement of a machining sequence. The initial command, 'G21', configures the CNC lathe to operate in millimeters, which ensures that all dimensions and movements are interpreted according to this metric system. The 'G17' command subsequently selects the XY plane for the machining operation. This choice is typical in turning operations where the cutting tool movement is confined to these two dimensions, facilitating precise control over the toolpath.

To ensure that no residual cutting tool compensation affects the current operation, the 'G40' command is used to cancel any previously applied cutting tool radius compensation. This step is crucial as it negates any adjustments to the toolpath that were made in earlier operations, thereby ensuring that the current machining process is not influenced by residual compensation settings. Following this, the 'G50' command sets a maximum spindle speed of 1000 RPM. This limit is a critical safety feature designed to prevent the spindle from exceeding a safe rotational speed, thus avoiding potential damage to the equipment or workpiece.

Next, the 'G94' command specifies that the feed rate is measured in millimeters per minute. This parameter determines the speed at which the cutting tool advances through the material, impacting both the quality of the finished surface and the efficiency of the machining process.

The 'G50 S1000' command further refines the operational parameters by capping the spindle speed at 1000 RPM, reinforcing the safety limit established earlier. The 'T0101' command selects the cutting tool number 1 and applies cutting tool offset number 1. This command is essential for adjusting the cutting tool's position or dimensions to match the specific requirements of the operation. Following the cutting tool selection and offset adjustment, the 'M06' command instructs the machine to perform a cutting tool change, indicating that cutting tool 1 needs to be loaded and prepared for the machining operation.

Subsequent to the cutting tool change, the command 'G00 X0. Y5. M08' directs the CNC lathe to rapidly move the cutting tool to coordinates X0 Y5. The 'G00' command facilitates rapid positioning without engaging in cutting, allowing for quick repositioning of the cutting tool. Concurrently, the 'M08' command activates the coolant system, which is essential for cooling the cutting tool and workpiece during machining, as well as for reducing friction and improving the quality of the cut.

The 'G01' commands then guide the cutting tool through a series of controlled, linear movements. Initially, the cutting tool moves to X0 Y-28 at a feed rate of 100 millimeters per minute. This movement is part of the facing operation, where material is removed to create a flat surface. Subsequent 'G01' commands direct the cutting tool through specific coordinates, including X-1 Y-29, X-45.5 Y-34, and finalizing with X-52 Y-69. These movements define the toolpath for chamfering operations, which involve creating angled

transitions and contours on the workpiece. The final movement positions the cutting tool at X-53 Y-70, completing the contouring and chamfering processes.

To conclude the machining sequence, the command 'G00 X0. Y5. M09' is used to rapidly retract the cutting tool to the starting coordinates X0 Y5. Additionally, the 'M09' command deactivates the coolant system, ensuring that the cutting tool is safely moved away from the workpiece and that the cooling system is turned off. The program ends with the 'M30' command, which signifies the completion of the machining operation. This command resets the machine to its initial state and prepares it for subsequent tasks or programs, thereby facilitating an orderly transition to the next operation.

In summary, the CNC program is meticulously designed to perform a sequence of machining operations that collectively shape the longer side of the workpiece with high precision. The program initiates with the facing operation, a fundamental process aimed at creating a flat reference surface on the workpiece's front face. This operation involves positioning the cutting tool just above the surface of the workpiece and then advancing it radially inward towards the center. This approach ensures the removal of any irregularities and establishes a smooth, uniform surface, which is critical for the subsequent machining operations. The accuracy of the facing operation is essential for ensuring the workpiece's geometric consistency and provides a clean surface that influences the quality of the subsequent operations.

Subsequently, the turning operation is performed, which is integral to shaping the workpiece into the desired cylindrical form. During this operation, material is removed from the outer surface of the workpiece to achieve the specified diameter along its length. The cutting toolpath is precisely controlled to ensure an even cut, with the cutting tool moving in a diagonal trajectory to effectuate the required diameter reduction. This phase not only transforms the workpiece to its final dimensions but also ensures that the surface finish adheres to the desired tolerances. The turning operation is pivotal in defining the workpiece's final geometry, necessitating precise regulation of feeds and spindle speeds to attain high-quality outcomes.

The final stage of the CNC turning process involves chamfering, which entails the creation of an angled cut at the workpiece's edges. This operation is crucial for eliminating sharp corners and producing a smooth transition between the cylindrical surface and the edges. Chamfering not only enhances the aesthetic characteristics of the workpiece but also addresses practical considerations such as reducing the risk of damage or snagging during handling and assembly. By moving the cutting tool diagonally, the chamfering cut forms a bevel that contributes to both the functional and visual quality of the workpiece. This step is integral to the overall machining process, ensuring that the final product meets design specifications and practical requirements.

Each command in the CNC program is carefully developed to achieve precise control over the cutting tool's movements, thereby ensuring that the workpiece is machined to exact specifications. The program's sequence, comprising facing, turning, and chamfering operations, demonstrates the comprehensive approach required for high-precision manufacturing. This integration of operations within a single program underscores the sophistication of CNC machining and the precision engineering required to produce components that adhere to stringent quality standards. The methodical implementation of

these operations reflects the advanced capabilities of CNC technology and its application in achieving optimal machining results.

4. Conclusion

This paper presents a detailed approach to CNC lathe programming, with a focus on simulating linear interpolation motion. By integrating G-code programming with advanced simulation tools, the research establishes a structured framework for accurately modelling CNC turning processes. It emphasizes the critical role of CNC programs in enhancing machining precision and efficiency, demonstrating the way carefully developed G-codes and M-codes optimize both machine performance and process reliability. The research bridges theoretical principles with practical applications, offering valuable insights into how effective CNC programming improves operational accuracy.

A key focus of the study is the development of precise CNC programs that simulate linear motion paths through the use of G-codes and M-codes, which define CNC machine operations and movements. The incorporation of simulation tools allows for the identification and correction of programming errors before actual machining, streamlining the workflow and ensuring consistency in machining results. This highlights the importance of well-structured programs in achieving reliable and high-quality outcomes in CNC operations.

Moreover, the research paves the way for future exploration of more complex CNC programming techniques, such as circular and helical interpolation, which are especially relevant for multi-axis CNC systems. The insights provided here offer a foundation for future advancements in programming, particularly in the context of optimizing toolpaths and improving machine control in advanced manufacturing environments.

In conclusion, this study makes a significant contribution to CNC programming by illustrating the impact of precise G-code and M-code development on machining precision and operational efficiency. It offers practical guidance for CNC programmers, machinists, and engineers, serving as a resource for improving the reliability and effectiveness of CNC processes. The study allows for continued innovation in CNC programming, particularly in the simulation and development of programs aimed at achieving more precise and efficient machining operations.

References

- [1] *Evans, K.*: (2016). *Programming of CNC Machines*, 4th ed., Industrial Press, South Norwalk, USA
- [2] *Kalpakjian, S. and Schmid, S., R.*: (2009). *Manufacturing Engineering and Technology*, 6th ed., Prentice Hall, Singapore
- [3] *Groover, M. P.*: (2010). *Fundamentals of Modern Manufacturing: Materials, Processes, and Systems*, 4th ed., John Wiley & Sons, Hoboken, USA
- [4] *Lakić, G. G., Kramar, D., and Kopač, J.*: (2014). *Metal Cutting: Theory and Applications*, University of Banja Luka & University of Ljubljana, Banja Luka and Ljubljana
- [5] *Schey J., A.*: (1987). *Introduction to Manufacturing Processes*, 2nd ed., McGraw-Hill, Singapore
- [6] *Radhakrishnan, P., Subramanyan S. and Raju V.*: (2008) *CAD/CAM/CIM*, 3rd ed., New Age International Publishers, New Delhi, India

- [7] Krcheva, V., Chekerovska, M., & Srebrenkoska, S. (2023). Simulation of Toolpaths and Program Verification of a CNC Lathe Machine Tool, XX Jubilee International Scientific Congress - Machines, Technologies, Materials, Vol. 2, No. 26, ISSN 2535-0021, pp. 139-142
- [8] Krcheva, V., Nusev, S., & Janevska, G. (2024). Simulation of Linear Interpolation Motion in CNC Machining, 59th International Scientific Conference on Information, Communication and Energy Systems and Technologies (ICEST), doi: 10.1109/ICEST62335.2024.10639790, pp. 1-4
- [9] ZCC Cutting Tools Europe GmbH.: Main Catalogue, <https://www.zcct-europe.com/en/tools/milling-cutters/>

Violeta Krcheva
Goce Delcev University
Faculty of Mechanical Engineering
Krste Misirkov No. 10-A, Stip
Republic of North Macedonia
E-mail address: violeta.krcheva@ugd.edu.mk

Miša Tomić
University of Nis
Faculty of Mechanical Engineering
Aleksandra Medvedeva No. 14, Niš
Serbia
E-mail address: misa.tomic@masfak.ni.ac.rs