

2024 59th International Scientific Conference on Information, Communication and Energy Systems and Technologies (ICEST) | 979-8-3503-8619-6/24/\$31.00 ©2024 IEEE | DOI: 10.1109/ICEST62335.2024.10699701

2024 59th International Scientific Conference on Information, Communication and Energy Systems and Technologies (ICEST)

Sozopol, Bulgaria, July 1-3, 2024



Technical University of Sofia,
Faculty of Telecommunications,
Bulgaria



University of Niš,
Faculty of Electronic Engineering,
Serbia



University St. Kliment Ohridski,
Faculty of Technical Sciences, Bitola,
North Macedonia

Proceedings of Papers



ISBN: 979-8-3503-8619-6/24/\$31.00 ©2024 IEEE

Technical Co-Sponsors:
IEEE Bulgaria Section
IEEE Serbia and Montenegro Section
IEEE North Macedonia section



ICEST 2024 Conference

59th International Scientific Conference on Information, Communication and Energy Systems and Technologies, Sozopol, Bulgaria, July 1 – 3, 2024

Proceedings of Papers

ICEST 2024 is part of the “Days of Science” at Technical University of Sofia, with the kind collaboration of the Research and Development Sector at TU-Sofia, Bulgaria

ICEST 2024 is IEEE technically co-sponsored conference #62335

https://conferences.ieee.org/conferences_events/conferences/conferencedetails/62335



Technical co-sponsors:

IEEE Bulgaria Section

IEEE Serbia and Montenegro Section

IEEE Republic of North Macedonia Section

Proceedings of Papers will be submitted for posting in IEEE Xplore®

Co-organizers:



Ministry of Education and Science – Bulgaria, Scientific Research Fund

Procedure for support of international scientific forums held in the Republic of Bulgaria

Code of procedure - BG-175467353-2024-03

Name of project proposal - 59th International Scientific Conference on Information, Communication and Energy Systems and Technologies, Sozopol, Bulgaria, July 1 – 3, 2024

Contract number – КΠ06МНФ/12, 25.05.2024

Scientific Research Fund is not responsible for the content of reports submitted to the scientific forum, as well as for the content of advertising and other materials for it.



2024 59th International Scientific Conference on Information, Communication and Energy Systems and Technologies (ICEST)

Bulgaria, Sozopol, July 1 - 3, 2024

Proceedings of Papers

Editors: Assoc. Prof. Dr. Kalin L. Dimitrov
Prof. Dr. Nebojša S. Dončov
Prof. Dr. Mitko Kostov

Technical Support: Assist. Prof. Dr. Tsvetan I. Valkovski
Assoc. Prof. Dr. Ivo R. Draganov

Published by: Institute of Electrical and Electronics Engineers (IEEE)
Faculty of Telecommunications, Technical University of Sofia, Bulgaria

IEEE Catalog Number:
ISBN: 979-8-3503-8619-6/24/\$31.00 ©2024 IEEE

Copyright and Reprint Permission: Abstracting is permitted with credit to the source. Libraries are permitted to photocopy beyond the limit of U.S. copyright law for private use of patrons those articles in this volume that carry a code at the bottom of the first page, provided the per-copy fee indicated in the code is paid through Copyright Clearance Center, 222 Rosewood Drive, Danvers, MA 01923. For reprint or republication permission, email to IEEE Copyrights Manager at pubs-permissions@ieee.org. All rights reserved. Copyright ©2024 by IEEE.



ICEST 2024 Conference

59th International Scientific Conference on Information, Communication and Energy Systems and Technologies, Sozopol, Bulgaria, July 1 – 3, 2024

organized by



**Technical University of Sofia
Faculty of Telecommunications
Bulgaria**



**University of Niš
Faculty of Electronic Engineering
Serbia**



**University "St. Kliment Ohridski", Bitola
Faculty of Technical Sciences
North Macedonia**

Technical co-sponsors:

- **IEEE Bulgarian Section**
- **Serbia and Montenegro IEEE Section**
- **IEEE Republic of North Macedonia Section**

TECHNICAL PROGRAM COMMITTEE

Chair:

Kalin Dimitrov Technical University of Sofia, Bulgaria

Vice-chairs:

Nebojša Dočov University of Niš, Serbia

Mitko Kostov University St.Kliment Ohridski, Bitola, North Macedonia

Honorary Chairs:

Rumen Arnaudov Technical University of Sofia, Bulgaria

Bratislav Milovanović Singidunum University, Niš, Serbia

Cvetko Mitrovski St. Kliment Ohridski University, Bitola, North Macedonia

Local Coordinators:

Agata Manolova Dean of the Faculty of Telecommunications, Technical University of Sofia, Bulgaria

Dragan Mančić Dean of the Faculty of Electronic Engineering, University of Niš, Serbia

Stojance Nusev St. Kliment Ohridski University, Bitola, North Macedonia

Members:

Ilija Iliev Technical University of Sofia, Bulgaria

Biljana Stošić University of Niš, Serbia

Boyanka Nikolova Technical University of Sofia, Bulgaria

Brian Barsky University of California, Berkeley, USA

Chrysostomos Stylios Technological Education Institute of Epiros, Greece

Đani Juričić Jožef Stefan Institute, Slovenia

D.D. Rasolomampionona Warsaw University of Technology, Poland

Dimitar Taskovski Ss. Cyril and Methodius University Skopje, North Macedonia

Dimiter Alexandrov Lakehead University, Canada

Dragan Denić University of Niš, Serbia

Dragan Stojanović University of Niš, Serbia

Dušanka Bošković University of Sarajevo, Bosnia and Herzegovina

Eduard Ivanjko University of Zagreb, Croatia

Evelin Krmac University of Ljubljana, Slovenia

Evelina Pencheva Technical University of Sofia, Bulgaria

Fernando Alvarez University of Extremadura, Spain

Filiz Güneş Yıldiz Technical University, Turkey

Ismail Altas Karadeniz Technical University, Turkey

Ivan Corbev Ss. Cyril and Methodius University Skopje, North Macedonia

J.A.R.P. de Carvalho University Beira Interior, Portugal

Jair Minoro Abe Paulista University, Brazil

Jan Machac Czech Technical University, Prague, Czech Republic

Jugoslav Joković University of Niš, Serbia

Karel Raz University of West Bohemia, Czech Republic

Kazumi Nakamatsu University of Hyogo, Japan

Ljupčo Trpezanovski St. Kliment Ohridski University Bitola, North Macedonia

Mariofanna Milanova University of Arkansas at Little Rock, USA

Metodija Atanasovski	St. Kliment Ohridski University Bitola, North Macedonia
Mikolaj Bartłomiejczyk	Gdańsk University of Technology, Poland
Mikolaj Leszczuk	AGH University of Science and Technology, Poland
Nikola Donato	University of Messina, Italy
Pece Mitrevski	St. Kliment Ohridski University Bitola, North Macedonia
Pero Latkoski	Ss. Cyril and Methodius University Skopje, North Macedonia
Petar Popovski	Aalborg University, Denmark
Peter Planinšič	University of Maribor, Slovenia
Slavko Rupčić	University of Osijek, Croatia
Stanimir Valtchev	New University of Lisbon, Portugal
Stefan Stancescu	Polytechnic University of Bucharest, Romania
Stevo Bozinovski	South Carolina State University, USA
Szilvia Nagy	University of Gyor, Hungary
Urban Burnik	University of Ljubljana, Slovenia
Uwe Siart	Technical University of Munich, Germany
Vincenzo Piuri	University of Milan, Italy
Wojciech Krzysztofik	Wroclaw University of Technology, Poland
Wojtek Bock	University of Ottawa, Canada
Zdenka Babić	University of Banja Luka, Bosnia and Herzegovina
Zoran Jovanović	University of Niš, Serbia
Zoran Stanković	University of Niš, Serbia
Olivera Pronić-Rančić	University of Niš, Serbia
Zlatica Marinković	University of Niš, Serbia
Aleksandra Panajotovic	University of Niš, Serbia
Boban Veselic	University of Niš, Serbia
Nataša Maleš-Ilic	University of Niš, Serbia
Zlatica Marinkovic	University of Niš, Serbia
Blagoja Arapinoski	St. Kliment Ohridski University Bitola, North Macedonia
Gordana Janevska	St. Kliment Ohridski University Bitola, North Macedonia
S. Stavreva	St. Kliment Ohridski University Bitola, North Macedonia
N. Mojsovska	St. Kliment Ohridski University Bitola, North Macedonia
I. Andreevski	St. Kliment Ohridski University Bitola, North Macedonia
Z. Josevski	St. Kliment Ohridski University Bitola, North Macedonia
J. Bunevska	St. Kliment Ohridski University Bitola, North Macedonia
Goran Veljanovski	St. Kliment Ohridski University Bitola, North Macedonia
Pande Popovski	St. Kliment Ohridski University Bitola, North Macedonia

CONFERENCE ORGANIZING COMMITTEE

Chairs:

K. Dimitrov	Technical University of Sofia, Bulgaria
N. Dončov	University of Niš, Serbia
M. Kostov	St. Kliment Ohridski University, Bitola, North Macedonia

Local Coordinators:

A. Manolova	Technical University of Sofia, Bulgaria
D. Mančić	University of Niš, Serbia

S. Nusev St. Kliment Ohridski University, Bitola, North Macedonia

Technical Editor:

T. Valkovski Technical University of Sofia, Bulgaria

I. Draganov Technical University of Sofia, Bulgaria

Secretary:

K. Stoyanova Technical University of Sofia, Bulgaria

Members:

K. Stoyanova Technical University of Sofia, Bulgaria

N. Hristova Technical University of Sofia, Bulgaria

I. Nachev Technical University of Sofia, Bulgaria

M. Stoyanova Technical University of Sofia, Bulgaria

A. Atanasković University of Niš, Serbia

T. Dimitrijević University of Niš, Serbia

J. Joković University of Niš, Serbia

D. Mančić University of Niš, Serbia

N. Maleš-Ilić University of Niš, Serbia

Z. Marinković University of Niš, Serbia

V. Marković University of Niš, Serbia

M. Milijić University of Niš, Serbia

O. Pronić-Rančić University of Niš, Serbia

B. Veselić University of Niš, Serbia

L. Stoimenov University of Niš, Serbia

J. Milošević University of Niš, Serbia

Z. Stanković University of Niš, Serbia

A. Panajotovic **University of Niš, Serbia**

M. Atanasovski St. Kliment Ohridski University, Bitola, North Macedonia

B. Arapinoski St. Kliment Ohridski University, Bitola, North Macedonia

G. Janevska St. Kliment Ohridski University, Bitola, North Macedonia

V. Dancevska St. Kliment Ohridski University, Bitola, North Macedonia

N. Mojsovska St. Kliment Ohridski University, Bitola, North Macedonia

J. Pargovski St. Kliment Ohridski University, Bitola, North Macedonia

M. Spirovski St. Kliment Ohridski University, Bitola, North Macedonia

I. Andreevski St. Kliment Ohridski University, Bitola, North Macedonia

D. Koltovska St. Kliment Ohridski University, Bitola, North Macedonia

S. Stavreva St. Kliment Ohridski University Bitola, North Macedonia

Z. Josevski St. Kliment Ohridski University Bitola, North Macedonia

J. Bunevska St. Kliment Ohridski University Bitola, North Macedonia

G. Veljanovski St. Kliment Ohridski University Bitola, North Macedonia

P. Popovski St. Kliment Ohridski University Bitola, North Macedonia

Address:

ICEST 2024 Conference

Technical University of Sofia

Faculty of Telecommunications

8 Kliment Ohridski Blvd.

1756 Sofia, Bulgaria

phone: +359 2 965 2272

e-mail: icest@tu-sofia.bg

CONFERENCE INTERNET SITE

For further information, please visit the Conference Internet Site: <http://www.icestconf.org>

LIST OF ICEST 2024 REVIEWERS

Technical University of Sofia, Bulgaria

Maria Pavlova
Tihomir Brusev
Roumen Trifonov
Sergei Nedev
Kamelia Nikolova
Georgi Balabanov
Peter Petkov
Boncho Bonev
Rosen Miletiev
Dimitar Arnaudov
Svetlin Antonov
Nikolay Hinov
Vladimir Hristov
Nicole Christoff
Marin Nedelchev
Boris Borisov
Lyubomir Laskov
Yavor Sofronov
Neven Nikolov
Ivo Dochev
Ivaylo Nachev
Gergana Vacheva
Kalin Dimitrov
Tsvetan Valkovski
Serafim Tabakov
Agata Manolova
Rumen Mironov
Marin Marinov
Anna Stoynova
Valentin Hristov
Elena Nikolova
Plamen Stanchev
Kamen Hristov
Maria Nenova
Krasimir Tonchev
Antoni Ivanov
Georgi Stojchev
Ivo Draganov
Julian Velchev
Kiril Kusev

St. Kliment Ohridski University, Bitola, North Macedonia

Mitko Kostov
Nikola Rendevski
Blagoj Ristevski
Ilija Jolevski
Metodija Atanasovski
Gordana Janevska
Aleksandar Markoski
Sevde Stavreva

University of Niš, Serbia

Biljana Stošić
Zoran Stanković
Tijana Dimitrijević
Marija Milijić
Olivera Pronić – Rančić
Nataša Maleš –Ilić
Jugoslav Joković
Nenad Milošević
Aleksandra Panajotović
Stevica Cvetković
Dragan Stojanović
Aleksandar Dimitrijević
Aleksandar Atanasković

AUTHOR INDEX

A

Acevski, Nikolche
Ahmad, Omar Bani
Aleksieva, Pavlina
Anđelković, Marko
Angelov, George
Antonov, Svetlin
Arapinoski, Blagoja
Asenov, Dimitar
Atanasković, Aleksandar
Atanasovski, Metodija
Avramov, Emil
Avramova, Milena

B

Bocevska, Andrijana
Boychev, Iliyan
Bozhinov, Mihail

C

Čabarkapa, Milan
Christoffm, Nicole
Ciric, Dejan
Çolak, Sultan Aldirmaz
Chekurov, Ivan

D

Damyarov, Ilian
Daneva, Marlena Yordanova
Dimitrijević, Tijana
Dimitrov, Kalin
Dimitrova, Kremena
Dimova, Biliana
Djamiykov, Vergil
Dochev, Ivo
Docheva, Lilyana
Doncov, Nebojsa
Donev, Vanyo

Dorđević, Srđan
Đorić, Aleksandra
Đošić, Sandra
Dündar, Abdullah Oktay
DÜNDAR, Özgür

E

Erenoglu, Mehmet Z.

G

Gaidarov, Nikolay
Gajić, Ivana Savić
Galabov, Vasil
Georgiev, Angel
Georgieva, Polya
Godpodinova, Dilyana
Gospodinova, Ekaterina
Gotseva, Nikol
Gotseva, Daniela

H

Hinov, Nikolay
Hristov, Aleksandar
Hristov, Hristo
Hristov, Vladimir

I

Ilić, Zoran
Iliev, Desislav
Iliev, Iliya
Ilieva, Ana
Iontchev, Emil
Ivanov, Ivan
Ivanov, Ivelin

J

Janevska, Gordana
Janković, Marko

Joković, Jugoslav
Jovanović, Milica

K

Kamberov, Konstantin
Karova, Milena
Kireva-Mihova, Denitsa
Kocak, Bekir
Kocer, Hasan Erdinc
KOÇER, Sabri
Kostić, Mirjana
Kostov, Mitko
Krcheva, Violeta
Krstić, Vladica

L

Leordenau, Marius - Plenary report
Linkov, Stivan

M

Madzharov, Nikolay
Males-Ilić, Nataša'
Manev, Stoycho
Manolova, Agata
Marinov, Tsvetan
Miletiev, Rosen
Mirchev, Kalin
Mirković, Milena Stanojlović
Mironov, Rumen
Mitrevski, Pece
MOHAMED, Omar

N

Nachev, Ivaylo
Nedeljkovic, Jelena
Nenova, Maria
Neznakomova, Margarita
Nikolić, Goran
Nikolić, Tatjana
Nikolov, Neven

Nikolova, Elena
Nikolovski, Saso
Nusev, Stojance

P

Pantić, Aleksandar
Paroushev, Deyan
Pavlova, Maria
Pavlova, Yoana
Perić, Nemanja
Pešić, Ksenija
Petkov, Peter Z
Petkova, Diana
Petkova, Radostina
Petreska, Anita
Petreska, Hristina
Petrov, Nikolay
Petrovic, Nenad
Polimenov, Ventsislav
Popov, George
Popova, Antoaneta
Popova, Milena
Popovski, Pande
Poulkov, Vladimir
Pronic-Rancicm, Olivera
Protić, Milan
Puljizević, Maro

R

Ristevski, Blagoj
Rusev, Rostislav
Ruskova, Ivelina

S

Şahman, Mehmet Akif
Saliev, Durhan
Savić, Ivan
Sheiretskym, Kostadin
Simeonov, Zdravka
Sofronov, Yavor

Sotirov, Sotir - Plenary report

Spasova, Gergana

Stanchev, Plamen

Stanković, Zoran

Stojanović, Miloš

Stokić, Ivana

Stoyanov, Aleksandar

Suljović, Suad

Svirčev, Zorica

T

Todorov, Georgi

Tokan, Nurhan Türker

Trajkovska, Aneta

Trushev, Ivan

Tsonev, Veselin

Tsoneva, Mina

Tzaneva, Boriana

Tzanova, Anelia

V

Vacheva, Gergana

Valkanov, Vladimir

Valkovski, Tsvetan

Vasileva, Evgeniya

Veljanovski, Goran

Vlahov, Atanas

Vujović, Vuk

W

Wrekat, Alaa

Y

Yasar, Ali

Z

Zagorski, Mihail

Zhelyazkov, Yuri

Zlatev, Blagovest

TABLE OF CONTENTS

Sustainable Future Communication Networks in the Context of a Green Economy

Regular papers:

Radostina Petkova, Deep Point Cloud Compression of Indoor Environment Scenes

Nikol Gotseva, Atanas Vlahov, Vladimir Poulkov, Agata Manolova, ML-driven Prediction of QoS in C-V2X Scenarios

Polya Georgieva, Atanas Vlahov, Vladimir Poulkov, Agata Manolova, A Machine Learning Approach for Network Slice Selection

Radio Communications, Microwaves, Antennas

Regular papers:

Hasan Erdinc Kocer, Bekir Kocak, LoRa Based Stray Animals Tracking System

Hristo Hristov, Kalin Dimitrov, Investigating the possibilities of using radiometry in the infrared spectrum for drone monitoring of cattle within free-range farming in the flat and semi-mountainous part of Southeastern Balkan peninsula

Mehmet Z. Erenoglu, Sultan Aldirmaz Çolak, Nurhan Türker Tokan, Detection of Human Breathing Using Signal Processing Techniques Under Debris

Ivelin Ivanov, Stivan Linkov, Peter Petkov, Ground Decoupled J-pole Antenna

Pavlina Aleksieva, Peter Z Petkov, Ivaylo Nachev, Precision improved model for NenuFAR and LWA, using the Finite Element Method

Radio Communications, Microwaves, Antennas

Posters:

Ivana Savić Gajić, Ivan Savić, Mirjana Kostić, Zorica Svirčev, Microwave-Assisted Extraction of Fucoidan from the Brown Seaweed (*Laminaria digitata*) Biomass

Nemanja Perić, Ksenija Pešić, Nebojša Dončov, Zoran Stanković, Olivera Pronić Rančić, MLP-PNN Model of Dual-Band Microstrip Patch Antenna for GNSS Receivers

Zoran Stanković, Olivera Pronić-Rančić, Nebojša Dončov, Direction of Arrival Estimation in Smart Textile Wearable Antenna Arrays using Deep Neural Networks

Tijana Dimitrijević, Jugoslav Joković, Aleksandar Atanasković, Nebojša Dončov, Analysis of a Cylindrical Enclosure Effectiveness by TLM Method

Ksenija Pesic, Zoran Stankovic, Nebojsa Doncov, Modeling the input impedance of a Coplanar Inverted F Antenna using ANN

Ivaylo Nachev, Ilia Iliev, Ana Ilieva, Tsvetan Valkovski, Model of Scanning Antenna Array with UAV Navigation and OATR Monitoring Applications

Diana Petkova, EBG Structure Integrated in Patch Antenna Element Plane for Bandwidth Enhancement

Aleksandra Đorić, Aleksandar Atanasković, Nataša Maleš Ilić, Milena Stanojlović Mirković, Dual-Band PA Linearization by Combined Techniques – DPD Compensation Technique and Digital Second-Order Linearization Technique

Telecommunication Systems and Technology

Regular papers:

Omar Bani Ahmad, Alaa Wrekat, Performance valuation of Spatial Diversity Techniques in Transdermal Optical Communications with Pointing Errors

Telecommunication Systems and Technology

Posters:

Tsvetan Marinov, Performance Comparison and Analysis of AODV and MTP Routing Protocols in VANET for Urban Scenario

Digital Image Processing

Regular papers:

Nikolay Gaidarov, Nicole Christoff, Deep Learning Classification Algorithm for Denoising Video Sequences

Rumen Mironov, Local Adaptive 2D Recursive Sliding Mean Filtration of Halftone Images

Digital Image Processing

Posters:

Milan Protić, Zoran Ilić, Vladica Krstić, Miloš Stojanović, Utilizing Unmanned Aerial Vehicles for Detecting Heat Losses in District Heating Networks

Computer Systems and Internet Technologies

Regular papers:

Kalin Dimitrov, Emil Avramov, Milena Avramova, Dimitar Asenov, Temperature changes of selected surfaces of the throwing hand of female handball players during training, assessed by thermal imaging of skin temperature

Deyan Paroushev, Standardizing Financial Data Exchange: The Role and Impact of the Financial Product Markup Language (FpML)

Saso Nikolovski, Pece Mitrevski, Anita Petreska, Performance analysis of cloud service-based data protection systems

Aleksandar Hristov, Simulation of Cookie Poisoning network attacks

Computer Systems and Internet Technologies

Posters:

Nenad Petrovic, Suad Suljović, Srđan Đorđević, Vuk Vujović, Ivana Stokić, RAG-Enriched Approach to Network Standardization: MGF Based Calculation of Average Bit Error Probability in Nakagami-m Fading Environment with Selection Diversity Receiver Case Study

Vladimir Hristov, Electric DC Drive System Allow Two Direction Energy Exchange

Neven Nikolov, Daniela Gotseva, Make a prototype of IoT connected diagnostic tool using Esp32 and MQTT for reading data from car CAN bus OBD2

Gergana Spasova, Milena Karova, Iliyan Boychev, Communication Protocol for Liquid Dispensing Vending Machines

Ekaterina Gospodinova, Urban Information Infrastructure Modal Interface Construction Algorithm

Informatics and Computer Science

Regular papers:

Sabri KOÇER, Omar MOHAMED, Özgür DÜNDAR, Disease Detection in Abdominal CT Images Using the YOLOv5 Algorithm: A Deep Learning Approach

Ali YASAR, Identification of Dry Bean Seeds Using PSO Feature Selection Technique

Mehmet Akif Şahman, Abdullah Oktay Dündar, Comparative Performance Analysis of Meta-Heuristic Algorithms in Distributed Job Shop Scheduling

Aneta Trajkovska, Andrijana Bocevska, Blagoj Ristevski, 3D Scientific Visualization using Mayavi

Ventsislav Polimenov, Krassimira Ivanova, Mihaela Tsvetkova, Elena Anastasova, and Katya Dimitrova, Calculating Leaf Area Index Using Neural Network and WorldView 3 Multispectral Imagery

Angel Georgiev, Vladimir Valkanov, Role-Based Access Control Technique with Trino for restriction in Hive-based Data Warehouse

Informatics and Computer Science

Posters:

George Popov, Antoaneta Popova, Milena Popova, Application of System Diversity to Processing Unstable Data

Vanyo Donev, An Algorithm for Sorting an Array with Non-Repeating Numbers by Direct Positioning

Zdravka Simeonov, Analyzing the Impact of Workforce Distribution on Regional Economy Using GIS: Spatial Analysis

Electronics

Posters:

Elena Nikolova, New trends in the development of laser endoscopic surgery

Jelena Nedeljković, Sandra Došić, Milica Jovanović, Utilizing Implications in Error Detection: Methods Overview

Plamen Stanchev, Gergana Vacheva, Nikolay Hinov, Analysis of Electrical Energy Consumption of Industrial Enterprises Based on IoT

Rostislav Rusev, Ivaylo Nachev, Stoycho Manev, Radial-type Piezoelectric Transformer with Rochelle Salt Layers

Rostislav Rusev, Ivelina Ruskova, Boriana Tzaneva, George Angelov, Piezo-photodiode from Rochelle Salt and Methyl Red Layers

Gergana Vacheva, Plamen Stanchev, Nikolay Hinov, Harmonic Analysis of ZETA DC-DC Converter

Jelena Nedeljković, Goran Nikolić, Marko Anđelković, Tatjana Nikolić, Software implemented implication-based online error detection

Georgi Todorov, Konstantin Kamberov, Blagovest Zlatev, Approach for assessment of electronics control unit for airborne application through virtual prototyping

Georgi Todorov, Konstantin Kamberov, Yavor Sofronov, Analysis and requirements definition of end effector design for a semiconductor wafer handling

Energy Systems and Efficiency

Regular papers:

Pande Popovski, Nikolche Acevski, Mitko Kostov, Grounding System Analysis Using CAD Assisted Software

Gergana Vacheva, Plamen Stanchev, Nikolay Hinov, Evaluation of Energy Efficiency in Smart Grids

Maria Pavlova, Ivan Trushev, Anelia Tzanova, Modeling the Spread of Fire and Hazards in the Atmosphere under the Impact of the Wind

Biliana Dimova, Veselin Tsonev, Maria Nenova, On the stress calculation of the uniform strength rotating disks of variable thicknesses

Energy Systems and Efficiency

Posters:

Hristina Petreska, Pande Popovski, Goran Veljanovski, Metodija Atanasovski, Blagoja Arapinoski, Comparison of Dynamic Behavior of Dispersed Generation Based on (A)Synchronous Generator and Inverter

Desislav Iliev, Nikolay Madzharov, Model of a Wireless Power Transfer System with an Extended Air Gap

Evgeniya Vasileva, Optimizing power losses in electricity transmission and distribution

Dilyana Gosdpodinova, Margarita Neznakomova, Express Evaluation of the Thermal Insulation Properties of Bulk Non-Woven Textile

Vladimir Hristov, Ivan Chekurov, A Concept For Smart Warehouses Management For Cow Faeces

Control Systems

Regular papers:

Violeta Krcheva, Stojance Nusev, Gordana Janevska, Mitko Kostov, Simulation of Linear Interpolation Motion in CNC Machining

Control Systems

Posters:

Kalin Mirchev, Denitsa Kireva, Mihail Bozhinov, Measurement of Lateral Track Resistance on a Single Railway Sleeper Based on the Existing Practices

Measurement Science and Technology

Regular papers:

Dejan Ciric, Maro Puljizević, Aleksandar Pantić, Marko Janković, Effects of Energy Decay Curve Deviation on Absorption Coefficient Calculations

Vergil Djamiykov, Vasil Galabov, Calibration methods for high contrast automotive clusters

Mihail Zagorski, Ivan Ivanov, Blagovest Zlatev, 3D Scanning for Assessment of Large-scale Industrial Infrastructure

Rosen Miletiev, Emil Iontchev, Ilian Damyanov, Precise course and relative object position calculation based on RTK technology

Remote Ecological Monitoring

Posters:

Aleksandar Stoyanov, Integration of Remote Ecological Monitoring Technologies in Sustainable Business Practices for 3 Industries supply chains

Tsvetan Valkovski, Durhan Saliev, Iliyan Damyanov, Monitoring and assessment of pasture quality through ground-based thermographic imaging in the different seasons and years

Tsvetan Valkovski, Ivaylo Nachev, Analysis and application of the OATR methods in the smart cities

Tsvetan Valkovski, Durhan Saliev, Iliyan Damyanov, Kalin Dimitrov, A comparison of ground-based and aerial thermographic imaging of grasslands

Engineering Education

Regular papers:

Yoana Pavlova, AI и Ethical Principles for Sustainable Learning Development

Engineering Education

Posters:

Aleksandar Atanasković, Tijana Dimitrijević, Nataša Maleš Ilić, Milan Čabarkapa, Empowering IoT education utilizing free online Arduino simulators

Marlena Yordanova Daneva, Optimizing the quality of education of students studying engineering and pedagogy

Kostadin Sheiretsky, Svetlin Antonov, Extremal Properties of a Functional Dependent on a Small Parameter

Kostadin Sheiretsky, Svetlin Antonov, Evaluation of the Asymptotic Expansion of a Numerical Function

Gergana Vacheva, Plamen Stanchev, Nikolay Hinov, LTSpice Based Stability Analysis of Buck DC-DC Converter

Gergana Vacheva, Plamen Stanchev, Nikolay Hinov, Hardware System for Education of Power Electronics based on IoT

Ivo Dochev, Lilyana Docheva, Stoycho Manev, Study of communication system with PSK modulation

Nikolay Petrov, Mina Tsoneva, Kremena Dimitrova, Yuri Zhelyazkov, Reliability-Qualitative Research of Risk Technical Systems

Simulation of Linear Interpolation Motion in CNC Machining

Violeta Krcheva¹, Stojance Nusev¹ and Gordana Janevska¹

Abstract – This paper delves into the intricate realm of CNC machining by focusing on the simulation of linear interpolation motion. Through meticulous analysis and simulation, it offers a comprehensive understanding of the dynamics underlying linear interpolation in CNC machining processes. The incorporation of G-codes alongside a visualisation approach enhances both clarity and applicability, thereby facilitating innovation and optimisation in the field of CNC machining.

Keywords – Turning, Milling, Drilling, G-codes, Visualisation.

I. INTRODUCTION

The simulation of the machining processes constitutes a methodological approach in simulation-driven design, facilitating the predictability of behaviour, performance, and outcomes across various machining processes, particularly in CNC machining. Distinguished by its reliance on computer-based product modelling and simulation, this methodology significantly enhances the quality and efficiency of machining processes [1].

Machining processes represent a fundamental aspect of the machining industry, pivotal for material removal from initial workparts to attain the desired final products. Classified as material removal processes, they encompass machining operations to shape metals into functional components. Turning, milling, and drilling stand out as the three most common machining operations, characterised by the precise separation of the material by the cutting tool, chip formations, and a new surface generation [2].

Machining processes are interconnected with the availability of compatible machine tools for their realisation. Over recent years, computer numerically controlled (CNC) machine tools have been prevalent in the manufacturing industry due to their enhanced reliability in comparison to traditional machine tools. Essential to the operation of CNC machine tools is the formulation of a precise sequence of instructions, commonly referred to as CNC programming [3].

CNC programming is a specialised field concerned with creating instructions to control CNC machine tools. Central to this field are G-codes, which exert control over the machine's tool moving parts, commonly associated with the functioning of an interpolator. This component, as a fundamental element of CNC systems, transforms the geometric toolpath into

vectors of tool positions (Fig. 1a), enabling visualisation of the machine's motion and accurate orientation of its components in three-dimensional space (Fig. 1b) [4].

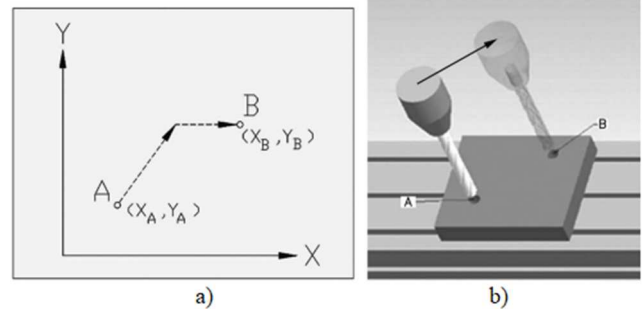

Fig. 1. a) Toolpath, b) Position of the cutting tool [5]

The toolpath closely aligns with the design specifications of the workpart, utilising information primarily from Computer-Aided Design (CAD). Complementary to CAD, Computer-Aided Manufacturing (CAM) software synchronises product design and machining processes, particularly in the realm of CNC machining. In correlation with CAD systems, CNC simulators represent advanced software solutions that imitate the behaviour and resultant outcomes of machining processes performed on sophisticated CNC machine tools [6].

The primary objective of this paper is to provide a comprehensive exposition of the machining process through CAD, alongside the creation of G-code-based programmes and subsequent simulation. Furthermore, the paper meticulously delineates the simulation procedure, a crucial aspect for verifying the efficacy and accuracy of the proposed machining operations. It aims to offer a thorough insight into linear interpolation motion within CNC machining, elucidating its multifaceted implications for industrial applications.

The simulation method contributes to a clear visualisation of the motion in CNC machining, including the understanding of the machining process performed on modern CNC machine tools and their functionalities, as extensively reviewed in relevant literature (e.g., [1]–[9]). Structurally, the paper comprises four sections: an introduction, a detailed research explanation, a discussion of the obtained results, and concluding remarks with potential applications.

II. RESEARCH

This research provides a comprehensive analysis of the design, programming, and simulation necessary for achieving linear interpolation motion in the CNC machining process of a clutch hub, with a particular focus on its outer contours.

To facilitate this analysis, precise 2D drawings are created using CAD systems, specifically AutoCAD software. These

¹Violeta Krcheva, Stojance Nusev and Gordana Janevska are with University St. Kliment Ohridski - Bitola, Faculty of Technical Sciences, Makedonska falanga 37, 7000 Bitola, Republic of North Macedonia, E-mail: {violeta.krcheva, stojance.nusev, gordana.janevska}@uklo.edu.mk

drawings accurately depict the machining operations involved, illustrating the progression from the initial forged clutch hub (Fig. 2a) to the final machined product (Fig. 2b).

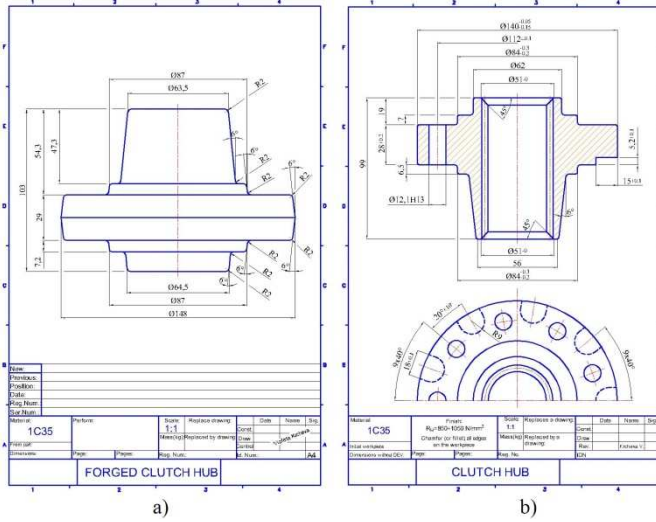

Fig. 2. a) Forged clutch hub, b) Clutch hub

The machining process comprises four machining operations.

The first operation is turning (Fig. 3), which refers to the shorter side of the workpart. The designated cutting tool for this operation is the PCLNR3232P19 external tool holder (Fig. 4a).

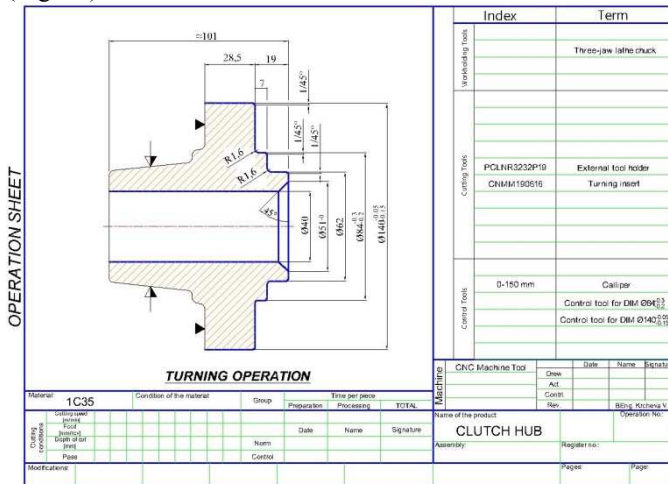

Fig. 3. First machining operation

This tool holder is joined by the CNMM190616 turning insert (Fig. 4a), both manufactured by ZCC-CT.



Fig. 4. Cutting tools

The second operation is turning (Fig. 5), which refers to the longer side of the workpart. The cutting tool designated for this operation remains consistent with the previous one.

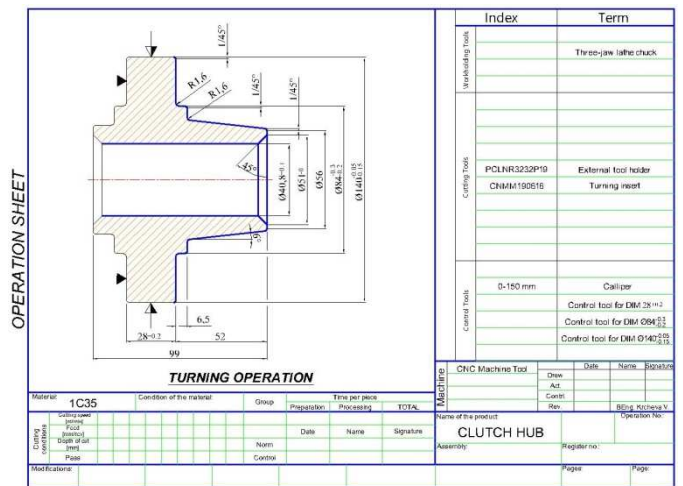

Fig. 5. Second machining operation

The third operation is milling (Fig. 6). The designated cutting tool for this operation is the S602R302GM-1800 end mill (Fig. 4b), produced by ZCC-CT.

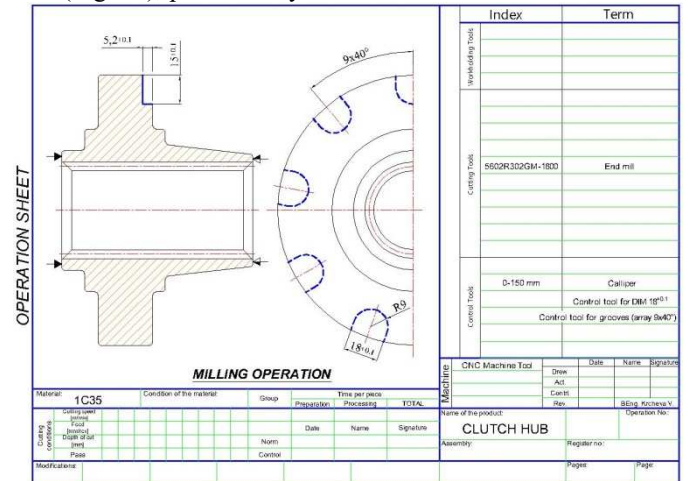

Fig. 6. Third machining operation

The fourth operation is drilling (Fig. 7). The designated cutting tool for this operation is the 1534SU03-1210 drill (Fig. 4c), produced by ZCC-CT.

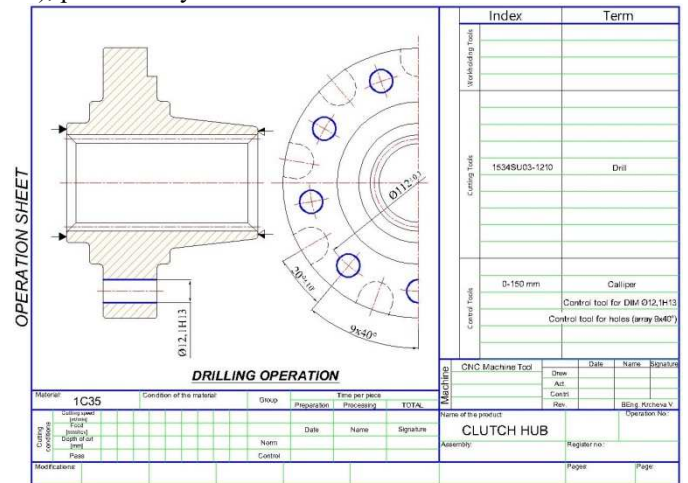

Fig. 7. Fourth machining operation

For each machining operation, a CNC programme is created (and is presented as a figure for space conservation and clarity). The programme of instructions for the first machining operation is depicted in Fig. 8.

```

%
O0001          N110 G01 X-1 Y31
N10 G21       N120 G01 X-12 Y31
N20 G17       N130 G01 X-12 Y41
N30 G40       N140 G01 X-13 Y42
N40 G90       N150 G01 X-19 Y42
N50 G94       N160 G01 X-19 Y69
N60 T0101     N170 G01 X-20 Y70
N70 M06       N180 G01 X-47.5 Y70
N80 G00 X0 Y0 N190 G00 Z5
N90 G01 Z-5 F0.2 N200 M30
N100 G01 X0 Y30 %

```

Fig. 8. First programme of instructions

The programme of instructions for the second machining operation is depicted in Fig. 9.

```

%
O0001
N10 G21 G17 G40 G50 G94 N90 G01 X-45.5 Y-41.
N20 G50 S1000           N100 G01 X-46.5 Y-42.
N30 T0101              N110 G01 X-52. Y-42.
N40 M06                N120 G01 X-52. Y-69.
N50 G00 X0. Y5. M08    N130 G01 X-53. Y-70.
N60 G01 X0. Y-28. F100. N140 G00 X0. Y5. M09
N70 G01 X-1. Y-29.     N150 M30
N80 G01 X-45.5 Y-34.   %

```

Fig. 9. Second programme of instructions

The programme of instructions for the third machining operation is depicted in Fig. 10.

```

%
O0001          G01 X35.4 Y42.1      G01 X-60.6 Y-35
T1 M06         G01 X45 Y53.6       G01 X-23.9 Y-65.8
G17           G01 X0 Y70           G01 X-18.8 Y-51.7
G21           G01 X0 Y55           G01 X-23.9 Y-65.8
G90           G01 X0 Y70           G01 X23.9 Y-65.8
G40           G01 X-45 Y53.6       G01 X18.8 Y-51.7
G49           G01 X-35.4 Y42.1     G01 X23.9 Y-65.8
G80           G01 X-45 Y53.6       G01 X60.6 Y-35
M03           G01 X-68.9 Y12.2     G01 X47.6 Y-27.5
G00 X68.9 Y12.2 G01 X-54.2 Y9.6   G01 X60.6 Y-35
G01 X54.2 Y9.6 G01 X-68.9 Y12.2   M05
G01 X68.9 Y12.2 G01 X-60.6 Y-35   M30
G01 X45 Y53.6 G01 X-47.6 Y-27.5   %

```

Fig. 10. Third programme of instructions

The programme of instructions for the fourth machining operation is depicted in Fig. 11.

```

%
O0001
G17 G20 G40 G49 G80 G90 X-36 Y-42.9
T01 M06 X0 Y-56
M03 X36 Y-42.9
G81 R0.1 Z-28 F0.2 X55.2 Y-9.7
X19.2 Y52.6 G80
X-19.2 Y52.6 M05
X-48.5 Y28 M30
X-55.1 Y-9.7 %

```

Fig. 11. Fourth programme of instructions

These programmes of instructions are subsequently utilised in simulation software to predict and visualise the cutting tool's movement in practical conditions during the implementation of machining operations.

III. RESULTS AND DISCUSSION

The following figures demonstrate the simulation of each toolpath aligned with the programmes of instructions composed of G-codes. These codes, also known as movement instructions, have defined the trajectory, direction, and precise positional movement of the cutting tool within a predetermined coordinate system. Additionally, incorporated M-codes in this programming language have controlled crucial machine tool operations such as main spindle speed, cutting tool feed rate, tool changes, coolant deployment, etc.

In the CIMCO Edit 2024 software programme, the toolpath for each machining operation is displayed, visually representing the sequential straight-line movements between coordinates defined in each programme. This visualisation offers a clear insight into the machining process, illustrating how these movements collectively shape the toolpath and interpolation motion in the CNC operations being analysed.

The simulation of programmes is intricately linked to the Cartesian coordinate system, a fundamental framework wherein every point on the workpiece corresponds to distinct X, Y, and Z coordinates. These coordinates define the programmed cutting tool's point in relation to the workpart and are derived from the diameters, lengths, and other dimensions specified in AutoCAD drawings for each machining operation.

The precise, straight-line movements achieved between meticulously defined coordinates within the simulation confirm the accuracy of the programmes and exemplify the foundational principle of linear motion in CNC machining. This motion predominantly occurs along one or more linear axes, typically X, Y, and Z, within three-dimensional space. It frequently necessitates interpolation, which involves the calculation and generation of intermediate points along the desired path, ensuring smooth and continuous movement.

The simulation of the first machining operation, as illustrated in Fig. 12, provides confirmation of its successful completion through the utilisation of linear interpolation motion. This motion entails the precise movement of the cutting tool along both the horizontal and vertical axes within the machining environment.

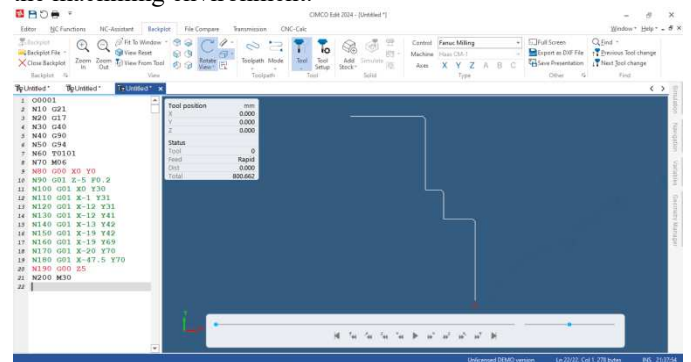

Fig. 12. Simulation of the first machining operation

During the realisation of the second machining operation, as depicted in Fig. 13, the cutting tool performs linear interpolation motions as it traverses along both axes. This process entails the precise calculation and generation of intermediate points along the desired path, facilitating smooth and continuous movement of the cutting tool.

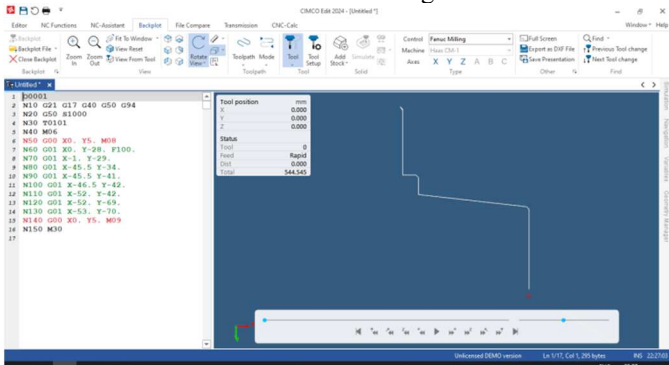

Fig. 13. Simulation of the second machining operation

The successful completion of the third machining operation, as illustrated in Fig. 14, is achieved through the implementation of linear interpolation motions along both the horizontal and vertical axes. Through precise calculation and control, the cutting tool traverses the workpart in a continuous motion, ensuring the accuracy and efficiency of the machining process.

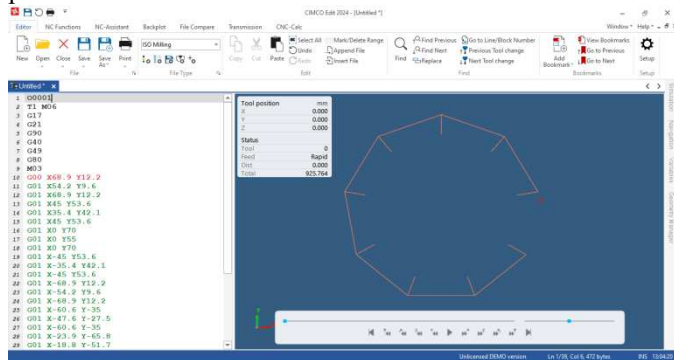

Fig. 14. Simulation of the third machining operation

The fourth machining operation is finalised with precise linear interpolation motion of the cutting tool along the horizontal and vertical axes, as depicted in Fig. 15. This motion ensures accurate machining of the workpart by directing the tool along predefined paths in the horizontal and vertical directions.

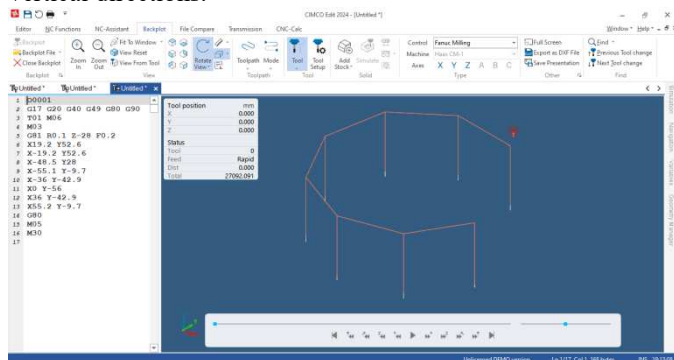

Fig. 15. Simulation of the fourth machining operation

IV. CONCLUSION

The simulation of the machining process is accomplished by a clear visualisation of the four machining operations, all involving linear interpolation motion.

The linear interpolation motion in CNC machining is crucial for achieving precision and accuracy in the production of final parts. By controlling the movement of the cutting tool along linear axes, CNC machines can machine components with tight tolerances and complex geometries, meeting the exact specifications of the design.

The linear interpolation motion in CNC machining is also fundamental to the automation capabilities of CNC machine tools. Through programmed instructions, the CNC controller controls the linear movement of the cutting tool, allowing for automated and repeatable machining processes without the need for manual intervention.

In conclusion, this study significantly advances the collective comprehension of linear interpolation motion within the realm of CNC machining. By prioritising practical applications, it emphasises the immediate relevance of simulation-driven methodologies in the manufacturing industry. Moreover, it facilitates optimisation of machining processes by rapidly examining manufacturing strategies without disturbance or waste, offering solutions for precision engineering, and enhancing efficiency and accuracy through sophisticated simulation methods.

REFERENCES

- [1] Y. A. Hoesen, M. Furqon, N. Novrinaldi, U. Hanifah and N. A. Rofik, "A CNC Turning Process Simulation for a Polygonal Shaft Using CAM ESPRIT Software", *Mechanical Engineering, Science and Technology International Conference*, vol. 63, no. 20, doi:10.3390/engproc2024063020, 2024.
- [2] M. P. Groover, *Fundamentals of Modern Manufacturing: Materials, Processes, and Systems*, 4th ed., Hoboken, John Wiley & Sons, 2010.
- [3] S. Suh, S. Kang, D. Chung, I. Stroud, *Theory and Design of CNC Systems*, London, Springer-Verlag, 2008.
- [4] P. Petráček, P. Fojtu, T. Kozlok and M. Sulitka, "Effect of CNC Interpolator Parameter Settings on Toolpath Precision and Quality in Corner Neighborhoods". *Applied Sciences*. vol. 12, no. 19, doi:10.3390/app12199496, 2022.
- [5] D. E. Kandray, *Programmable Automation Technologies: An Introduction to CNC, Robotics and PLCs*, New York, Industrial Press, 2010.
- [6] P. Radhakrishnan, S. Subramanyan and V. Raju, *CAD/CAM/CIM*, 3rd ed., New Delhi, New Age International Publishers, 2008.
- [7] E. Lo Valvo, R. Licari and A. Adornetto, "CNC Milling Machine Simulation in Engineering Education" *International Journal of Online Engineering (iJOE)*, vol. 8, no. 2, doi 10.3991/ijoe.v8i2.2047, 2012.
- [8] S. Tabaković, S. Zivanovic, Z. Dimic and M. Zeljković, "Programming of 3-Axis Hybrid Kinematics CNC Machine for Rapid Prototyping Using Subtractive and Additive Processes", *Journal of Mechatronics, Automation and Identification Technology*, vol. 6, no. 4, pp. 16-21, 2021.
- [9] K. Evans, *Programming of CNC Machines*, 4th ed., South Norwalk, Industrial Press, 2016.