

**GOCE DELCEV UNIVERSITY, STIP, NORTH MACEDONIA
FACULTY OF ELECTRICAL ENGINEERING**

ETIMA 2023

SECOND INTERNATIONAL CONFERENCE

27-29 SEPTEMBER, 2023



**TECHNICAL SCIENCES APPLIED IN ECONOMY,
EDUCATION AND INDUSTRY**



УНИВЕРЗИТЕТ
ГОЦЕ ДЕЛЧЕВ

ЕЛЕКТРОТЕХНИЧКИ
ФАКУЛТЕТ



ЕЛЕКТРОТЕХНИЧКИ ФАКУЛТЕТ,
УНИВЕРЗИТЕТ „ГОЦЕ ДЕЛЧЕВ”, ШТИП, СЕВЕРНА
МАКЕДОНИЈА

FACULTY OF ELECTRICAL ENGINEERING,
GOCE DELCEV UNIVERSITY, STIP, NORTH MACEDONIA

ВТОРА МЕЃУНАРОДНА КОНФЕРЕНЦИЈА
SECOND INTERNATIONAL CONFERENCE

ЕТИМА / ETIMA 2023

ЗБОРНИК НА ТРУДОВИ
CONFERENCE PROCEEDINGS

27-29 септември 2023 | 27-29 September 2023

ISBN: 978-608-277-040-6

DOI: <https://www.doi.org/10.46763/ETIMA2321>



Главен и одговорен уредник / Editor in Chief

проф. д-р Сашо Гелев
Prof.d-r Saso Gelev

Јазично уредување / Language Editor

Весна Ристова / Vesna Ristova

Техничко уредување / Technical Editing

Дарко Богатинов / Darko Bogatinov

Издавач / Publisher

Електротехнички факултет, Универзитет „Гоце Делчев“, Штип, Северна
Македонија
Faculty of Electrical Engineering, Goce Delcev University, Stip, North Macedonia

Адреса на организационен комитет / Address of the organising committee

Универзитет „Гоце Делчев“, Штип, Северна Македонија
Goce Delcev University, Stip, North Macedonia

Електротехнички факултет / Faculty of Electrical Engineering

Адреса: Крсте Мисирков, 10 А 2000, Штип/ Address: Krste Misirkov, 10A, 2000 Stip

E-mail: conf.etf@ugd.edu.mk

CIP - Каталогизација во публикација Национална и универзитетска библиотека
"Св. Климент Охридски", Скопје

62-049.8(062)

004-049.8(062)

МЕЃУНАРОДНА конференција ЕТИМА (2 ; 2023)

Зборник на трудови [Електронски извор] / Втора меѓународна конференција
ЕТИМА 2023, 27-29 септември 2023 = Conference proceedings / Second
international conference, 27-29 September 2023 ; главен и одговорен уредник
Сашо Гелев]. - Штип : Универзитет "Гоце Делчев", Електротехнички факултет ;
Stip : "Goce Delcev" University, Faculty of Electrical engineering, 2024

Начин на пристапување (URL): <https://www.doi.org/10.46763/ETIMA2321>. -

Текст во PDF формат, содржи 200 стр.илустр. - Наслов преземен од екранот. -

Опис на изворот на ден 25.03.2024. - Трудови на мак. и англ.

јазик. - Библиографија кон трудовите. - Содржи и: Appendix

ISBN 978-608-277-040-6

а) Електротехника -- Примена -- Собири б) Машинство -- Примена -- Собири
в) Автоматика -- Примена -- Собири г) Инфоматика -- Примена -- Собири

COBISS.MK-ID 63335173



Втора меѓународна конференција ЕТИМА
27-29 септември 2023
Second International Conference ETIMA
27-29 September 2023

**ОРГАНИЗАЦИОНЕН ОДБОР
ORGANIZING COMMITTEE**

Василија Шарац / Vasilija Sarac

Електротехнички факултет,
Универзитет „Гоце Делчев“, Штип, Северна Македонија
Faculty of Electrical Engineering,
Goce Delcev University, Stip, North Macedonia

Сашо Гелев / Saso Gelev

Електротехнички факултет,
Универзитет „Гоце Делчев“, Штип, Северна Македонија
Faculty of Electrical Engineering,
Goce Delcev University, Stip, North Macedonia

Тодор Чекеровски / Todor Cekеровски

Електротехнички факултет,
Универзитет „Гоце Делчев“, Штип, Северна Македонија
Faculty of Electrical Engineering,
Goce Delcev University, Stip, North Macedonia

Маја Кукушева Панева / Maja Kukuseva Paneva

Електротехнички факултет,
Универзитет „Гоце Делчев“, Штип, Северна Македонија
Faculty of Electrical Engineering,
Goce Delcev University, Stip, North Macedonia

Билјана Читкушева Димитровска / Biljana Citkuseva Dimitrovska

Електротехнички факултет,
Универзитет „Гоце Делчев“, Штип, Северна Македонија
Faculty of Electrical Engineering,
Goce Delcev University, Stip, North Macedonia

Дарко Богатинов / Darko Bogatinov

Електротехнички факултет,
Универзитет „Гоце Делчев“, Штип, Северна Македонија
Faculty of Electrical Engineering,
Goce Delcev University, Stip, North Macedonia



Втора меѓународна конференција ЕТИМА
27-29 септември 2023
Second International Conference ETIMA
27-29 September 2023

**ПРОГРАМСКИ И НАУЧЕН ОДБОР
SCIENTIFIC COMMITTEE**

Со Ногучи / So Noguchi

Висока школа за информатички науки и технологии
Универзитет Хокаидо, Јапонија
Graduate School of Information Science and Technology
Hokkaido University, Japan

Диониз Гашпаровски / Dionýz Gašparovský

Факултет за електротехника и информациони технологии,
Словачки Технички Универзитет во Братислава, Словачка
Faculty of Electrical Engineering and Information Technology
Slovak Technical University in Bratislava, Slovakia

Антон Белан / Anton Belán

Факултет за електротехника и информациони технологии
Словачки Технички Универзитет во Братислава, Словачка
Faculty of Electrical Engineering and Information Technology
Slovak Technical University in Bratislava, Slovakia

Георги Иванов Георгиев / Georgi Ivanov Georgiev

Технички Универзитет во Габрово, Бугарија
Technical University in Gabrovo, Bulgaria

Ивелина Стефанова Балабанова / Ivelina Stefanova Balabanova

Технички Универзитет во Габрово, Бугарија
Technical University in Gabrovo, Bulgaria

Бојан Димитров Карапeneв / Boyan Dimitrov Karapenev

Технички Универзитет во Габрово, Бугарија
Technical University in Gabrovo, Bulgaria

Сашо Гелев / Saso Gelev

Електротехнички факултет,
Универзитет „Гоце Делчев“, Штип, Северна Македонија
Faculty of Electrical Engineering,
Goce Delcev University, Stip, North Macedonia

Влатко Чингоски / Vlatko Cingoski

Електротехнички факултет,
Универзитет „Гоце Делчев“, Штип, Северна Македонија
Faculty of Electrical Engineering,
Goce Delcev University, Stip, North Macedonia

Божо Крстајиќ / Bozo Krstajic
Електротехнички факултет
Универзитет во Црна Гора, Црна Гора
Faculty of Electrical Engineering,
University in Montenegro, Montenegro

Милован Радуловиќ / Milovan Radulovic
Електротехнички факултет
Универзитет во Црна Гора, Црна Гора
Faculty of Electrical Engineering,
University in Montenegro, Montenegro

Гоце Стефанов / Goce Stefanov
Електротехнички факултет,
Универзитет „Гоце Делчев“, Штип, Северна Македонија
Faculty of Electrical Engineering,
Goce Delcev University, Stip, North Macedonia

Мирјана Периќ / Mirjana Peric
Електронски факултет
Универзитет во Ниш, Србија
Faculty of Electronic Engineering,
University of Nis, Serbia

Ана Вучковиќ / Ana Vuckovic
Електронски факултет
Универзитет во Ниш, Србија
Faculty of Electronic Engineering,
University of Nis, Serbia

Тодор Чекеровски / Todor Cekerovski
Електротехнички факултет,
Универзитет „Гоце Делчев“, Штип, Северна Македонија
Faculty of Electrical Engineering,
Goce Delcev University, Stip, North Macedonia

Далибор Серафимовски / Dalibor Serafimovski
Електротехнички факултет,
Универзитет „Гоце Делчев“, Штип, Северна Македонија
Faculty of Electrical Engineering,
Goce Delcev University, Stip, North Macedonia

Мирослава Фаркаш Смиткова / Miroslava Farkas Smitková
Факултет за електротехника и информации технологии
Словачки Технички Универзитет во Братислава, Словачка
Faculty of Electrical Engineering and Information Technology
Slovak Technical University in Bratislava, Slovakia

Петер Јанига / Peter Janiga
Факултет за електротехника и информации технологии
Словачки Технички Универзитет во Братислава, Словачка
Faculty of Electrical Engineering and Information Technology
Slovak Technical University in Bratislava, Slovakia

Јана Радичова / Jana Raditschová

Факултет за електротехника и информациони технологии
Словачки Технички Универзитет во Братислава, Словачка
Faculty of Electrical Engineering and Information Technology
Slovak Technical University in Bratislava, Slovakia

Драган Миновски / Dragan Minovski

Електротехнички факултет,
Универзитет „Гоце Делчев“, Штип, Северна Македонија
Faculty of Electrical Engineering,
Goce Delcev University, Stip, North Macedonia

Василија Шарац / Vasilija Sarac

Електротехнички факултет,
Универзитет „Гоце Делчев“, Штип, Северна Македонија
Faculty of Electrical Engineering,
Goce Delcev University, Stip, North Macedonia

Александар Туцаров / Aleksandar Tudzarov

Електротехнички факултет,
Универзитет „Гоце Делчев“, Штип, Северна Македонија
Faculty of Electrical Engineering,
Goce Delcev University, Stip, North Macedonia

Владимир Талевски / Vladimir Talevski

Електротехнички факултет,
Универзитет „Гоце Делчев“, Штип, Северна Македонија
Faculty of Electrical Engineering,
Goce Delcev University, Stip, North Macedonia

Владо Гичев / Vlado Gicev

Факултет за информатика,
Универзитет „Гоце Делчев“, Штип, Северна Македонија
Faculty of Computer Science,
Goce Delcev University, Stip, North Macedonia

Марија Чекеровска / Marija Cekerovska

Машински факултет,
Универзитет „Гоце Делчев“, Штип, Северна Македонија
Faculty of Mechanical Engineering,
Goce Delcev University, Stip, North Macedonia

Мишко Цидров / Misko Dzidrov

Машински факултет,
Универзитет „Гоце Делчев“, Штип, Северна Македонија
Faculty of Mechanical Engineering,
Goce Delcev University, Stip, North Macedonia

Александар Крстев / Aleksandar Krstev

Факултет за информатика,
Универзитет „Гоце Делчев“, Штип, Северна Македонија
Faculty of Computer Science,
Goce Delcev University, Stip, North Macedonia

Ванчо Аџиски / Vancho Adziski

Факултет за природни и технички науки,
Универзитет „Гоце Делчев“, Штип, Северна Македонија
Faculty of Natural and Technical Sciences,
Goce Delcev University, Stip, North Macedonia

Томе Димовски / Tome Dimovski

Факултет за информатички и комуникациски технологии,
Универзитет „Св. Климент Охридски“, Северна Македонија
Faculty of Information and Communication Technologies,
University St. Climent Ohridski, North Macedonia

Зоран Котевски / Zoran Kotevski

Факултет за информатички и комуникациски технологии,
Универзитет „Св. Климент Охридски“, Северна Македонија
Faculty of Information and Communication Technologies,
University St. Climent Ohridski, North Macedonia

Никола Рендевски / Nikola Rendevski

Факултет за информатички и комуникациски технологии,
Универзитет „Св. Климент Охридски“, Северна Македонија
Faculty of Information and Communication Technologies,
University St. Climent Ohridski, North Macedonia

Илија Христовски / Ilija Hristovski

Економски факултет,
Универзитет „Св. Климент Охридски“, Северна Македонија
Faculty of Economy,
University St. Climent Ohridski, North Macedonia

Христина Спасовска / Hristina Spasovska

Факултет за електротехника и информациски технологии,
Универзитет „Св. Кирил и Методиј“, Скопје, Северна Македонија
Faculty of Electrical Engineering and Information Technologies,
Ss. Cyril and Methodius University, North Macedonia

Роман Голубовски / Roman Golubovski

Природно-математички факултет,
Универзитет „Св. Кирил и Методиј“, Скопје, Северна Македонија
Faculty of Mathematics and Natural Sciences,
Ss. Cyril and Methodius University, North Macedonia

Маре Србиновска / Mare Srbinovska

Факултет за електротехника и информациски технологии,
Универзитет „Св. Кирил и Методиј“, Скопје, Северна Македонија
Faculty of Electrical Engineering and Information Technologies,
Ss. Cyril and Methodius University, North Macedonia

Билјана Златановска / Biljana Zlatanovska

Факултет за информатика,
Универзитет „Гоце Делчев“, Штип, Северна Македонија
Faculty of Computer Science,
Goce Delcev University, Stip, North Macedonia

Александра Стојанова Илиевска / Aleksandra Stojanova Ilievska
Факултет за информатика,
Универзитет „Гоце Делчев“, Штип, Северна Македонија
Faculty of Computer Science,
Goce Delcev University, Stip, North Macedonia

Мирјана Коцалева Витанова / Mirjana Kocaleva Vitanova
Факултет за информатика,
Универзитет „Гоце Делчев“, Штип, Северна Македонија
Faculty of Computer Science,
Goce Delcev University, Stip, North Macedonia

Ивана Сандева / Ivana Sandeva
Факултет за електротехника и информациски технологии,
Универзитет „Св. Кирил и Методиј“, Скопје, Северна Македонија
Faculty of Electrical Engineering and Information Technologies,
Ss. Cyril and Methodius University, North Macedonia

Билјана Читкушева Димитровска / Biljana Citkuseva Dimitrovska
Електротехнички факултет,
Универзитет „Гоце Делчев“, Штип, Северна Македонија
Faculty of Electrical Engineering,
Goce Delcev University, Stip, North Macedonia

Наташа Стојковиќ / Natasa Stojkovic
Факултет за информатика,
Универзитет „Гоце Делчев“, Штип, Северна Македонија;
Faculty of Computer Science,
Goce Delcev University, Stip, North Macedonia;



Втора меѓународна конференција ЕТИМА Second International Conference ETIMA

PREFACE

The Faculty of Electrical Engineering at University Goce Delcev (UGD), has organized the Second International Conference *Electrical Engineering, Informatics, Machinery and Automation - Technical Sciences applied in Economy, Education and Industry-ETIMA*.

ETIMA has a goal to gather the scientists, professors, experts, and professionals from the field of technical sciences in one place as a forum for exchanging the ideas, strengthening the multidisciplinary research and cooperation, and promoting the achievements of technology and its impact on every aspect of living. We hope that this conference will continue to be a venue for presenting the latest research results and developments on the field of technology.

Conference ETIMA was held as online conference. More than sixty colleagues contributed to this event, from five different countries with more than thirty papers.

We would like to express our gratitude to all the colleagues, who contributed to the success of ETIMA'23 by presenting the results of their current research and by launching the new ideas through many fruitful discussions.

We invite you and your colleague to attend ETIMA Conference in the future as well. One should believe that next time we will have opportunity to meet each other and exchange ideas, scientific knowledge and useful information as well as to involve as much as possible the young researchers into this scientific event.

The Organizing Committee of the Conference

ПРЕДГОВОР

Меѓународната конференција *Електротехника, Технологија, Информатика, Машинство и Автоматика-технички науки во служба на економија, образование и индустрија-ЕТИМА* е организирана од страна на Електротехничкиот факултет при Универзитетот „Гоце Делчев“.

ЕТИМА има за цел да ги собере на едно место научниците, професорите, експертите и професионалците од полето на техничките науки и да претставува форум за размена на идеи, да го зајканува мултидисциплинарното истражување и соработка и да ги промовира технолошките достигнувања и нивното влијание врз секој аспект од живеењето. Се надеваме дека оваа конференција ќе продолжи да биде настан на кој ќе се презентираат најновите резултати од истражувањата и развојот на полето на технологијата.

Конференцијата ЕТИМА се одржа online и на неа дадоа свој придонес повеќе од шеесет автори од пет различни земји со повеќе од триесет труда.

Сакаме да ја искажеме нашата благодарност до сите колеги кои придонесоа за успехот на ЕТИМА'23 со презентирање на резултати од нивните тековни истражувања и со лансирање на нови идеи преку многу плодни дискусии.

Организационен одбор на конференцијата

СОДРЖИНА / TABLE OF CONTENTS:

ANALYTICAL ESTIMATION OF OPTIMAL PV PANEL TILT BASED ON CLEAR-SKY IRRADIANCE MODEL	13
ENVIRONMENTAL AND ENERGY UTILIZATION OF MUNICIPAL WASTE – ONE PRODUCT, TWO SOLUTIONS	14
INTELLIGENT POWER MODULE CONTROLLED BY MICROCOMPUTER AND IMPLEMENTED IN AC MOTOR SPEED REGULATOR.....	22
COMPARATIVE ENVIRONMENTAL ANALYSIS BETWEEN CONVENTIONAL AND COGENERATION GAS-FIRED CENTRAL HEATING SYSTEMS.....	32
COMPARATIVE ANALYSIS BETWEEN BIFACIAL AND MONOFACIAL SOLAR PANELS USING PV*SOL SOFTWARE	44
TECHNO-ECONOMIC EVALUATION OF RETROFITTING A 210 MW THERMAL HEAVY-OIL POWER PLANT WITH A PHOTOVOLTAIC SOLAR THERMAL ENERGY STORAGE SYSTEM USING MOLTEN SALT: A CASE STUDY OF TEC NEGOTINO.....	45
CHARGING STATIONS CONNECTED TO STREET LIGHT POWER SYSTEM	46
ELECTRICITY PRODUCTION OF PVPP FOR ELECTRICITY MARKET	47
ENERGY MIX OF THE SLOVAK REPUBLIC.....	55
SWOT ANALYSIS OF HYDROGEN ECONOMY	59
PHYSICAL LIMITATIONS OF DIMMING OF 400 W RATED HALIDE LAMPS (A CASE STUDY).....	60
ФУНКЦИОНИРАЊЕ НА ПАЗАРИ НА ЕЛЕКТРИЧНА ЕНЕРГИЈА: МОДЕЛИ НА ПАЗАРИ НА ЕЛЕКТРИЧНА ЕНЕРГИЈА	68
EASY AND FAST ESTIMATION OF THERMAL STABILITY OF HTS MAGNETS UNDER SIMPLE SITUATION.....	76
INVESTIGATION OF TURN-TO-TURN CONTACT RESISTANCES OF LARGE-SCALE D-SHAPED NO-INSULATION HIGH-TEMPERATURE SUPERCONDUCTING MAGNETS TO ACHIEVE SHORT CHARGING DELAY AND HIGH THERMAL STABILITY.....	77
IMPACT OF CORE SATURATION ON OPERATING CHARACTERISTICS OF THREE-PHASE SQUIRREL CAGE MOTOR.....	84
PRINCIPLES AND APPLICATIONS OF ORAL ELECTROSURGERY	93
MOLTEN SALT THERMAL ENERGY STORAGE FOR RENEWABLE ENERGY: SYSTEM DESIGN, MATERIALS, AND PERFORMANCE	100
ДЕНТАЛНИТЕ ЛАСЕРИ - ПРЕДИЗВИК НА СОВРЕМЕНАТА СТОМАТОЛОГИЈА.....	110
ANALYSIS OF DEVELOPING NATIVE ANDROID APPLICATIONS USING XML AND JETPACK COMPOSE	118
ENSURING INFORMATION SECURITY IN THE DIGITAL AGE	119
CLOUD COMPUTING AND VIRTUALIZATION: CAN CLOUD COMPUTING EXIST SEPARATELY FROM VIRTUALIZATION?.....	124



THE IMPACT OF ONLINE TEACHING ON THE DENTAL STUDENTS' EXAM SUCCESS.....	131
КОМПАРАТИВНА АНАЛИЗА НА СТАНДАРДИ И МЕТОДОЛОГИИ ЗА УПРАВУВАЊЕ СО ИНФОРМАЦИСКО-БЕЗБЕДНОСНИ РИЗИЦИ НА ТЕХНИЧКИТЕ И ЕЛЕКТРОНСКИТЕ СИСТЕМИ ОД КРИТИЧНАТА ИНФРАСТРУКТУРА.....	139
УЧЕЊЕ СО ПОМОШ НА МОБИЛНИ УРЕДИ – ПРИДОБИВКИ И ПРЕДИЗВИЦИ НА НОВОТО ВРЕМЕ	140
TRANSCUTANEOUS ELECTRICAL NERVE STIMULATION METHOD IN PATIENTS WITH XEROSTOMIA	147
БИОТЕХНОЛОШКА ПРОЦЕДУРА НА ДОБИВАЊЕ НА АВТОЛОГЕН ДЕНТИНСКИ ГРАФТ ЗА СТОМАТОЛОШКИ И МЕДИЦИНСКИ ЦЕЛИ	148
PHYSIODISPENSER – AND ITS USE IN DENTAL MEDICINE	149
БИОМЕХАНИКАЛНО ПОВЕЌАЊЕ НА ЕНДОСОНИЦИТЕ	153
ДИГИТАЛНИ ОТПЕЧАТОЦИ-СОВРЕМЕН ТРЕНД НА ДЕНЕШНИЦАТА	158
DESIGN AND IMPLEMENTATION OF SCADA SYSTEMS	167
ПРЕДНОСТИ И НЕДОСТАТОЦИ ПРИ ИЗВЕДУВАЊЕ ONLINE НАСТАВА ПО МАТЕМАТИКА	174
ALGORITHMIC METHOD IN DYNAMIC DOSING SYSTEMS BASED ON WEIGHT MEASURING PRINCIPLES	181
IMPLICATIONS FOR THE ENVIRONMENTAL-ENGINEERING COMPROMISE AS A RESULT OF POWER AND ECONOMY TUNING A DIESEL ENGINE.....	189
AUTONOMOUS ROBOTIC VACUUM CLEANER	190



INTELLIGENT POWER MODULE CONTROLLED BY MICROCOMPUTER AND IMPLEMENTED IN AC MOTOR SPEED REGULATOR

Goce Stefanov¹, Vasilija Sarac²

¹ Faculty of Electrical Engineering, Goce Delcev University, Krste Misirkov 10A, 2000 Stip, North Macedonia,
email: goce.stefanov@ugd.edu.mk

² Faculty of Electrical Engineering, Goce Delcev University, Krste Misirkov 10A, 2000 Stip, North Macedonia,
email: vasilija.sarac@ugd.edu.mk

Abstract

In the paper, a V/f AC motor speed regulator based on an intelligent power module (IPM) and a microcomputer is designed and practically implemented. The ATmega 328P microcomputer controls the operation of the IPM TM 35 and generates the SPWM pulses for controlling an asynchronous 3 phase AC motor. The intelligent power module TM 35 works as a power driver that isolates and transmits the SPWM signals from the microcomputer to the AC motor. A basic goal in the design of the device is the reduction of the necessary hardware components and the price, as well as the improvement of the reliability of operation. The control and visualization of the operation modes of the V/f controller is realized with an LCD display. The operation of the controller at idle and under load has been tested.

Key words

IPM-Intelligent Power Module, Microcomputer, V/f AC motor speed regulator.

1. Introduction

An induction motor mainly works as a constant speed motor, however possible in the defined range with some drawbacks such as efficiency drop and aggravation of the power factor to operate at variable speed.

Before discussing the methods to control the speed of three phase induction motor one should know the basic formulas of speed and torque of three phase induction motor as the methods of speed control depends upon these formulas.

The speed of induction motor can be changed from both stator and rotor side. The speed control of three phase induction motor from stator side are further classified as:

- V / f control or frequency control.
- Changing the number of stator poles.
- Controlling supply voltage.

The speed controls of three phase induction motor from rotor side are further classified as:

- Adding external resistance on rotor side.
- Cascade control method.
- Injecting slip frequency emf into rotor side.

Three phase induction motor speed control principle can be made by adjusting the frequency of the input voltage to the motor. The equation used to determine the motor synchronous speed N_s is as follows [2]:

$$N_s = \frac{120f}{z} \quad (1)$$

where, f = supply frequency and z is the number of stator poles.

From the equation (1), the speed of magnetic field varies with the frequency of the voltage, but the 3-phase motor has a shaft that rotates at a speed slightly less than the speed of the magnetic field, i.e. synchronous speed. Which is called slip speed with values that are approximately 1-3% lower than the synchronous speed and depend on the motor load.

$$N = N_s(1 - s) \quad (2)$$

Where N is the speed of the motor's shaft, the unit is rpm, while s is called slip which is the ratio of the magnetic field velocity difference to the speed of the motor shaft.

From above relation factors affecting speed of induction motor are frequency, number on poles and slip. From other side torque T on AC motor is given with [2]:

$$T = \frac{P}{2\pi f} \approx \frac{V}{f} \approx \Phi \quad (3)$$

where T is torque in Nm, P is power in W, f is frequency in Hz, V is stator voltage in V and Φ is flux in Wb.

Equation (3) illustrates the so-called scalar, or V/Hz control of an induction motor. The open loop V/Hz control of an induction motor is by far most popular method for speed control because of its simplicity, and these type of speed control is widely used in industry [2]. Voltage is required to be proportional to frequency thus that stator flux Φ remains constant. This causes that the maximum motor torque T also remain constant and independent of supply frequency. In the Fig. 1 is shown the torque-speed curves.

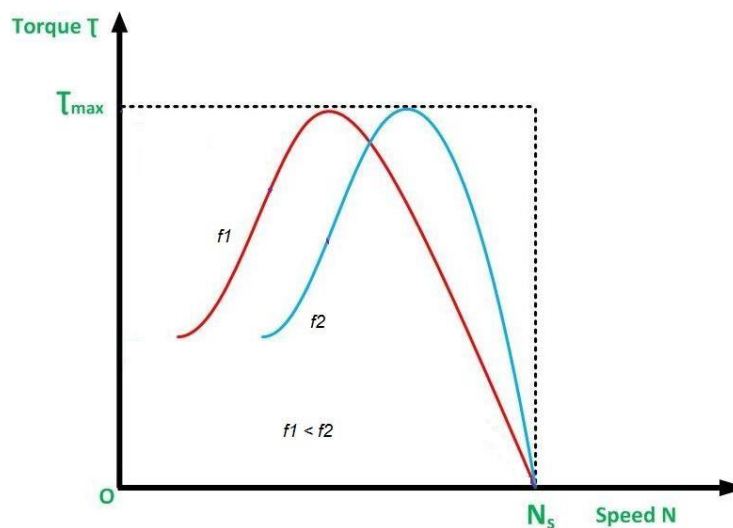

Fig. 1. Torque-speed curves.

Figure 1 shows that speed is increasing proportionally with frequency and maximum torque remains constant if supply voltage also increases with the frequency.

In this paper, the authors used aV/f controller for speed regulation on 3 phase AC motor with nominal voltage 3x380 VAC, nominal power 1.5 kW, nominal current 4.8 A, nominal frequency 50 Hz, and with number of poles $z = 8$. This controller is based on microcomputer Atmega 328P build on Arduino nano board and intelligent power module TM 35.

The test for proper operation of the designed motor controller is made so that the AC motor driven by the regulator is mechanically coupled to a DC generator with nominal voltage 100 VDC and nominal speed of 1,550 rpm. Heaters are connected to the output of the DC generator. Integrated AC DC power meter used to measure input and output energy. AC power meter is placed at the input of the controller and a DC power meter is placed at the output of

the DC generator. Brief description of the components used in the implemented regulator together with the regulator and controller information are given below.

2. Advantages of AC Motor Speed Regulator based on Intelligent Power Module and Microcomputer

Next, the major advantages of an AC motor speed regulator with an intelligent power module over solutions without intelligent power module and a generator on classic sinusoidal pattern are presented.

In the Fig. 2 the bloc diagram of analyzed 3-phase motor speed regulator is shown.

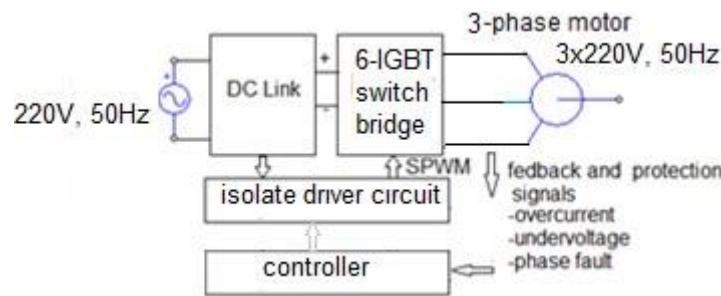

Fig. 2. Block diagram on 3-phase motor speed regulator.

The use of a microcomputer in the design of an AC motor speed controller compared to the classical configuration of controllers for generating SPWM signals provides simpler hardware architecture. The simplification resides in the design of the controlling circuit. In case of classic architecture design with analog circuits, the controller is built from analog and digital circuits including IGBT transistors for generating the sinusoidal voltage and the triangular reference voltage, required for the construction of the SPWM pattern, as shown in Fig 3, [3].

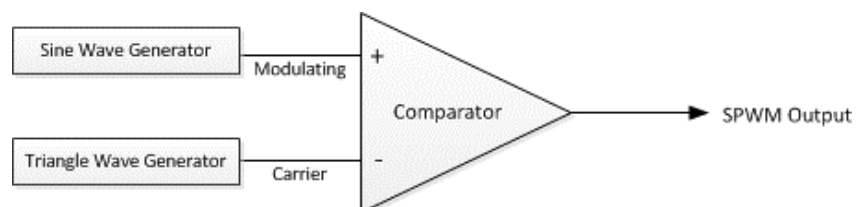

Fig. 3 Classic architecture design for generating SPWM pulses using inverter regulator with IGBT transistors.

The switching signal is generated by comparing the sinusoidal waveform and the triangular carrier waveform. The comparator output is high when the sinusoidal voltage is greater than the triangular voltage. The output pulses of the comparator are used as the gate pulses of the IGBT bridge.

In the case when the controller is implemented with a microcomputer, the sinusoidal pattern is software generated by defining on the points of switching-on and switching-off of the IGBT switches in the bridge. An example of a piece of a software code that generates pulses by variable width to drive the gates of the IGBT switches in the bridge could read as follows.

Code for generates pulses with variable width

```
const int output_1 = 9;
const int output_2 = 10;
const int output_3 = 11;
const int t = 3310;
void setup()
```

```

{
pinMode(output_1, OUTPUT); // Phase 1
pinMode(output_2, OUTPUT); // Phase 2
pinMode(output_3, OUTPUT); // Phase 3
}
void loop()
{
delayMicroseconds(t);
digitalWrite(output_1, LOW);
delayMicroseconds(t);
digitalWrite(output_2, HIGH);
delayMicroseconds(t);
digitalWrite(output_3, LOW);
delayMicroseconds(t);
digitalWrite(output_1, HIGH);
delayMicroseconds(t);
digitalWrite(output_2, LOW);
delayMicroseconds(t);
digitalWrite(output_3, HIGH);
}

```

A. SPWM generator

The PWM Generator (three-phase, two-level) block controls switching behavior for a three-phase, two-level power converter. The block:

Calculates on- and off-gating times based on the block inputs:

three sinusoidal reference voltages, one per phase, and
a DC-link voltage

Uses the gating times to generate six switch-controlling pulses.

Uses the gating times to generate modulation waveforms.

Continuous and Discontinuous PWM

The block provides modes for both continuous and discontinuous pulse width modulation (PWM). Fig. 4 shows the general difference between continuous sinusoidal PWM (SPWM) and discontinuous PWM (DPWM) waveforms.

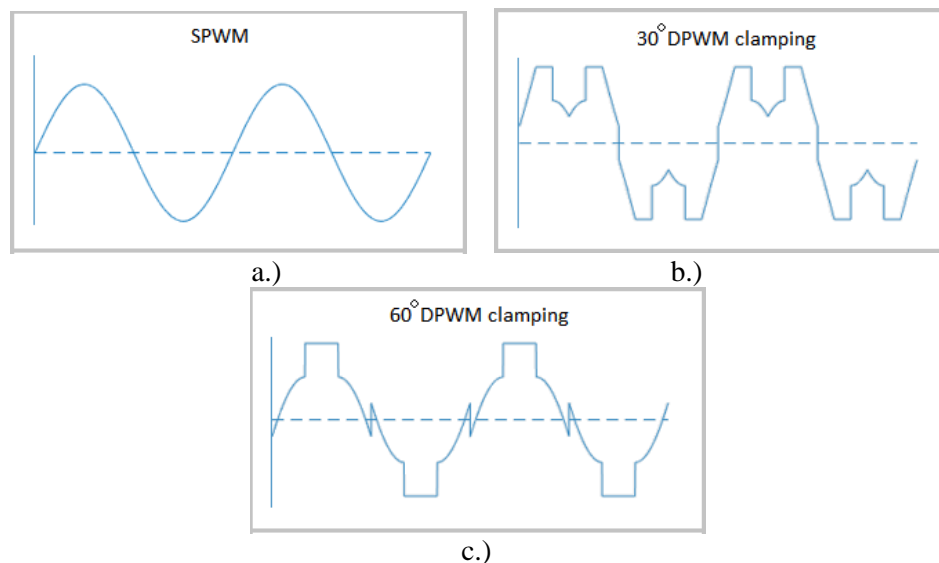

Fig. 4 The general difference between: a.) continuous sinusoidal PWM (SPWM), and b.) discontinuous PWM (DPWM) waveforms with 30° DPWM clamping, and c) discontinuous PWM (DPWM) waveforms with 60° DPWM clamping.

For discontinuous PWM (DPWM), the block clamps the modulation wave to the positive or negative DC rail for a total of 120° degrees during each fundamental period. During the clamping intervals, modulation discontinues. A waveform with 30-degree DPWM has four 30-degree intervals per fundamental period. A waveform with 60-degree DPWM has four 60-degree intervals per fundamental period.

The use of a microcomputer in the design of an AC motor speed regulator is the first advantage presented in this paper. The second advantage of the designed controller derives from the use of an intelligent power module [4], Fig. 5.

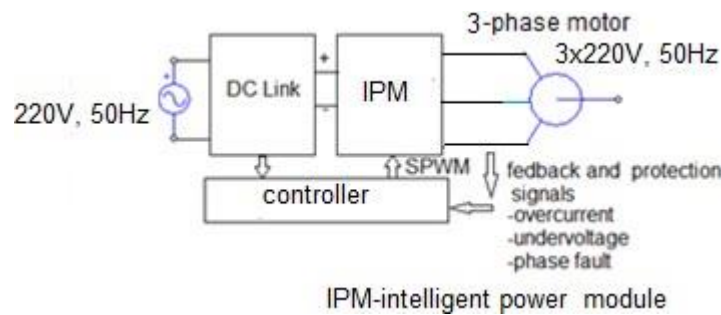

Fig. 5 Block diagram on 3-phase motor speed regulator with intelligent power module.

A comparison of Figs.3 and 5 shows the simplicity of the controller with a built-in intelligent power module.

3.Design on 3 - phase AC Motor Speed Regulator based on Intelligent Power Module and Microcomputer

Block diagram on design AC motor speed regulator based on Intelligent Power Module and Microcomputer is shown in Fig. 6. The design solution is based on an Atmega 328P microcomputer on Arduino nano board and a TM 35 intelligent power module.

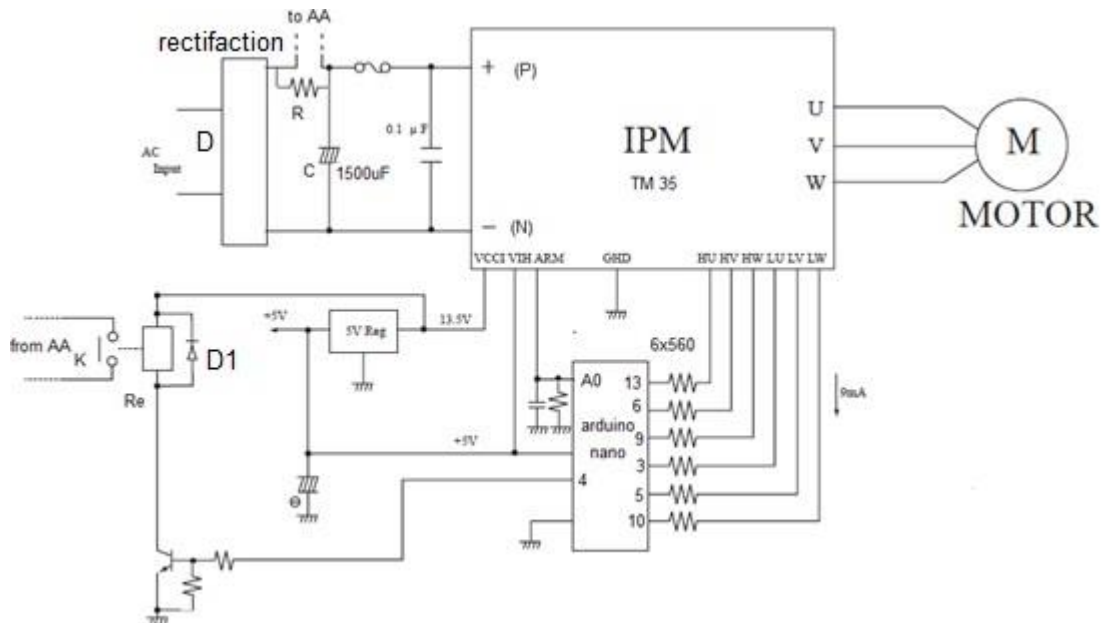

Fig. 6 Block diagram on design 3 - phase AC motor speed regulator based on intelligent power module TM 35, and microcomputer ATmega 328P on Arduino nano board.

Atmega 328P microcomputer on Arduino nano board

Arduino Nano is a microcontroller board that is similar to the Arduino Uno board but small in size and for readers who are not very familiar with microcontrollers. Microcontrollers are devices that contain a CPU, RAM, ROM, and I/O pins on a single integrated circuit and are used in electronic projects. In order to understand the Arduino boards and to use them effectively, one must first go through the pin configuration of the specific board, [6], [7]. Pinout on Arduino nano board, is represented on Fig.7.

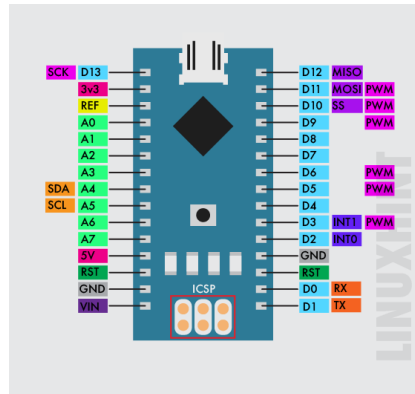

Fig. 7 Pinout on Arduino nano board.

This Arduino nano have 14 8-bit digital I/O, 7 10-bit analog input, 6 PWM output. In our application PWM outputs pins 11 and 3 are used for phase U, pins 6 and 5 for phase V, and 9 and 10 for phase W. For more information about Arduino nano, the reader is advised to consult [8].

Intelligent Power Module TM 35

Intelligent power module (IPM) TM 35 shown in Fig. 8, makes the inverter to control the speed of the 3-phase AC induction motor extremely easy.



Fig. 8 Intelligent Power Module TM 35.

Intelligent Power Module TM 35 is product of the Shindengen Electric Company, which has a 30A 600V coordinate that can be used up to 2.2 kW, 220V/380V 3-phase AC induction motors [5]. This is a hybrid integrated circuit device that incorporates the IGBT and a driver circuit set connected to the control circuit by opto-couple and switching power supply circuits for supplying 2 external control circuits. In addition, there is an over current and overload protection circuit. Therefore, the IPM TM-35 device is a convenient and easy device to design and assemble the inverter.

A rectifier circuit with the bridge diode D and the resistor device R presented in Fig 6, is limiting the over load current to the diode bridge. The initial charge at the capacitor C 1500 μ F/400V which has 4 parallel and voltage drop across the capacitor is the input voltage for IPM TM-35 by the positive (+) connected to the P terminal, and the negative (-) connected to the N terminal. When the voltage across capacitor increases to the value of 170V, the

switching power supply in IPM TM-35 circuit will start to supply 5.0V at the Vcc2 pin and 13.5 V at the Vcc1 pin, and the Re will start to work. As a result, the resistor device is short-circuited to direct capacitor current flows. DiodeD1 serves to prevent the reverse voltage of the coil Re.

3.3 Microcomputer code test results

In the Fig. 9 is shown Arduino nano board with upload code in test phase.



Fig. 9 Arduino nano board with upload code in test phase.

Obtained waveforms for phase pulse HU (pin11), HV (pin6) and HW (pin 9) for 25 Hz and 50 Hz frequencies, are presented in Fig. 10.

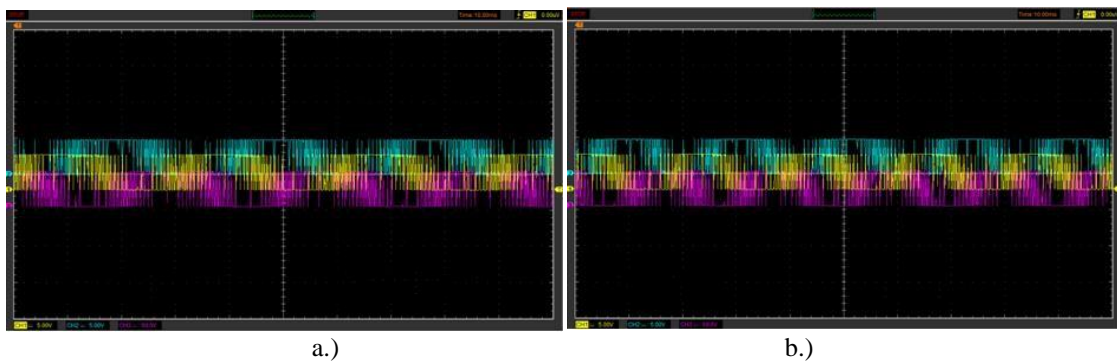
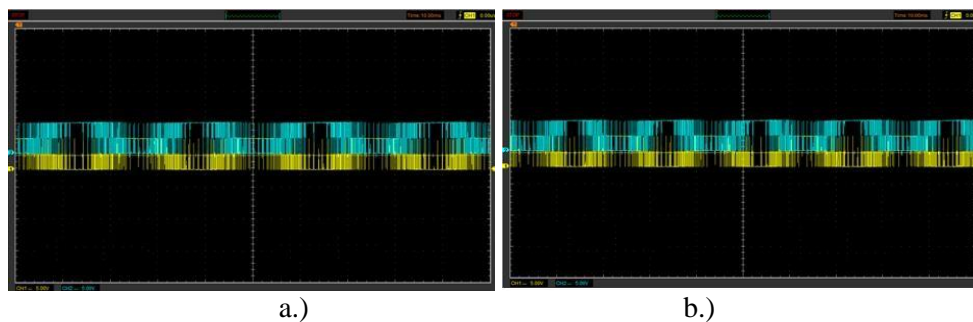

Fig. 10 Waveforms for phase pulse with horizontal 10 ms/div: a.) HU (yellow), HV (green) and HW (purple) for 25 Hz, and b.) HU (yellow), HV (green) and HW (purple) for 50 Hz.

Fig. 10 a.) and b.) shows that the phase pulses generated by the microcomputer are phase shifted for 120° .

Fig. 11 a) and b) shows waveforms for phase pulse HU-LU (pin11-3) for 40 Hz and 50 Hz frequencies, while on Fig. 11 c) phase pulse HU-LU dead time is given.





c.)

Fig. 11 Waveforms for phase pulse HU(yellow)-LU (green): a) for 40 Hz, b.) for 50 Hz, and c) HU-LU dead time.

From Fig. 11 a.) and b.) it can be seen that the phase pulses HU (yellow)-LU (green) generated by the microcomputer are phase shifted for 180° . Also, from Fig. 11 c.) it can be seen the dead time on the phase pulses HU (yellow)-LU (green). This dead time ensures that the switching-on of the two IGBT switches in the same half bridge does not overlap. In the specific case, the dead time is about $5 \mu\text{s}$.

4. Results of the experimental work of the design AC motor speed regulator

For testing, measurement, visualization and data log of the operation of the designed 3-phase AC motor regulator, an integrated AC DC power meter and mechanically coupled on the AC motor by a DC generator shown in Fig.12 is used. The AC motor data was $3 \times 380\text{V}$, 50 Hz, A, 8 poles, $N_s = 750 \text{ rpm}$, and the DC generator data was: nominal voltage 100 VDC, and nominal speed 1,550 rpm.

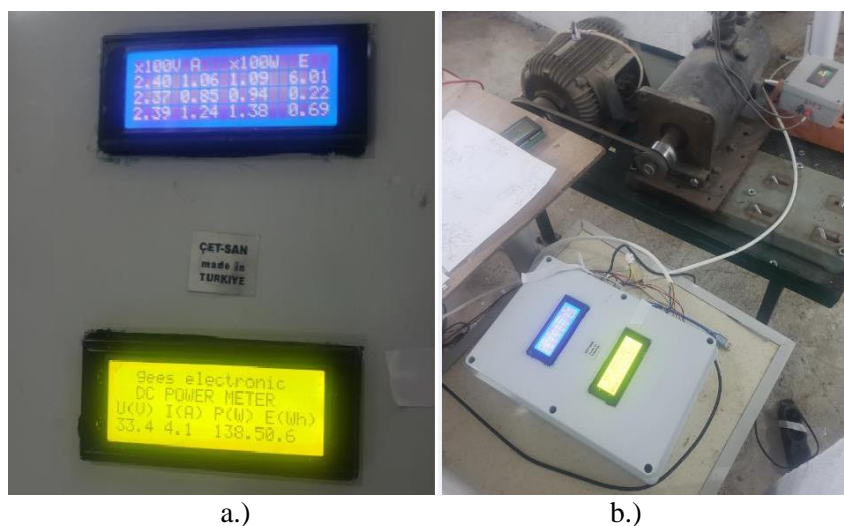

a.)

b.)

Fig. 12. Realized devices used for testing on AC motor regulator: a.) Integrated AC/DC power meter, and b.) mechanically coupled on the AC motor by a DC generator.

The integrated power meter provides the possibility to display input and output energy, power, current, and voltage data on LCD screens and stored them in a compatible EXCEL® data log file. Realized AC motor speed regulator with microcomputer and IPM TM 35 is shown in Fig. 13.

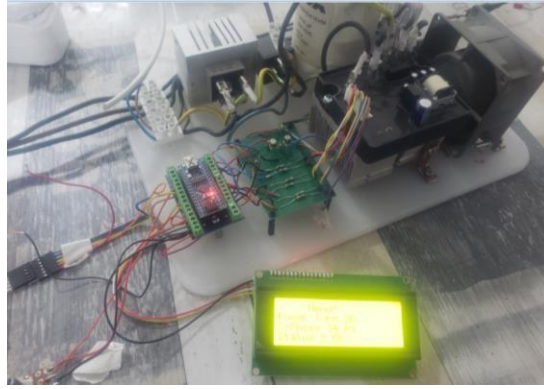

Fig. 13 Realized AC motor speed regulator with microcomputer and IPM TM 35.

Table I consist of given data for input to the AC regulator, the input current I_{in} , input voltage V_{in} , power factor $\cos\phi$, and input power, as well as DC generator's output data such as output current I_o , voltage V_o , and output power P_o . The data is given for change on motor frequency f_m on AC motor regulator in the interval from 1 Hz to 50 Hz, with 5 Hz step. N_m and N_{DCg} are measured speed on the shaft of the AC motor and the DC generator, respectively. Table I also have the calculated data for the torque T (Nm) and the efficiency coefficient η (%).

Table I:

f_m (Hz)	I_{in} (A)	V_{in} (V)	$\cos\phi$	P_{in} (W)	I_o (A)	V_o (V)	P_o (W)	N_m (rpm)	N_{DCg} (rpm)	T (Nm)	η (%)
5	2.44	244	0.52	307.2	1.1	8.16	8.94	72	151	40.74	2.91
10	1.21	244.3	0.47	137.4	2.31	16.98	39.22	145	303	9.04	28.54
15	2.84	244.5	0.43	299.2	3.56	25.81	91.76	216	452	13.22	30.66
20	2.74	244.7	0.45	302.8	4.03	33.29	134.11	287	595	10.07	44.28
25	3.98	244.7	0.47	457.8	5.31	42.12	223.5	356	732	12.28	48.82
30	5.04	244.7	0.48	591.9	6.6	50.83	335.27	421	858	13.42	56.64
35	6.16	244.7	0.5	753.7	7.44	57.2	425.82	487	979	14.77	56.49
40	7.50	244.6	0.51	936.3	8.45	64.24	543.08	553	1091	16.16	58.00
45	8.77	244.6	0.53	1136.4	9.26	70.27	650.69	620	1206	17.50	57.25
50	10.40	244.1	0.53	1348.8	10.29	89.26	918.61	666	1230	19.34	68.10

Discussion of the results of the experimental testing:

The main task in the paper was the design and implementation of an AC motor regulator with a microcomputer and IPM. However, some minor omissions were necessary done in the experimental testing phase, e.g. in the calculation of the torque T , the losses of the rectifier and of the inverter in the intelligent power module were neglected. Additionally, the measured input power is assumed to be the same as the power supplied to the motor, although. Clearly this is not the exact power delivered to the motor shaft as its efficiency is not known. The DC generator used as a coupled load with the AC motor does not provide the possibility to load the motor with a constant mechanical load for all operating frequencies from the regulator (starting from 0 to 50 Hz). That affects the calculation of the torque and efficiency coefficient given in Table I. However, the most important fact that should be considered is that the generated torque at low speeds was large. It shows that the solution fulfills one of the basic requirements for such systems to provide a large moment at low speed, very important fact for AC motor starting characteristic. Furthermore, it can be seen from Table I that for an input frequency of 50 Hz the torque is close to 20 Nm, which is the moment according to the motor data for a synchronous speed of 750 rpm and a frequency of 50 Hz.

Conclusions

In the paper, the main task was to design, implement and experimentally test a 3-phase AC motor speed regulator based on a microcomputer and an intelligent power module. The use of a microcomputer and IPM has large influence on the reduction of hardware components and thus the price of the device in relation to solutions where analog circuits are used to generate sinusoidal pulses to control the IGBT switches in the inverter and driver circuits as a coupling between the control part and the IGBT the inverter. During experimental testing phase, as a result of the absence of a real constant mechanical load, the designed AC motor speed regulator was loaded with a variable load consisting of a DC generator and output heaters. Such a load showed that the solution provides the motor operation with a high starting torque and a maximum developed power of 1,348 W. This was a good indicator that the goals set in the paper have been realized.

References

- [1] Williams W. B., (2006). Principles and Elements of Power Electronics, University of Strathclyde, Glasgow.
- [2] Leonhard W., (2001). Control of Electrical Drives. Springer, Berlin, Heidelberg, New York, pp.241-301.
- [3] David Munos O., (2011), Design Strategy for a 3 -phase Variable Frequency Drive, Electrical Engineering Department, California Polytechnic State University, USA.
- [4] Sansong W., Hemwat B. and Tunlasakun K., (2019), The Development of 3-Phase Inverter Motor Control for The Small Rice Milling Machine, International Conference on Applied Electrical and Mechanical, September 4-6, Nakhon Phanom, Thailand.
- [5] <https://www.electronicsonline.com/arduino-speed-control-3-phase-induction-motor-by-tm-35-v-1>
- [6] Atmel AVR, (2018) 48A/PA/88A/PA/168A/PA/328/P, Microchip Technology Incorporated, All Rights Reserved.
- [7] Atmel ATmega, (2014), 640/V-1280/V-1281/V-2560/V-2561/V, Atmel Corporation, 1600 Technology Drive, San Jose, CA 95110 USA.
- [8] <https://www.theengineeringprojects.com/2018/06/introduction-to-arduino-nan.html>



