



## REMOTE MANAGEMENT IN SYSTEMS FOR IRRIGATION OF SOLAR ENERGY BUNARIES IN THE VITICULTURE

**Dimitrija Angelkov<sup>1</sup>, Violeta Dimovska<sup>2</sup>, Efremco Nikolov<sup>3</sup>, Fidanka Ilieva<sup>2</sup>**

<sup>1</sup> SOU "Kiro Spandzov-Brko", Siska bb, Kavadarci, RNM

<sup>2</sup> Faculty of agriculture, University "Goce Delcev", Krste Misirkov bb, Stip, RNM

<sup>3</sup> School of agriculture and forestry, "Gorce Petrov", Siska bb, Kavadarci, RNM

\*Corresponding author: dimitrijaa@yahoo.com

### Abstract

The cultivation of the vine by the people has been dated for centuries or thousands of years, yet the progress of knowledge in the cultivation of the vine has grown enormously over the last fifty years.

Mass production with high-grade grape varieties, wine and table, thick planting, the use of fertilizers, the application of irrigation, and the acquisition of high yields, contributed to the intensification of conditions for disease development, harmful insects and weed development. For that purpose, mobile solar aggregates are very suitable today for agriculture (viticulture, fruit growing, crop production, gardening, animal husbandry, etc.), especially in those locations where there is no possibility of availability of power supply, but also in cases where we have organic food production, because they satisfy even the most stringent environmental standards.

More recently today, the world is working on the intensive development and application of mobile solar generators that include solar tracking systems and they find application in agriculture.

**Key words:** *Grape production, Remote management, Irrigation systems*

### INTRODUCTION

In this paper we show how the solar energy is used by the farmers in the Republic of Macedonia for irrigation and management of the distance using the GSM module.

Over the last three decades, a number of advanced process controls have been installed in production plants. The need for upgrading these systems over an Internet network provides the ability to design and analyze remote-controlled systems with immense stability and reliability. In the last two decades, web based systems in real time play an important role in the production of a quality product in our case raw grapes. This paper is a solution that allows us to obtain quality and remote-controlled equipment for low-cost equipment, which is specialized for activating and disconnection of pumps powered by solar energy and for irrigation of vineyards. Use

existing available technologies that are free to use and in combination with the new solutions from this paper, a managed system is run that will work seamlessly with mechanisms through which all errors will be annulled.

Several systems are offered that offer cheap solutions that will meet the requirements of the growers in the Republic of North Macedonia.

The solutions are characterized by a short reaction time, at any time and under any conditions, to respond in a reverse manner without the need for additional intervention by users and system supervisors. The application of communication technology services to GPRS, EDGE and UMTS with the regional management and management of water systems ensures a quality system operated and monitored remotely.

Measuring the current value of water supply facilities, such as water, water pressure in the pipeline, top, bottom and current tank levels in reservoirs, pump status and exclusion devices have become a necessity today.

The transfer of these data from the peripheral stations to the central unit, linking them to a single system has been made through the UKV radio link.

The infrastructure security costs needed to handle the UKV radio connection and the inconsistency of data transmission have caused UKV's radio link to become a thing of the past.

The new way of connecting is through GPRS connectivity that does not need a separate infrastructure because it uses existing communication, and the transmission itself is safe, fast and accurate. GPRS connectivity enabled us to react quickly in case of any

disruption, while at the same time significantly reducing the costs associated with the round and control of water supply facilities.

The transmission of measured values from the peripheral stations to the distribution center, as well as the collection of information as indicated by using GPRS communication technology is something new in our wine-growing region. The status display and data processing is provided via mobile phones and the Internet, in order to ensure mobility with the control center and individual peripheral cells from anywhere regardless of distance and without the need for additional infrastructure investment.

At the same time, the use of GPRS technology significantly reduces the cost of communication.

#### **REMOTE MONITORING AND WATER SUPPLY CONTROL USING GPRS TECHNOLOGY**

Modern water distribution systems require continuous monitoring of water flow, water pressure in the pipeline, water level in the reservoirs, pump status and closing bodies, as well as other necessary parameters through their transfer to the remote control center. In addition to remote monitoring, the system must also provide a secure remote control with water pumps, regulating the locking of valves and the like.

At the same time, the system must also provide feedback, ie confirmation of the executed order.

In addition to the above, the system must also provide reliable reception and transmission of signal and information for future measurement control equipment.

The present mode of communication and connection of peripheral objects with the control center is achieved through the UKV radio link, which as such is subject to:

- Uncertainty and sluggishness in data transfer
- Meteorological impacts
- The congestion of communication channels
- Dependent on the configuration of the terrain
- Reflection of the signal, etc...

In addition to the above-mentioned shortcomings in the operation, this way of communication already at the very beginning required a large investment in the radio-

communications infrastructure UKV needed for radio link operation.

It was necessary to prepare project documentation for a radio connection and to obtain the necessary annual licenses with the competent institutions.

The use of a radio link was paid as a fee for radio frequency utilization.

Recognizing the above-mentioned shortcomings of the UKV radio connection, the data transmission was changed using a GSM communication link.

This was a good time, but communication using the GSM connection showed some drawbacks:

- The high cost of data transfer, because the calculation is done according to the time of the opening
- Relatively slow transfer of data about 9.6 KB / sec
- The connection is made by reference to a given number
- During a connection of about 45 seconds
- Relatively long data transmission time
- Only one link is possible at the same time.

To avoid the disadvantages of GSM and FM radio and to access remote data transfer from one another, as well as to connect to peripheral facilities for the supervision centre in a single system requires the implementation of GPRS communication technology.

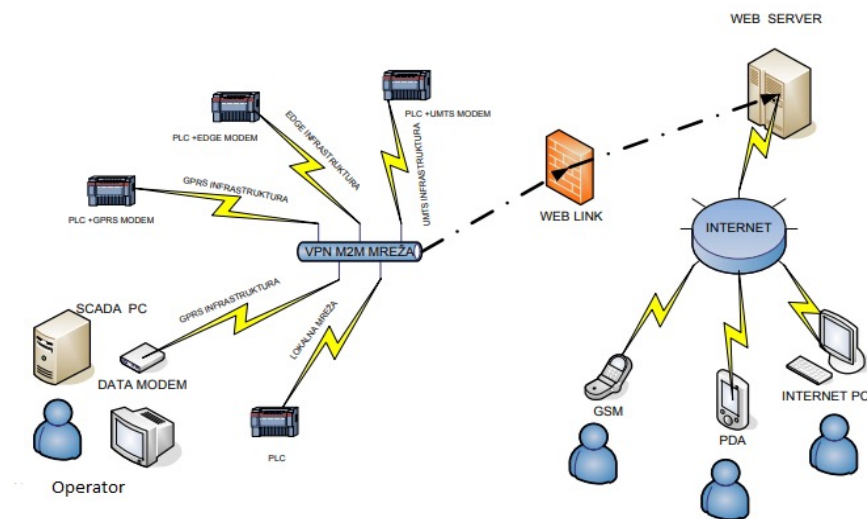

Figure 1. GPRS technology

### BASIC POINTS AND THEIR CHARACTERISTICS OF GPRS

General packet radio service or shorter GPRS is defined as an additional service on the GSM network which, when added to the packet transmission protocol provides shorter connectivity time and faster and safer data transfer.

GPRS supports transmission speeds of 20 to 30 kbps (theoretical maximum is 171.2 kbps) and provides a permanent connection that does not charge the connection time but the amount of data transmitted.

In today's GSM 2.5G network, GPRS is the most important step towards next generation 3G networks, for which GPRS is the basis for communication.

Telemetry is defined as the transmission of the measured values of the observed physical quantities in the central supervisory point, where these values can be processed and based on them, information can be obtained which can be used for the remote-control processes.

### GPRS TELEPHONE SYSTEM

GPRS telemetry system is the name of the new generation telemetry system, and includes the use of all public infrastructure networks and the protocol for network communication.

By using the GPRS connection for data transmission to the supervisory control system (shorter NUS), in addition to the aforementioned advantages of GPRS, they realize that there are other options that the said system offers for its communication concept to the users.

By using GPRS services in the "leased" infrastructure, it also provides the user with notifications via SMS, fax and e-mail.

The way of functioning sense is described in a system that collects all measurements of water supply facilities and a GPRS connection, so the collected data, at regular intervals, sends control to a computer. All communication, respectively. Control, communication and management of water supply facilities takes place in a closed VPN network. In order to use the VPN service,

this request must be for the authorized person in the company's mobile network.

Upon request and approval by the mobile operator, each member receives a VPN card with your PIN, which he defines access levels and privileges. At the request of an authorized person, at any time, change the level of users or revoke the card. So only a member of the VPN network can be monitored at the factory and allow the user to manage and with the installed equipment, a water supply system, other than what must be a member of the VPN network must know the password and password for the management level of installation suitable water tanks or pumping stations. At the time of the change of each reference value, all authorized persons in the form of SMS messages receive information about the change in the status or value of the user. Control of the water supply system is possible, except within the VPN network, as well as on the Internet.

In fact, if you want, the user is enabled on the web server, periodically, sending data on the state of the measured values of the water supply system. Anyone who knows the correct password and password can have an insight into the status of the water supply system being watched over the Internet from anywhere in the world. On the web server, in addition to the status display,

statistical processing of the measured values was made. We must emphasize that the management of the water supply system can be done within the VPN network, while over the Internet can be monitored only on the system, because there is no possibility of entering the Internet in the VPN network.

### FUNCTIONAL LOOK AND SECURITY WITHIN THE COMMUNICATION WITH USING GPRS TECHNOLOGY

GPRS technology was adopted and approved by the European Institute of Technology. Telecommunication standards ETSI and consists of a set of standards to be noticed by equipment manufacturers, network elements and mobile terminals, as well as the mobile telecommunications operators themselves. Several standards are embedded in the standard security itself to protect the "privacy" of data and

of the senders, including the most important:

- Data encryption is done on GPRS / UMTS / EDGE connection between your mobile phone terminal and operator system
- allows the authorization of mobile stations by the Vip or T-mobile operator at any time, the system recognizes the sender and checks the identity through appropriate tests.

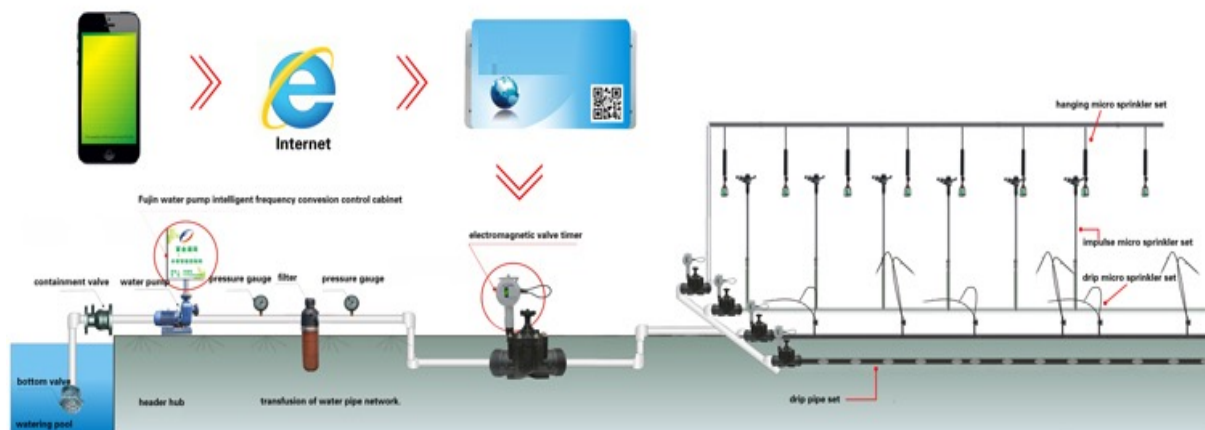

Figure 2. Indication of irrigation by means of pumps operated via a mobile phone

### REMOTE MANAGER

All equipment with electronic output (analogue or digital) can be controlled from a remote monitor and those that have the possibility of electronic input can be managed.

Parameters that can be read on a PC or PDA, for example, or a GSM / GPRS module (with an active GPRS service and a web out) for example:

- Water flow (electricity and total)
  - Water level in water - current, minimum and maximum
  - Water pressure in pipelines
  - Water turbidity
  - The residual concentration of chlorine in water
  - Concentration of chlorine in the air
  - The pump status
  - Valve status
  - Status of the hydro-blocks
  - The status of other equipment such as compressors, hydraulic shock compensators, etc.
  - Notification of entry to a remote object
  - A power failure report
  - Alarm
- SMS messages:
- ALARM (location) - power failure
  - ALARM (location) - the level of water in the water is too low - the danger of operation of

- the pump is dry
  - ALARM (location) - The water level in the water is too high - the risk of spillage
  - ALARM (location) - the door of the building is open
  - ALARM (location) - network service is established
  - ALARM (location) - the pressure of the water in the pipeline is too low
  - ALARM (location) - flow of water above the set value
  - ALARM (location) - concentration of residual chlorine in large / small water
  - ALARM (location) - the appearance of chlorine in the air
  - ALARM (location) - the valve is not fully closed / open
- Management:
- Change in the level of water in which the pumps are switched on / off
  - Change in the pressure of the water in the pipeline in which the pumps are switched on / off
  - Selecting the pumping order
  - Change in the concentration of the rest of the chlorine
  - Setting the operation of the plant - manually / automatically
  - Reset the default values



**Figure 3.** Solar collector through which the irrigation pump is powered

**ADVANTAGES OF THE WORK OF THE SYSTEM FOR SUPERVISION AND MANAGEMENT**

The described system of remote monitoring and management of water supply systems allows the user to have a number of advantages and benefits, among which the most important in relation to FM radio connection are:

- Continuity of connection independent of external influences, field configuration, meteorological conditions.
- Significantly lower installation costs because existing HT-mobile or VIP networks are used by an operator
- Significantly lower maintenance costs
- Low power consumption related to GSM radio connection:
- Great security in communication
- High speed data transfer - 115 kb / sec
- The price of the transfer is significantly lower, because the calculation is done according to the amount of the transferred data
- The connection is made by calling a static IP address
- The current connection is established as a permanent connection
- The duration of the transmission is short
- The number of concurrent connections is unlimited
- Fast and reliable insight into the state of the system over the Internet
- Manage your computer via a GPRS connection
- PDA control via GPRS connection
- Management via GSM via GPRS connection
- Security against attempts for unauthorized control of the system using multi-level user protection

- Continuous monitoring of 24 hours and recording of all parameters of the event followed in the process of measuring and controlling the equipment

However, the main advantage of the GPRS telescope is the mobility and security of the surveillance and management of water supply systems. Supervision and management are designed to provide a breakdown or if the requested value is reached through today's known SMS messaging channel, the event will be reported to the responsible person. For example, a power failure in a plumbing facility will consequently be notified to electricians, managers and technical director.

In the example above, in the event of a power failure, the system remains in the control function for 24 hours from the moment of power failure, since it is powered by its own source, which is an integral part of the device. System overview of the system is available anytime and anywhere by connecting to the Internet server, allowing the current status of all elements to be managed, as well as a review of the processed statistics of all analogue and digital sizes such as pressure on the gas pipeline, the water level in the water tank and the like.

The GPRS telemetry system connects to the web server and periodically, at predefined times when the time interval is switched on, sends data on the measured physical quantities and status of the measurement and control equipment.

The data is stored and processed on the server side. The authorized user can see the status of all water supply system facilities, while at the same time providing a quick insight into the status of all significant parameters are monitored and analysed. Viewing all the parameters that are followed during the time when some changes are made are made possible by a subsequent analysis of all events, and increased security of predicting possible future events. In the graphic display it is possible to select a view for a certain period, or a view for a particular day, where there is a visible change in a specific time unit. The ultimate advantage of this monitoring and management system is its mobility and a variety of management interfaces. One of them is SCUBA Duplika which represents a novelty in SCADA for managing water supply systems. The advantage is, except for a friendly graphical user interface, and Jscada itself, which is written in Java.

Java scada is compatible with all existing operating systems and is thus flexible in terms of installing existing or new computers. In cases where our computers are not available, remote management may be via a mobile device that supports GPRS data transmission and has an integrated web browser, connecting to a telemetry server for GPRS. It is important to note that regardless of the way the information is viewed or how the stations are operated, all measured and managed variables are programmed at any time flexible to users.

### **DESCRIPTION OF THE SYSTEM AND THEORY**

The system features are simplicity, practicality and relatively low cost.

It is basically based on the ATMEL ATmega328P microcontroller, which is tested in practice and features stability, quality and low cost, which allows application in irrigation systems. The system monitors the humidity of the soil and depending on how much the soil is damp, returns to the server side the humidity level. Depending

on this, the operator can activate the pump or the pump to be put into automatic mode itself to activate if there is water in the tank. If there is no water, the system will generate a signal and the operator will know that there are not enough water in the wells to fill the tank. The system has an LCD display to display the status locally. The real time is also displayed on the display.

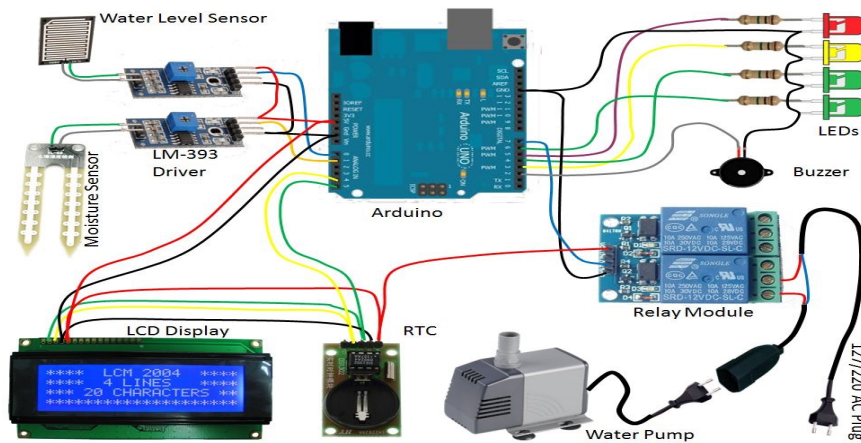
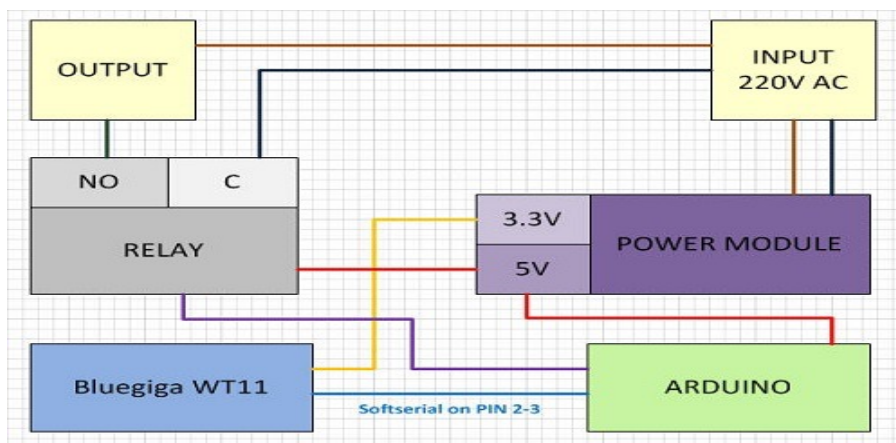

**Figure 4.** Connection diagram for humidity sensors, controller, display, diode and pump

This report serves as an overview of the use of solar energy by farmers and farmers in the United States that identifies trends and future potential. Agriculture increasingly includes quality remote applications through which all time parameters are monitored. These applications are low-cost and efficient in their work, but in the last decade, agriculture has noted the number of systems connected to the network and the average size of solar systems is increasing. Some solar thermal installations are also used in agriculture, but are currently overshadowed by solar electric power. Although solar energy can reduce energy costs volatility and greenhouse gases, its high capital costs and lower average cost of competitive fuel remain obstacles to growth. For this reason, the development of solar energy is aimed at politics. The report examines the regulations and incentives available to farmers and farmers, and recently increased installations and examined major financial impacts. The development of

solar energy in agriculture varies considerably by the state, incentives and energy prices. In this project, we'll see how we can manage a variety of devices using a mobile phone under the Android platform. The project is based only on switching on / off the device, i.e., when switching on / off the relay with any device can be powered, in our case a water pump. The project uses the Arduino Pro Mini development system, as well as the Bluegiga WT11 Bluetooth module.

The device consists of two parts: Hardware, receiving commands and turning on / off the output relay and Software running under the Android platform and sending hardware commands through which the current state of the device is displayed. These two elements communicate via Bluetooth connection. The block diagram of a part of the device on the device is shown in the picture.



**Figure 5.** Bluetooth module connected to the arduino programmable logic controller

The basic element of the device is the Arduino IDE Pro Mini development system. It manages the output relay (which is powered by a 5V DC voltage) based on the command it receives from the Bluegig WT11 Bluetooth module.

To operate the device, a power module is required, which supplies all components of the system. The power supply module should provide 3.3V and 5V DC.

An automatic irrigation system for farmers or any user who needs to fill the reservoirs, as well as to use the water supply.

The system consists of a pump motor, together with an LCD and GSM modem controlled by a microcontroller.

The system allows users to remotely switch on / off the engine. The system consists of an automatic water measurement system that automatically switches off the pump motor as soon as it senses that the water supply is stopped and the engine is dry.

Our system uses a GSM modem to send and receive user commands and then manages the pump engine based on user SMS. The system also consists of infrared sensors to detect the flow of water through the tube until the flow of water is detected through the pump's pump tube. As soon as the sensor detects that the water supply is stopped, the microcontroller is notified of the dry start state. The system now informs the user that it has turned off the engine when it noticed a dry condition.

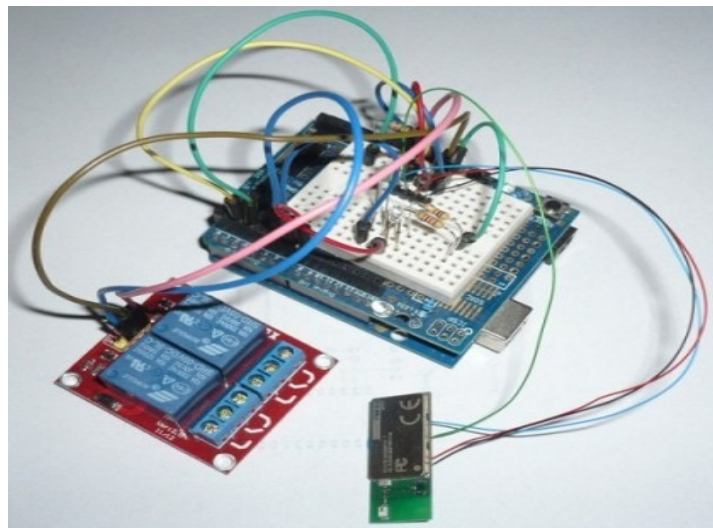

**Figure 6.** Communication system with mobile phone via Bluetooth module

Arduino and Bluetooth module are connected to serial communication. A part of the microcontroller software, which is in charge of

their communication, was developed with the help of Software Serial Library.



**Figure 7.** Complete system placed in the box



The electrical pattern of the device, as well as the PCB designed in the Eagle software, can be found at the end of the text. In the picture you can see what the prototype of the device looks like and the picture shows the finished device.

The RX pin of GSM is connected to the TX pin from the arduin while the TX pin from GSM is connected to the RX pin from the arduin. The line view is shown below.

ARDUINO

TX ----- RX GSM modem  
 RX ----- TX

The zeros of the connection links are connected at the same point.

The whole system works with SMS messages. Below is the program code that is with special comments explained each line separately.

**PROGRAM CODE:**

```
int LED = 8; // an ice-connected diode 8
int motor = 9; the water pump is connected to pin 9
int temp = 0; // auxiliary variable
int i = 0; // auxiliary variable
char str [15]; // initialization of a string with a length of 15
void setup () // start of the main initialization
{
Serial.begin (9600); // serial communication at a speed of 9600 characters per second
pinMode (motor, OUTPUT); // initialization of the engine outlet from the water pump
pinMode (LED, OUTPUT);
digitalWrite (motor, LOW);
digitalWrite (LED, LOW);
delay (20000); // time delay of 2 seconds
delay (20000); // time delay of 2 seconds
delay (20000); // time delay of 2 seconds
Serial.println ("AT + CNMI = 2,2,0,0,0"); // serial data transfer for SMS commands
delay (1000);
Serial.println ("AT + CMGF = 1"); // serial data transfer for SMS commands
delay (500);
Serial.println ("AT + CMGS = \" + 38971826952 + \" r"); // serial data transfer for SMS commands
delay (1000);
Serial.println ("System is ready to receive commands."); // Text sent via SMS containing a message
that the system is ready to receive commands
delay (100); // time delay of 0.1 second
Serial.println ((char) 26); // ASCII code for CTRL + Z
delay (1000);
}
void loop () // main loop
{
if (temp == 1)
{
check (); // activate the check function
temp = 0;
i = 0;
delay (1000);
}}
void serialEvent () // if there is a serial transmission then check the sign of the slash is activated
{
while (Serial.available ())
{
```

```
if (Serial.find ("/"))
{
  delay (1000);
  while (Serial.available ())
  {
    char inChar = Serial.read ();
    str [i ++] = inChar;
    if (inChar == '/')
    {
      temp = 1;
      return;
    }
  }
}
void check ()
{
  if (! (strcmp (str, "motor on", 8))) // check if the engine is activated
  {
    digitalWrite (motor, HIGH);
    digitalWrite (LED, HIGH);
    delay (1000);
    Serial.println ("AT + CMGS = \" + 38971826952 \"\n r"); // Send a message to a mobile phone
    delay (1000);
    Serial.println ("Motor Activated"); // SMS text you want to send
    delay (100);
    Serial.println ((char) 26); // ASCII code for CTRL + Z
    delay (1000); // time delays
  }
  else if (! (strcmp (str, "motor off", 9)))
  {
    digitalWrite (motor, LOW); // turn off the engine
    digitalWrite (LED, LOW); // turn off the light diode
    delay (1000); // time delays
    Serial.println ("AT + CMGS = \" + 38971826952 \"\n r");
    delay (1000); // time delays
    Serial.println ("Motor deactivated"); // SMS Message that the engine has been deactivated
    delay (100);
    Serial.println ((char) 26); // ASCII code for CTRL + Z
    delay (1000);
  }
  else if (! (strcmp (str, "test", 4)))
  {
    Serial.println ("AT + CMGS = \" + 38971826952 \"\n r");
    delay (1000);
    Serial.println ("The System is Working Fine.");
    // SMS message that sends the mobile phone to our phone
    delay (100);
    Serial.println ((char) 26); // ASCII code for CTRL + Z
    delay (1000);
  }
}
// ----- end of the program ----- //
```

The GSM / GPRS shield works primarily with Arduino sending a communication sketch through the terminal, then connecting to the GSM / GPRS shield.

It's important to have a shield especially the power that connects to the Arduino microcontroller, because without an extra external powerful shield it cannot be connected to the cellular network. You need to connect to the network to protect your computer and start the terminal after you press the "PWR" button GSM / GPRS display. When connecting to a network, the blue guidance with the name "NET" starts flashing and the shield sends a response to the terminal.

The terminal must be configured as Arduino speed 9600. After that the shield is ready for use. Shield is used with the previous described commands, allowing all basic functions like a normal mobile phone. When sending SMS messages, you must enter the number of the SIM operator whose SIM card is used, because otherwise the messages will be late or not at all. The module can also be used with the Arduino scheme, so it is necessary to define in the scheme

all orders are fine and send them through a sketch of a shield instead of a terminal.

The advantage of using a sketch over the terminal is what makes it easy to use the screen, we may be able to set an automatic action or reduce the requirements for entering a command terminal. The screen connects to the planned location on the screen and is defined in the sketch, and you must download a command library for that screen on the Internet. The screen should be pushed into the screen or wire so it can be connected and comes in white and blue.

Initially, the device should have a keyboard that was supposed to enable management, but this was not achieved. No device and no keyboard work great and performs all the functions that are made they can request a mobile device.

It can receive and receive calls, send and receive SMS messages, and display information on the screen. The problem that arises when making the device is a failure of the rectifier that comes with the GSM / GPRS shield. The device's adapter works great despite sending SMS messages.

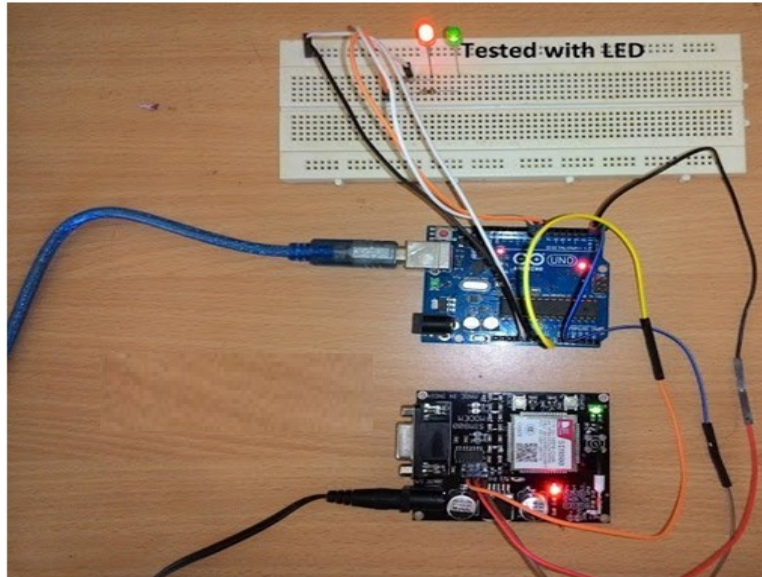

**Figure 8.** Test version of GSM module in combination with Arduino controller

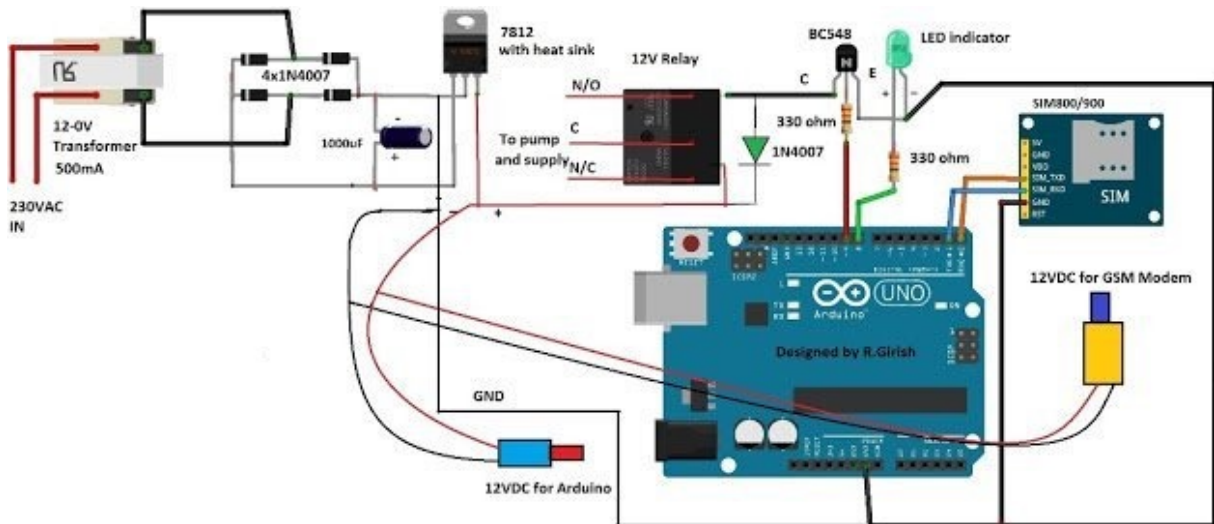

Figure 9. Test version of GSM module in combination with Arduino controller and relay for pump

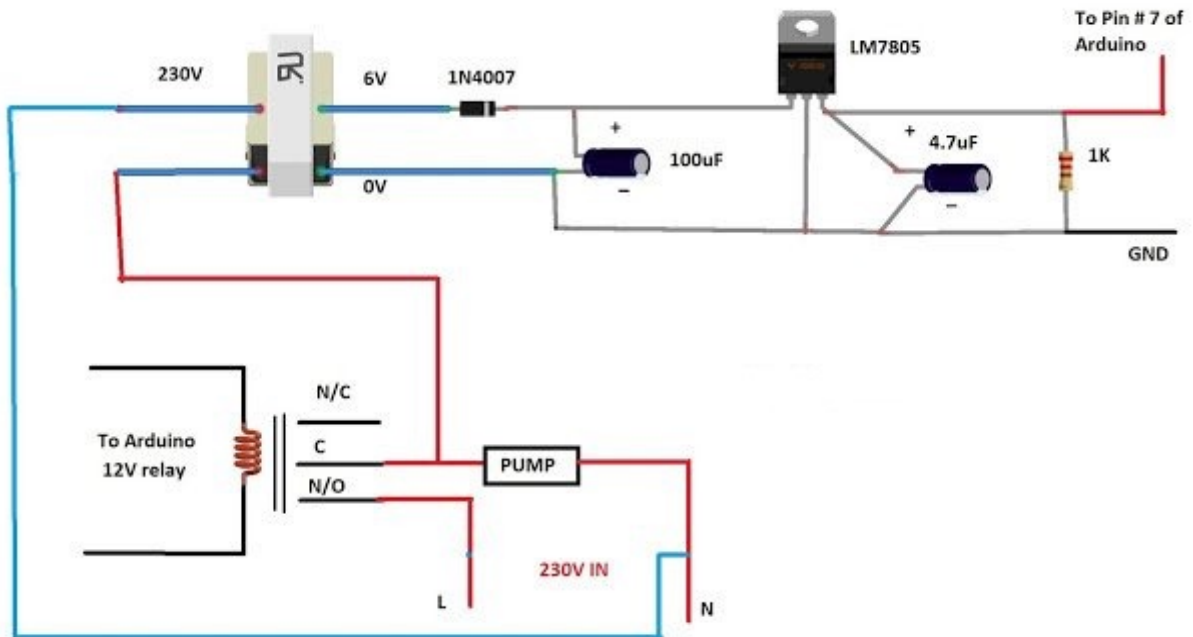

Figure 10. Solution for the return connection of the pump

### LIST OF PARTS

- 1) Transformer 12-0V
- 2) Diode IN4007 x5
- 3) LM7812 x1 stabilizer
- 4) Relay 12V x1
- 5) BC548 Transistor x1
- 6) Electrolytic capacitor 1000uF x1
- 7) GSM Module: SIM 800 or SIM 900 model
- 8) 330 Ohm Resistor x2
- 9) LEDs Red / Green x1
- 10) Arduino Uno or Arduino nano or Arduino Mega



Figure 11. Functional system

### CONCLUSION

Remote monitoring and management systems based on GPRS, UMTS and EDGE technologies have largely shifted to the boundaries of the meaning of the concept of the remote control with highspeed transmission of large amounts of data, the system also features stability connectivity and the use of existing infrastructure resources. It is very characteristic that reduces financial start-up, as well as the cost of maintaining the system, as well as for use GSM networks are minimal. In addition to all above,

the security of the system is an excellent data transfer as well as management. Multiple log encryption and encryption are used, so access is allowed exclusively for authorized users. On the end, we have to say that the solution described is new in our market and it is completely the result of the work of local experts. Advantages of such a system were observed by many utility companies, and this was implemented in several water supply systems in the Republic of North Macedonia.

### REFERENCES

- Emil Prpić (2017). Mobile communication.  
<http://www.angelfire.com/ne/svetac/diplomski.htm>  
[http://en.wikipedia.org/wiki/General\\_Packet\\_Radio\\_Service](http://en.wikipedia.org/wiki/General_Packet_Radio_Service) - Wikipedia - GPRS  
[http://en.wikipedia.org/wiki/Universal\\_Mobile\\_Telecommunications\\_System](http://en.wikipedia.org/wiki/Universal_Mobile_Telecommunications_System) - Wikipedia - UMTS  
<http://en.wikipedia.org/wiki/Arduino> - Wikipedia - Arduino  
<http://www.arduino.cc/> - Arduino  
<http://www.instructables.com/id/ArduinoPhone/>  
<http://yexiaobo-seeedstudio.github.io/ArduinoPhone/>  
<http://blog.arduino.cc/2013/08/12/diy-cellphone/>  
<http://arduino.cc/en/Main/arduinoBoardUno>  
[http://www.seeedstudio.com/wiki/index.php?title=GPRS\\_Shield\\_v0.9b](http://www.seeedstudio.com/wiki/index.php?title=GPRS_Shield_v0.9b)  
<http://www.robotshop.com/media/files/PDF/gprs-shield-sld33149p.pdf>. GSM/GPRS  
[http://www.geeetech.com/wiki/index.php/Arduino\\_GPRS\\_Shield](http://www.geeetech.com/wiki/index.php/Arduino_GPRS_Shield)  
[http://www.electfreaks.com/wiki/index.php?title=EFCOM\\_GPRS/GSM\\_Shield](http://www.electfreaks.com/wiki/index.php?title=EFCOM_GPRS/GSM_Shield)  
[http://electfreaks.com/store/download/datasheet/rf/SIM900/SIM900\\_AT%20Command%20Manual\\_V1.03.pdf](http://electfreaks.com/store/download/datasheet/rf/SIM900/SIM900_AT%20Command%20Manual_V1.03.pdf). GSM/GPRS

## ДАЛЕЧИНСКО УПРАВУВАЊЕ СО СИСТЕМИ ЗА НАВОДНУВАЊЕ НА БУНАРИ ЗА СОЛАРНА ЕНЕРГИЈА ВО ЛОЗАРСТВОТО

Димитар Ангелков<sup>1\*</sup>, Виолета Димовска<sup>2</sup>, Ефремчо Николов<sup>3</sup>, Фиданка Илиева<sup>2</sup>

<sup>1</sup>СОУ „Киро Спанџов-Брќо“, Шишка б.б., Кавадарци, РСМ

<sup>2</sup>Земјоделски факултет, Универзитет „Гоце Делчев“, Крсте Мисирков б.б., Штип, РСМ

<sup>3</sup>Земјоделско-шумарско училиште „Горче Петров“, Шишка б.б., Кавадарци, РСМ

\*Контакт автор: [dimitrijaa@yahoo.com](mailto:dimitrijaa@yahoo.com)

### Резиме

Одгледувањето на виновата лоза од страна на човекот датира со векови или илјадници години, но, сепак, прогресот на знаењето во одгледувањето на виновата лоза порасна енорно во последните педесетина години.

Масовното производство со високородни сорти од грозје, вински и трпезни, густото садење, употребата на ѓубривата, примената на наводнувањето, добивањето на високи приноси, придонесоа за интензивирање на условите за развој на болестите, штетните инсекти и развојот на плевелите.

За таа цел мобилните соларни агрегати денес се многу погодни за примена во земјоделството (лозарството, овоштарството, полјоделството, градинарството, сточарството и др.), поготово на оние локации на коишто не е можна достапност од мрежно напојување, но и во случаи каде што имаме органско производство на храна бидејќи ги задоволуваат и најстрогите еколошки стандарди.

Во поново време денес во светот се работи на интензивен развој и примена на мобилни соларни генератори коишто во себе содржат системи за следење на сонцето и истите наоѓаат примена во земјоделството.

**Клучни зборови:** лозарство, далечинско управување, системи за наводнување.