

**GOCE DELCEV UNIVERSITY, SHTIP, NORTH MACEDONIA  
FACULTY OF ELECTRICAL ENGINEERING**

**ETIMA 2021**  
**FIRST INTERNATIONAL CONFERENCE**  
**19-21 OCTOBER, 2021**

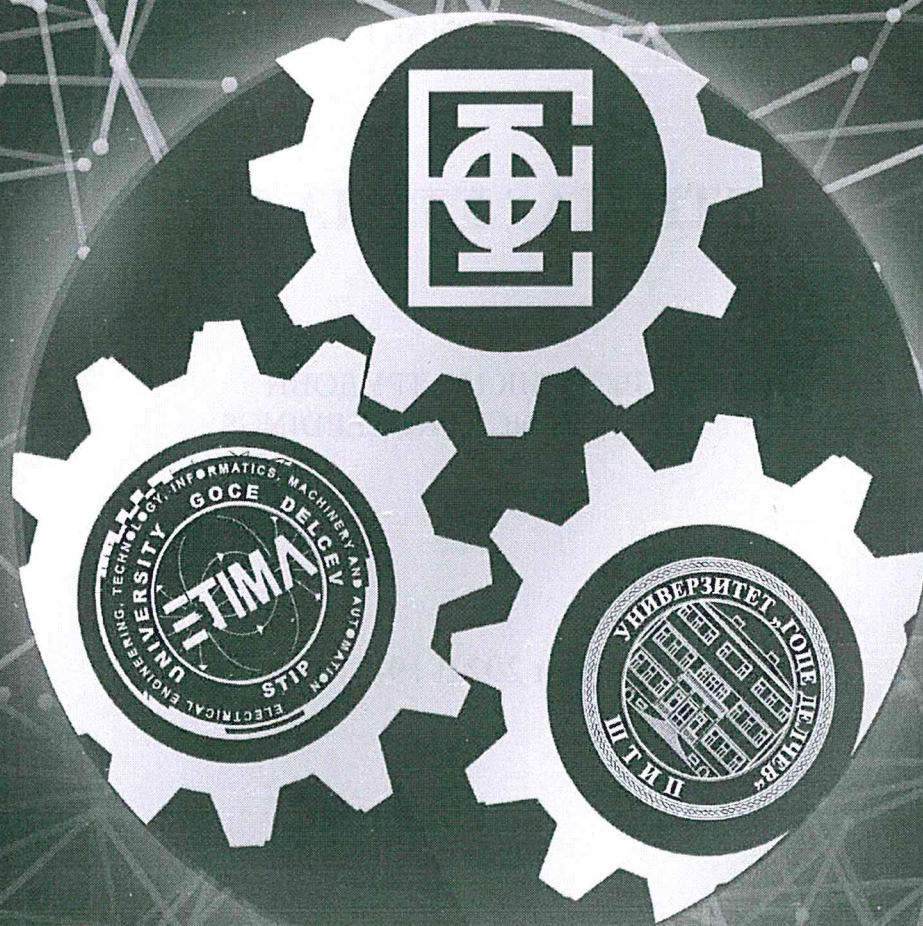

**TECHNICAL SCIENCES APPLIED IN ECONOMY,  
EDUCATION AND INDUSTRY**

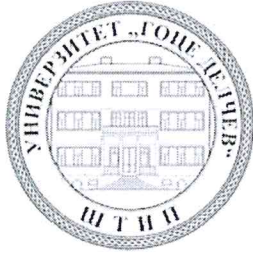

---

УНИВЕРЗИТЕТ „ГОЦЕ ДЕЛЧЕВ” - ШТИП  
ЕЛЕКТРОТЕХНИЧКИ ФАКУЛТЕТ

UNIVERSITY „GOCE DELCHEV” - SH TIP  
FACULTY OF ELECTRICAL ENGINEERING

ПРВА МЕЃУНАРОДНА КОНФЕРЕНЦИЈА  
FIRST INTERNATIONAL CONFERENCE

**ETIMA / ETIMA 2021**

ЗБОРНИК НА ТРУДОВИ  
CONFERENCE PROCEEDINGS

19-21 Октомври 2021 | 19-21 October 2021

**Главен и одговорен уредник / Editor in Chief**

Проф.д-р Сашо Гелев  
Prof.d-r Saso Gelev

**Јазично уредување / Language Editor**

Весна Ристова (Македонски) / Vesna Ristova (Macedonian)

**Техничко уредување / Technical Editing**

Доц.д-р Далибор Серафимовски / d-r Dalibor Serafimovski

**Издавач / Publisher**

Универзитет „Гоце Делчев“ - Штип / University Goce Delchev - Stip  
Електротехнички факултет / Faculty of Electrical Engineering

**Адреса на организационен комитет / Adress of the organizational committee**

Универзитет „Гоце Делчев“ – Штип / University Goce Delchev - Stip  
Електротехнички факултет / Faculty of Electrical Engineering  
Адреса: ул. „Крсте Мисирков“ бр. 10-А / Adress: Krste Misirkov, 10 - A  
Пош. фах 201, Штип - 2000, С.Македонија / PO BOX 201, Stip 2000, North Macedonia  
**E-mail: [conf.etf@ugd.edu.mk](mailto:conf.etf@ugd.edu.mk)**

CIP - Каталогизација во публикација  
Национална и универзитетска библиотека "Св. Климент Охридски", Скопје

62-049.8(062)  
004-049.8(062)

МЕЃУНАРОДНА конференција ЕТИМА (1 ; 2021)  
Зборник на трудови [Електронски извор] / Прва меѓународна  
конференција ЕТИМА 2021, 19-21 Октомври 2021 = Conference proceedings /  
First international conferece ETIMA 2021, 19-21 October 2021 ; [главен и  
одговорен уредник Сашо Гелев]. - Штип: Универзитет "Гоце Делчев",  
Електротехнички факултет = Shtip: University "Goce Delchev", Faculty of  
Electrical Engineering, 2021

Начин на пристапување (URL): <https://js.ugd.edu.mk/index.php/etima>. -  
Текст во PDF формат, содржи 358 стр.илустр. - Наслов преземен од  
екранот. - Опис на изворот на ден 15.10.2021. - Трудови на мак. и англ.  
јазик. - Библиографија коп трудовите

ISBN 978-608-244-823-7

1. Напор. ств. насл.

а) Електротехника -- Примена -- Собири б) Машинство -- Примена -- Собири  
в) Автоматика -- Примена -- Собири г) Информатика -- Примена -- Собири

COBISS.MK-ID 55209989



Прва меѓународна конференција ЕТИМА  
19-21 Октомври 2021  
First International Conference ETIMA  
19-21 October 2021

**ОРГАНИЗАЦИОНЕН ОДБОР  
ORGANIZING COMMITTEE**

**Василија Шарац / Vasilija Sarac**

Електротехнички факултет,  
Универзитет „Гоце Делчев“ - Штип, Северна Македонија  
Faculty of Electrical Engineering,  
Goce Delchev University - Stip, North Macedonia

**Сашо Гелев / Saso Gelev**

Електротехнички факултет,  
Универзитет „Гоце Делчев“ - Штип, Северна Македонија  
Faculty of Electrical Engineering,  
Goce Delchev University - Stip, North Macedonia

**Тодор Чекеровски / Todor Cekerovski**

Електротехнички факултет,  
Универзитет „Гоце Делчев“ - Штип, Северна Македонија  
Faculty of Electrical Engineering,  
Goce Delchev University - Stip, North Macedonia

**Далибор Серафимовски / Dalibor Serafimovski**

Електротехнички факултет,  
Универзитет „Гоце Делчев“ - Штип, Северна Македонија  
Faculty of Electrical Engineering,  
Goce Delchev University - Stip, North Macedonia

**Маја Кукушева Панева / Maја Kukuseva Paneva**

Електротехнички факултет,  
Универзитет „Гоце Делчев“ - Штип, Северна Македонија  
Faculty of Electrical Engineering,  
Goce Delchev University - Stip, North Macedonia

**Билјана Читкушева Димитровска / Bilјana Citkuseva Dimitrovska**

Електротехнички факултет,  
Универзитет „Гоце Делчев“ - Штип, Северна Македонија  
Faculty of Electrical Engineering,  
Goce Delchev University - Stip, North Macedonia

**Весна Конзулова / Vesna Konzulova**

Електротехнички факултет,  
Универзитет „Гоце Делчев“ - Штип, Северна Македонија  
Faculty of Electrical Engineering,  
Goce Delchev University - Stip, North Macedonia



Прва меѓународна конференција ЕТИМА  
19-21 Октомври 2021  
First International Conference ETIMA  
19-21 October 2021

**ПРОГРАМСКИ И НАУЧЕН ОДБОР  
SCIENTIFIC COMMITTEE**

**Со Ногучи / So Noguchi**

Висока школа за информатички науки и технологии  
Универзитет Хокаидо, Јапонија  
Graduate School of Information Science and Technology  
Hokkaido University, Japan

**Диониз Гашипаровски / Dionýz Gašparovský**

Факултет за електротехника и информациона технологија,  
Словачки Технички Универзитет во Братислава, Словачка  
Faculty of Electrical Engineering and Information Technology  
Slovak Technical University in Bratislava, Slovakia

**Антон Белан / Anton Belán**

Факултет за електротехника и информациона технологија,  
Словачки Технички Универзитет во Братислава, Словачка  
Faculty of Electrical Engineering and Information Technology  
Slovak Technical University in Bratislava, Slovakia

**Георги Иванов Георгиев / Georgi Ivanov Georgiev,**

Технички Универзитет во Габрово, Бугарија  
Technical University in Gabrovo, Bulgaria

**Ивелина Стефанова Балабанова / Ivelina Stefanova Balabanova,**

Технички Универзитет во Габрово, Бугарија  
Technical University in Gabrovo, Bulgaria

**Бојан Димитров Каранев / Boyan Dimitrov Karanев**

Технички Универзитет во Габрово, Бугарија  
Technical University in Gabrovo, Bulgaria

**Сашо Гелев / Saso Gelev**

Електротехнички факултет,  
Универзитет „Гоце Делчев“ - Штип, Северна Македонија  
Faculty of Electrical Engineering,  
Goce Delchev University - Stip, North Macedonia

**Влатко Чингоски / Vlatko Cingoski**  
Електротехнички факултет,  
Универзитет „Гоце Делчев” - Штип, Северна Македонија  
Faculty of Electrical Engineering,  
Goce Delchev University - Stip, North Macedonia

**Божо Крстајиќ / Bozo Krstajic**  
Електротехнички факултет  
Универзитет во Црна Гора, Црна Гора  
Faculty of Electrical Engineering,  
University in Montenegro, Montenegro

**Милован Радуловиќ / Milovan Radulovic**  
Електротехнички факултет  
Универзитет во Црна Гора, Црна Гора  
Faculty of Electrical Engineering,  
University in Montenegro, Montenegro

**Гоце Стефанов / Goce Stefanov**  
Електротехнички факултет,  
Универзитет „Гоце Делчев” - Штип, Северна Македонија  
Faculty of Electrical Engineering,  
Goce Delchev University - Stip, North Macedonia

**Мирјана Периќ / Mirjana Peric**  
Електронски факултет  
Универзитет во Ниш, Србија  
Faculty of Electronic Engineerig,  
University of Nis, Serbia

**Ана Вучковиќ / Ana Vuckovic**  
Електронски факултет  
Универзитет во Ниш, Србија  
Faculty of Electronic Engineerig,  
University of Nis, Serbia

**Тодор Чекеровски / Todor Cekerovski**  
Електротехнички факултет,  
Универзитет „Гоце Делчев” - Штип, Северна Македонија  
Faculty of Electrical Engineering,  
Goce Delchev University - Stip, North Macedonia

**Далибор Серафимовски / Dalibor Serafimovski**  
Електротехнички факултет,  
Универзитет „Гоце Делчев” - Штип, Северна Македонија  
Faculty of Electrical Engineering,  
Goce Delchev University - Stip, North Macedonia

**Мирослава Фаркаш Смиткова / Miroslava Farkas Smitková**

Факултет за електротехника и информациони технологии  
Словачки Технички Универзитет во Братислава, Словачка  
Faculty of Electrical Engineering and Information Technology  
Slovak Technical University in Bratislava, Slovakia

**Петер Јанига / Peter Janiga**

Факултет за електротехника и информациони технологии  
Словачки Технички Универзитет во Братислава, Словачка  
Faculty of Electrical Engineering and Information Technology  
Slovak Technical University in Bratislava, Slovakia

**Јана Радичова / Jana Raditschová,**

Факултет за електротехника и информациони технологии  
Словачки Технички Универзитет во Братислава, Словачка  
Faculty of Electrical Engineering and Information Technology  
Slovak Technical University in Bratislava, Slovakia

**Драган Миновски / Dragan Minovski**

Електротехнички факултет,  
Универзитет „Гоце Делчев” - Штип, Северна Македонија  
Faculty of Electrical Engineering,  
Goce Delchev University - Stip, North Macedonia

**Василија Шарац / Vasilija Sarac**

Електротехнички факултет,  
Универзитет „Гоце Делчев” - Штип, Северна Македонија  
Faculty of Electrical Engineering,  
Goce Delchev University - Stip, North Macedonia

**Александар Туцаров / Aleksandar Tudzarov**

Електротехнички факултет,  
Универзитет „Гоце Делчев” - Штип, Северна Македонија  
Faculty of Electrical Engineering,  
Goce Delchev University - Stip, North Macedonia

**Владимир Талевски / Vladimir Talevski**

Електротехнички факултет,  
Универзитет „Гоце Делчев” - Штип, Северна Македонија  
Faculty of Electrical Engineering,  
Goce Delchev University - Stip, North Macedonia



## Прва меѓународна конференција ЕТИМА First International Conference ETIMA

---

### **PREFACE**

The Faculty of Electrical Engineering at University Goce Delcev (UGD), has organized the International Conference *Electrical Engineering, Informatics, Machinery and Automation - Technical Sciences applied in Economy, Education and Industry-ETIMA*.

ETIMA has a goal to gather the scientists, professors, experts and professionals from the field of technical sciences in one place as a forum for exchange of ideas, to strengthen the multidisciplinary research and cooperation and to promote the achievements of technology and its impact on every aspect of living. We hope that this conference will continue to be a venue for presenting the latest research results and developments on the field of technology.

Conference ETIMA was held as online conference where contributed more than sixty colleagues, from six different countries with forty papers.

We would like to express our gratitude to all the colleagues, who contributed to the success of ETIMA '21 by presenting the results of their current research activities and by launching the new ideas through many fruitful discussions.

We invite you and your colleagues also to attend ETIMA Conference in the future. One should believe that next time we will have opportunity to meet each other and exchange ideas, scientific knowledge and useful information in direct contact, as well as to enjoy the social events together.

*The Organizing Committee of the Conference*

### **ПРЕДГОВОР**

Меѓународната конференција *Електротехника, Технологија, Информатика, Машињство и Автоматика-технички науки во служба на економија, образование и индустрија-ЕТИМА* е организирана од страна на Електротехничкиот факултет при Универзитетот Гоце Делчев.

ЕТИМА има за цел да ги собере на едно место научниците, професорите, експертите и професионалците од полето на техничките науки и да представува форум за размена на идеи, да го зајканува мултидисциплинарното истражување и соработка и да ги промовира технолошките достигнувања и нивното влијание врз секој аспект од живеењето. Се надеваме дека оваа конференција ќе продолжи да биде настан на кој ќе се презентираат најновите резултати од истражувањата и развојот на полето на технологијата.

Конференцијата ЕТИМА се одржа online и на неа дадоа свој допринос повеќе од шеесет автори од шест различни земји со четириесет труда.

Сакаме да ја искажеме нашата благодарност до сите колеги кои допринесоа за успехот на ЕТИМА '21 со презентирање на резултати од нивните тековни истражувања и со лансирање на нови идеи преку многу плодни дискусии.

Ве покануваме Вие и Вашите колеги да земете учество на ЕТИМА и во иднина. Веруваме дека следниот пат ќе имаме можност да се сретнеме, да размениме идеи, знаење и корисни информации во директен контакт, но исто така да уживаме заедно и во друштвените настани.

*Организационен одбор на конференцијата*



## Содржина / Table of Contents

ASSESSING DIGITAL SKILLS AND COMPETENCIES OF PUBLIC ADMINISTRATION AND DEFINING THEIR PROFICIENCY LEVEL.....	12
PWM OPERATION OF SYNCHRONOUS PERMANENT MAGNET MOTOR .....	21
SPEED REGULATION OF INDUCTION MOTOR WITH PWM INVERTER.....	30
WI-FI SMART POWER METER .....	42
RF SENSOR SMART NETWORK.....	50
FREQUENCY SINUS SOURCE.....	62
MEASUREMENT ON COMPENSATION CAPACITANCE IN INDUCTIVE NETWORK BY MICROCONTROLLER.....	70
ИЗРАБОТКА НА ВЕШТ НАОД И МИСЛЕЊЕ ОД ОБЛАСТА НА ЕЛЕКТРОТЕХНИЧКИТЕ НАУКИ.....	79
SIMULATION OF AN INDUSTRIAL ROBOT WITH THE HELP OF THE MATLAB SOFTWARE PACKAGE.....	86
BATTERY ENERGY STORAGE SYSTEMS AND TECHNOLOGIES:A REVIEW ..	95
POWER-TO-X TECHNOLOGIES.....	105
NEW INNOVATIVE TOURISM PRODUCT FOR REANIMATING RURAL AREAS .....	115
PROPOSED MODEL FOR BETTER ENGLISH LANGUAGE ACQUISITION, BASED ON WEARABLE DEVICES.....	123
OPEN SOURCE LEARNING PLATFORM – MOODLE .....	132
СПОРЕДБЕНА ТЕХНО-ЕКОНОМСКА АНАЛИЗА ПОМЕЃУ ТЕРМИЧКИ ИЗОЛИРАН И ТЕРМИЧКИ НЕИЗОЛИРАН СТАЊБЕН ОБЈЕКТ .....	139
COMPARISON OF PERT AND MONTE CARLO SIMULATION .....	149
E-LEARNING – CYBER SECURITY CHALLENGES AND PROTECTION MECHANISMS .....	156
SECURITY AND PRIVACY WITH E-LEARNING SOFTWARE .....	164
ROOTKITS – CYBER SECURITY CHALLENGES AND MECHANISMS FOR PROTECTION .....	174
TOOLS AND TECHNIQUES FOR MITIGATION AND PROTECTION AGAINST SQL INJECTION ATTACKS .....	182
INFLUENCE OF ROTATION ANGLE OF LUMINAIRES WITH ASYMMETRICAL LUMINOUS INTENSITY DISTRIBUTION CURVE ON CALCULATED PHOTOMETRIC PARAMETERS.....	189
PHOTOMETRIC PARAMETERS OF LED LUMINAIRES WITH SWITCHABLE CORRELATED COLOUR TEMPERATURE .....	197
ENERGY-EFFICIENT STREET LIGHTING SYSTEM OF THE CITY OF SHTIP USING SOLAR ENERGY AND LED TECHNOLOGY.....	204
NANOTECHNOLOGY–BASED BIOSENSORS IN DRUG DELIVERY SYSTEMS: A REVIEW.....	212

<b>IOT SYSTEM FOR SHORT-CIRCUIT DETECTION OF DC MOTOR AT EKG-15 EXCAVATOR .....</b>	<b>222</b>
<b>DESIGN OF A PHOTOVOLTAIC POWER PLANT .....</b>	<b>231</b>
<b>DEVELOPMENT OF COMPUTER SOFTWARE FOR CREATING CHOREOGRAPHY .....</b>	<b>241</b>
<b>AUTOMATED SYSTEM FOR SMART METER TESTING.....</b>	<b>249</b>
<b>INFLUENCE DIMING OF LED LAMPS TO ELECTRICAL PARAMETERS .....</b>	<b>255</b>
<b>INRUSH CURRENT OF LAMP.....</b>	<b>261</b>
<b>COMPLEX EVALUATION MODEL OF A SMALL-SCALE PHOTOVOLTAIC INSTALLATION PROFITABILITY .....</b>	<b>269</b>
<b>IMPACT OF FAULTS IN TRANSMISSION AND DISTRIBUTION NETWORK ON VOLTAGE SAGS .....</b>	<b>278</b>
<b>ON APPLICABILITY OF BLACK-SCHOLES MODEL TO MSE .....</b>	<b>290</b>
<b>ACOUSTIC SIGNAL DENOISING BASED ON ROBUST PRINCIPAL COMPONENT ANALYSIS .....</b>	<b>300</b>
<b>INVESTIGATION OF EFFICIENCY ASPECTS IN 3×3 PHOTOVOLTAIC PLANT USING MODEL OF SHADING .....</b>	<b>309</b>
<b>PROGRESS OF NO-INSULATION HTS MAGNET DEVELOPMENT TOWARDS ULTRA-HIGH MAGNETIC FIELD GENERATION.....</b>	<b>319</b>
<b>GRID-CONNECTED HYBRID PV SYSTEM WITH BATTERY STORAGE.....</b>	<b>326</b>
<b>INVESTIGATION ON STABILITY OF PANCAKE COILS WOUND WITH BUNDLED MULTIPLE REBCO CONDUCTORS .....</b>	<b>336</b>
<b>ON-LINE МУЛТИМЕДИСКИ ОБРАЗОВНИ КАРТИЧКИ .....</b>	<b>343</b>
<b>АЛГОРИТАМОТ „ВЕШТАЧКА КОЛОНИЈА НА ПЧЕЛИ“ .....</b>	<b>352</b>



## DESIGN OF A PHOTOVOLTAIC POWER PLANT

**Sara Aneva**

Faculty of Electrical Engineering  
Goce Delcev University,  
Stip, R.N. Macedonia  
Sara.20551@student.ugd.edu.mk

**Todor Cekerovski**

Faculty of Electrical  
Engineering  
Goce Delcev University, Stip,  
R.N. Macedonia  
todor.cekerovski@ugd.edu.mk

**Marija Cekerovska**

Faculty of Mechanical  
Engineering  
Goce Delcev University,  
Stip, R.N. Macedonia  
marija.cekerovska@ugd.edu.mk

### Abstract

*The largest source of renewable energy is the Sun. The energy from the Sun, called solar energy, is free, safe and least harmful to the environment. Solar energy is converted into electricity by devices based on semiconductor materials, called photovoltaics. If the production of electricity from fossil fuels is replaced by the production of electricity from sunlight there will be much lower emissions of carbon dioxide. This paper analyzes the location, solar radiation and network connection for the provided location for the photovoltaic power plant. For collecting data on solar radiation, satellite data at a specific location were used. Based on these analyzes, the technical characteristics of the photovoltaic power plant with a total installed power of 201.6 kW are dimensioned and selected. The principal scheme of the photovoltaic power plant and the scheme of the AC Junction box are drawn in the software package Edraw max. Finally, the economic and financial profitability of the photovoltaic power plant is reviewed and proven.*

**Key words:** solar energy, solar radiation, network connection, Photovoltaic Power Plant, AC Junction box, economic and financial profitability.

### Introduction

One of the biggest problems facing the world today is the increase in electricity consumption globally and the pollution of the environment from burning fossil fuels (coal, oil, natural gas, etc.) for electricity production. Climate change is now more pronounced than ever before. Temperatures are rising globally due to greenhouse gases trapping more heat in the atmosphere. As a result of the increased temperature, fires occur and the ice melts. It is a well-known fact that many prehistoric viruses are hidden in the frozen parts of our planet, which will be reactivated if the ice melts. The threat is clear, and one of the main causes of climate change is the burning of fossil fuels to generate electricity. Combustion of fossil fuels releases carbon dioxide into the air, resulting in global warming. Increasing the production of electricity from renewable sources, such as solar energy, wind energy, hydroelectric energy, etc. will significantly reduce the effects of climate change and will help save our planet.

The prices of solar technology are currently much lower than before, and the implementation of solar power plants and systems is very simple. The Republic of North Macedonia is located in a very good geographical location, where solar radiation is large and suitable for installation of solar (photovoltaic - PV) systems and power plants and is one of the countries with the

highest solar radiation in Europe, but unfortunately it's not one of the countries that use solar energy the most. However, the production of solar energy does not pollute the environment, so we can conclude that, at the moment, the installation of photovoltaic systems for the production of electricity is the best choice. Due to this, in this paper researches have been made for installation of a photovoltaic power plant in the Republic of North Macedonia, in the city of Shtip. Based on the research, a 201.6 kW Photovoltaic Power Plant has been designed.

## 7. Literature review

When designing a photovoltaic power plant, several steps should be observed, given below in chronological order:

- Location selection;
- Determination of solar radiation and
- Network connection.

If the selected location proves to be good for installing a photovoltaic power plant (good solar radiation, has a transformer station or has the opportunity to build a new one, enough space, etc.), the following activities to be undertaken are:

- Selection of solar panels;
- Selection of connectors;
- Inverter selection and
- Selection of cables.

Once the technical characteristics of the power plant have been selected, the next step is to design the AC and DC junction box and finally make a financial analysis of the photovoltaic power plant.

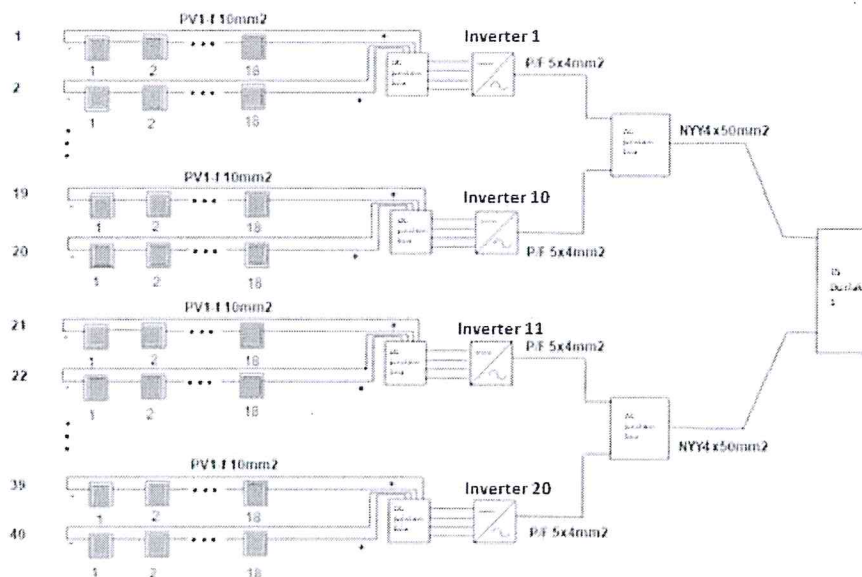

**Fig. 1 Principle scheme of the proposed PV power plant**

Source: Author made this scheme in the software package Edraw max

The photovoltaic power plant designed in this paper has a total installed power of 201.6kW, and its principle scheme is shown in figure 1. This power plant consists of 40 PV arrays, each with 18 solar panels. Solar panels are interconnected by solar cables. Each of the two PV arrays is connected in parallel to a DC junction box. DC junction boxes have four 10A fuses and are connected to an inverter. The power plant has 20 inverters. 10 inverters are connected to one AC junction box and the other 10 inverters are connected to the other AC junction box. The two AC junction boxes are connected to the existing transformer station at the selected location and the produced electricity goes to the grid.

The total average annual electricity production from this power plant can be calculated as follows:

$$E_{total} = I_{daily,avg} \cdot P_{PV,total} \cdot 365 = 3.6 \cdot 201.6 \cdot 365 = 264902.4kWh/year \quad (1.1)$$

Where:

$I_{daily,avg}$  - daily average radiation in the city of Shtip;

$P_{PV,total}$  - total installed power of the photovoltaic power plant.

## 8. Location selection

The first step in designing a PV power plant is location selection. Choosing the right location is a key component to developing a sustainable photovoltaic project. The location selection process should take into account the constraints and the impact that the location will have on the price of the produced electricity. This means that the selected location should have an accessible area as much as will be needed for the implementation of the project, the solar radiation should be satisfactory, there should be no objects that will shade the modules, it should be easily accessible, there should be a transformer station nearby or to have a place for construction of a new transformer station, etc.

The selected location for the photovoltaic power plant in Stip is a place that is located near the neighborhood Sunny City. This location was chosen because it is located close to the transformer station Duzlak 1, so there will be no need to build a new transformer station. Another reason why this location is suitable is that there are no buildings that would do shading. This place has a lot of space, but most of it has trees. To build this power plant on that place, the trees will have to be cut down. Due to this, the location of the power plant is subject to change. The site for the power plant is state-owned and its use will require a long-term lease or purchase agreement.

## 9. Determination of solar radiation

In order for a photovoltaic project to be approved, we need to have data on solar radiation at the selected location. The solar resource expected during the entire service life of the photovoltaic power plant is estimated by analyzing the historical data on solar resources for the location. The total annual solar radiation in R.N. Macedonia varies from a minimum of 1250  $kWh/m^2$  in the north to a maximum of 1530  $kWh/m^2$  in the southwest. The area of the municipality of Shtip is characterized with increased duration of the solar radiation. On average, there are 2,370 hours of solar radiation per year, or an average of 6.5 hours per day. The maximum is in July and the minimum in December. The average daily radiation in Shtip is 3.6  $kWh/m^2$ . In the region of Shtip there is a good potential for utilization of the solar energy which can be seen from the map of solar resources of R.N. Macedonia presented in figure 2.

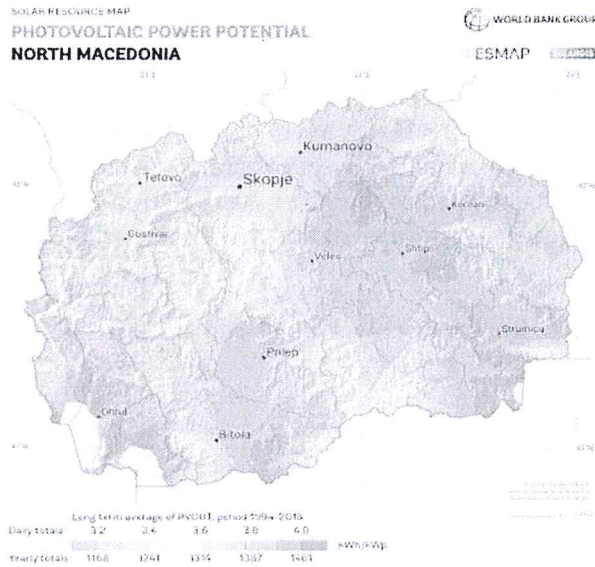

**Fig. 2 Map of solar resources of R.N. Macedonia**  
Source: [www.solargis.com](http://www.solargis.com)

### 10. Network connection

A grid connection with sufficient capacity is required to enable energy exports. The viability of the network connection depends on factors such as capacity, proximity, order, network stability and network availability.

This power plant will be connected to the transformer station Duzlak 1 (10 / 0.4 kV).

### 11. Solar panels

The solar panels that we will use for this power plant are from the company Pikcell Group, polycrystalline, type PIK280P (60), with installed power of 280 W. The company Pikcell Group is the first and only company in R.N. Macedonia that produces solar panels.

**Table 1. Electrical characteristics of solar panel PIK280P (60)**

ELECTRICAL CHARACTERISTICS	
STC (radiation: $G = 1000W / m^2$ , module temperature: $T = 25^{\circ}C$ , air mass: $AM = 1.5$ )	
Rated power ( $P_{rated}$ )	280 W
Short circuit current ( $I_{sc}$ )	9.45 A
Open circuit voltage ( $U_{oc}$ )	38.40 V
Current at MPP ( $I_{MPP}$ )	8.85 A
Voltage at MPP ( $U_{MPP}$ )	31.61 V
Solar panel efficiency	18.66 %

Source: PiKCELL Group LTD Skopje

**Table 2. Mechanical characteristics of solar panel PIK280P(60)**

MECHANICAL CHARACTERISTICS	
Dimensions	1640mm x 990mm x 40mm
Solar cells	60 polycrystalline
Weight	17.2 kg
Junction box/ Connectors	5 bypass diodes / MC4 compatible
Glass	3.2 mm antireflective

Source: PiKCELL Group LTD Skopje

The solar panels will be placed at an angle of 30° to the south. This angle is the angle at which the solar panels will produce maximum electricity at the selected location.

The total installed power of the photovoltaic power plant is 201.6 kW. Through the data on the installed power of the power plant and the power of the solar panels we can calculate the number of panels that we will need through the following equation:

$$N_{solarpanel} = \frac{P_{vk}}{P_{solarpanel}} \quad (5.1)$$

Where:

$P_{vk}$  - total installed power of the photovoltaic power plant;

$P_{solarpanel}$  - rated power of one panel.

$$N_{solarpanel} = \frac{201.6kW}{280W} = \frac{201600W}{280W} = 720 \quad (5.2)$$

The total area occupied by all the panels is obtained through the following equation:

$$A = N_{solarpanel} \cdot A_{solarpanel} = 720 \cdot 1.9305m^2 = 1389.96m^2 \quad (5.3)$$

Where:

$A_{solarpanel}$  - area of one solar panel.<sup>11</sup>

## 12. Connectors

According to the specifications of the solar panels, a compatible connector for those panels is the MC4 connector, type SY-CC4G for solar cables.

## 13. Inverter

Inverters are a particularly important part of the sizing of photovoltaic systems. Although the main function of the inverter is to convert DC energy to AC, its role is much larger. Inverters enable system monitoring for designers and owners, because they show how much electricity the system produces. There are different types of inverters and they differ according to how

<sup>11</sup> The dimensions of the solar panel are given by the manufacturer.

they are connected to the system. For this PV power plant we will use string inverters. We will have a total of 20 inverters, and on each inverter will be connected two PV arrays.

The chosen inverter for this PV power plant is three-phase, from the manufacturer Steca, type StecaGrid 10000 + 3ph.

**Table 3. Input characteristics of the inverter StecaGrid 10000 +3ph**

DC input side (PV generator connection)	
Maximum input voltage ( $V_{max}$ )	845 V
Minimum input voltage ( $V_{DC,min}$ )	350 V
Rated input voltage ( $V_{DC,rated}$ )	600 V
Maximum input current ( $I_{DC,max}$ )	32 A
Rated input current ( $I_{DC,rated}$ )	17.3 A
Maximum input power at maximum active output power ( $P_{DC,max}$ )	10 800 W

Source: StecaGrid

**Table 4. Output characteristics of the inverter StecaGrid 10000 +3ph**

AC output side (mains grid connection)	
Output voltage ( $V_{AC}$ )	320 V ... 480 V (The output voltage depends on the network of each country, in our country the EVN network operates at 380V)
Maximum output current ( $I_{AC,max}$ )	16 A
Rated output current ( $I_{AC,rated}$ )	14.3 A
Output power ( $P_{AC}$ )	10 000 W
Frequency	50 Hz
Grid type	$L_1 / L_2 / L_3 / N / PE$
Maximum efficiency ( $\eta_{max}$ )	96.3 %

Source: StecaGrid

#### Maximum number of modules in a PV array

$$\eta_{max} = \frac{V_{max(MPV)}}{V_{oc(module-10^{\circ}C)}} \quad (7.1)$$

Where:



$V_{\max(INV)}$  - maximum input voltage of the inverter;

$V_{oc(module=-10^{\circ}C)}$  - open circuit voltage at  $-10^{\circ}C$ .

$$\eta_{\max} = \frac{845}{42.43} = 19.9 \quad (7.2)$$

With this solution it was determined that the maximum number of modules in a PV array is 19.

#### Minimum number of modules in a PV array

$$\eta_{\min} = \frac{V_{MPP(INV \min)}}{V_{MPP(module 70^{\circ}C)}} \quad (7.3)$$

Where:

$V_{MPP(INV \min)}$  - minimum voltage of the inverter at MPP;

$V_{MPP(module 70^{\circ}C)}$  - minimum voltage of the module at MPP at a temperature of  $70^{\circ}C$ .

$$\eta_{\min} = \frac{350}{27.34} = 12.8 \quad (7.4)$$

The number of modules in a PV array should range between the borders of maximum number of modules in a PV array and the minimum number of modules in a PV array.

$$\eta_{\min} < \eta < \eta_{\max} \quad (7.5)$$

$$12.8 < 18 < 19.9$$

#### 14. Cables

Cables can be divided into solar cables and non-solar (standard cables). Solar cables connect the modules to the junction box or directly to the inverter. Standard cables are used on the AC side.

#### 15. DC junction box

The two PV arrays are connected in parallel with a DC junction box. 4 cables from both arrays of solar panels (2- and 2+) are connected to this junction box. Hence, in the DC junction box we will have 4 fuses, one for each cable. These fuses will be 10 A because the current in each of the cables is 8.85A. Fuses should have either the same or greater current than the current in the cables (equation (12)).

The current of the DC junction box can be calculated by the following equation:

$$I = I_{MPP} \cdot N_{string} \quad (9.1)$$

$I_{MPP}$  - PV array current at MPP;

$N_{string}$  - number of PV arrays at MPP;

$$I = 8.85 \cdot 2 = 17.7 A \quad (9.2)$$

$$I_{\text{cable}} \leq I \quad (9.3)$$

$$8.85 A \leq 10 A$$

### 16. AC junction box

We will use two AC junction boxes for this power plant. The first 10 inverters will be connected to the first AC junction box, and the second 10 inverters will be connected to the second AC junction box. In one AC junction box we will have ten 22 A fuses for each cable of the 10 inverters, 3 main fuses of 220 A on the three main cables L1, L2 and L3, zero and ground - FeZn30x4mm strip. The fuses should have a current equal to or greater than the current in the cables, and from equation (13) we can see that this condition is met.

$$I_{\text{cable}} = I_{\text{MPP}} \cdot N_{\text{string}} = 8.85 \cdot 2 = 17.7 A \quad (10.1)$$

$$I = 22 A$$

$$17.7 A < 22 A \quad (10.2)$$

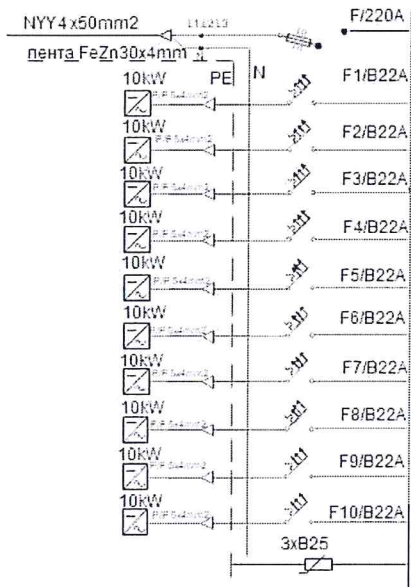

**Fig. 3 Single circuit diagram of AC junction box of the photovoltaic power plant**

Source: Author made this scheme in the software package Edraw Max.

### 17. Financial analysis

If it is assumed that a loan with a repayment period of 10 years with an interest rate of 6% is taken for this investment, then the annual repayment installments will be calculated with the following formula:

$$A = P \cdot GRF(i, n) \quad (11.1)$$

Where:

$A$  - annual repayment for taken loan;

$P$  - value of borrowed capital;

$i$  - interest rate (%);

$n$  - years of loan repayment;

$GRF(i, n)$  - return on equity factor.

$$GRF(i, n) = \frac{i(1+i)^n}{(1+i)^n - 1} = \frac{0.06(1.06)^{10}}{(1.06)^{10} - 1} = 0.13 \quad (11.2)$$

$$A = 100000 \cdot 0.13 = 13000 \text{ € / year} \quad (11.3)$$

**Table 5. Economic analysis of the designed power plant**

Economic analysis	
Equity	98085.49 €
Credit	100000 €
Interest rate	6%
Annual repayment	13000 €
Preferential tariff <sup>12</sup>	0.16 € / kWh

Source: author based on the actual policies of the banks in Republic of North Macedonia

The total profit from the photovoltaic power plant can be obtained by multiplying the total annual electricity production and the feed-in tariff (Table 10):

$$C_{vk} = E_{vk} \cdot FiT = 264902.4 \cdot 0.16 = 42384.384 \text{ € / year} \quad (11.4)$$

The time required for the return on investment will be given as a quotient of the total costs for the photovoltaic power plant and the annual earnings:

$$\frac{198085.49}{42384.38} = 4.67 \text{ years} \quad (11.5)$$

The investment for this photovoltaic power plant will return in 4.67 years, which means that the project for photovoltaic power plant of 201.6 kW in the city of Stip is profitable.

<sup>12</sup> This preferential tariff in R.N. Macedonia was valid until 2018. The preferential tariff has been used in the calculations because a premium tariff is now used.

## Conclusions

According to the financial analysis, the project for the photovoltaic power plant in Shtip is profitable and with its realization 112,647 kg / year of carbon dioxide emissions will be avoided. The construction of this photovoltaic power plant will open a new path to a cleaner environment and clean energy will be obtained.

The consciousness in the world is indisputably mature and the desire is clearly expressed, the ecological heritage that we will leave to future generations not to be less than what we have inherited. Saving on the costs of preserving the environment will significantly increase the costs that future generations will pay for its restoration.

## References

- [1] Jager, Klaus / Isabella, Olindo / H.M. Smets, Arno / A.C.M.M. van Swaaij, Rene / Zeman, Miro: *Solar Energy. Fundamentals, Technology, and Systems*. Delft University of Technology, 2014, pp. 326-327.
- [2] Mitnovski, Dragan: *Utilization of the potential from renewable energy sources in the Republic of Macedonia for electricity production. Master thesis*. Bitola, 2016, pp. 50-51.
- [3] *Training Manual for Engineers and Technicians - Design and Installation of Photovoltaic Systems*, Skopje 2019