

**GOCE DELCEV UNIVERSITY - STIP
FACULTY OF COMPUTER SCIENCE**

ISSN 2545-4803 on line

**BALKAN JOURNAL
OF APPLIED MATHEMATICS
AND INFORMATICS
(BJAMI)**



YEAR 2021

VOLUME IV, Number 1

GOCE DELCEV UNIVERSITY - STIP, REPUBLIC OF NORTH MACEDONIA
FACULTY OF COMPUTER SCIENCE

ISSN 2545-4803 on line

**BALKAN JOURNAL
OF APPLIED MATHEMATICS
AND INFORMATICS**



BALKAN JOURNAL
OF APPLIED MATHEMATICS AND INFORMATICS

(BJAMI)

AIMS AND SCOPE:

BJAMI publishes original research articles in the areas of applied mathematics and informatics.

Topics:

1. Computer science;
2. Computer and software engineering;
3. Information technology;
4. Computer security;
5. Electrical engineering;
6. Telecommunication;
7. Mathematics and its applications;
8. Articles of interdisciplinary of computer and information sciences with education, economics, environmental, health, and engineering.

Managing editor

Biljana Zlatanovska Ph.D.

Editor in chief

Zoran Zdravev Ph.D.

Lectoure

Snezana Kirova

Technical editor

Sanja Gacov

Address of the editorial office

Goce Delcev University – Štip
Faculty of philology
Krstе Misirkov 10-A
PO box 201, 2000 Štip,
Republic of North Macedonia

BALKAN JOURNAL
OF APPLIED MATHEMATICS AND INFORMATICS (BJAMI), Vol 3

ISSN 2545-4803 on line
Vol. 4, No. 1, Year 2021

EDITORIAL BOARD

- Adelina Plamenova Aleksieva-Petrova**, Technical University – Sofia,
Faculty of Computer Systems and Control, Sofia, Bulgaria
- Lyudmila Stoyanova**, Technical University - Sofia , Faculty of computer systems and control,
Department – Programming and computer technologies, Bulgaria
- Zlatko Georgiev Varbanov**, Department of Mathematics and Informatics,
Veliko Tarnovo University, Bulgaria
- Snezana Scepanovic**, Faculty for Information Technology,
University “Mediterranean”, Podgorica, Montenegro
- Daniela Veleva Minkovska**, Faculty of Computer Systems and Technologies,
Technical University, Sofia, Bulgaria
- Stefka Hristova Bouyuklieva**, Department of Algebra and Geometry,
Faculty of Mathematics and Informatics, Veliko Tarnovo University, Bulgaria
- Vesselin Velichkov**, University of Luxembourg, Faculty of Sciences,
Technology and Communication (FSTC), Luxembourg
- Isabel Maria Baltazar Simões de Carvalho**, Instituto Superior Técnico,
Technical University of Lisbon, Portugal
- Predrag S. Stanimirović**, University of Niš, Faculty of Sciences and Mathematics,
Department of Mathematics and Informatics, Niš, Serbia
- Shcherbacov Victor**, Institute of Mathematics and Computer Science,
Academy of Sciences of Moldova, Moldova
- Pedro Ricardo Morais Inácio**, Department of Computer Science,
Universidade da Beira Interior, Portugal
- Georgi Tuparov**, Technical University of Sofia Bulgaria
- Dijana Karuovic**, Tehnical Faculty “Mihajlo Pupin”, Zrenjanin, Serbia
- Ivanka Georgieva**, South-West University, Blagoevgrad, Bulgaria
- Georgi Stojanov**, Computer Science, Mathematics, and Environmental Science Department
The American University of Paris, France
- Iliya Guerguiev Bouyukliev**, Institute of Mathematics and Informatics,
Bulgarian Academy of Sciences, Bulgaria
- Riste Škrekovski**, FAMNIT, University of Primorska, Koper, Slovenia
- Stela Zhelezova**, Institute of Mathematics and Informatics, Bulgarian Academy of Sciences, Bulgaria
- Katerina Taskova**, Computational Biology and Data Mining Group,
Faculty of Biology, Johannes Gutenberg-Universität Mainz (JGU), Mainz, Germany.
- Dragana Glušac**, Tehnical Faculty “Mihajlo Pupin”, Zrenjanin, Serbia
- Cveta Martinovska-Bande**, Faculty of Computer Science, UGD, Republic of North Macedonia
- Blagoj Delipetrov**, Faculty of Computer Science, UGD, Republic of North Macedonia
- Zoran Zdravev**, Faculty of Computer Science, UGD, Republic of North Macedonia
- Aleksandra Mileva**, Faculty of Computer Science, UGD, Republic of North Macedonia
- Igor Stojanovik**, Faculty of Computer Science, UGD, Republic of North Macedonia
- Saso Koceski**, Faculty of Computer Science, UGD, Republic of North Macedonia
- Natasa Koceska**, Faculty of Computer Science, UGD, Republic of North Macedonia
- Aleksandar Krstev**, Faculty of Computer Science, UGD, Republic of North Macedonia
- Biljana Zlatanovska**, Faculty of Computer Science, UGD, Republic of North Macedonia
- Natasa Stojkovik**, Faculty of Computer Science, UGD, Republic of North Macedonia
- Done Stojanov**, Faculty of Computer Science, UGD, Republic of North Macedonia
- Limonka Koceva Lazarova**, Faculty of Computer Science, UGD, Republic of North Macedonia
- Tatjana Atanasova Pacemska**, Faculty of Computer Science, UGD, Republic of North Macedonia

CONTENT

Nenad Popovic, Saso Gelev METHODOLOGY FOR PREPARING EXPERTISE IN THE FIELD OF ELECTRICAL ENGINEERING	7
Goce Stefanov, Maja Kukuseva Paneva, Elena Stefanova Zafirova DESIGN OF AN INTELLIGENT WI-FI SENSOR NETWORK	17
Aleksandar Velinov, Saso Koceski, Natasa Koceska REVIEW OF THE USAGE OF TELEPRESENCE ROBOTS IN EDUCATION	27
Biljana Chitkusheva Dimitrovska, Roman Golubovski, Hristina Spasevska, Jasmina Veta Buralieva COMPUTATIONAL METHODOLOGY IN DETERMINING SHADING AMONG PHOTOVOLTAIC PANELS	41
Dijana Lapevska, Aleksandar Velinov, Zoran Zdravev ANALYSIS OF MOODLE ACTIVITIES BEFORE AND AFTER THE COVID-19 PANDEMIC – CASE STUDY AT GOCE DELCHEV UNIVERSITY	51
Olga Petan, Ljubinka Sandjakoska, And Atanas Hristov HOW DATA ENGINEERING AND BIG DATA ANALYTICS CAN CONTRIBUTE TO INTRODUCING INTELLIGENCE IN BUSINESS: A CASE STUDY	59

DESIGN OF AN INTELLIGENT WI-FI SENSOR NETWORK

Goce Stefanov, Maja Kukuseva Paneva, Elena Stefanova Zafirova

Abstract. In this paper intelligent Wi-Fi sensor network is designed. The main task is to visualize, store and distribute the signals from industrial sensors to an internet network. The solution is based on a microcomputer connection to the sensor network. In the paper, first, the characteristics of the used hardware are described, and the results of the experimental work of the developed solution are given.

Keywords: Intelligent, Wi-Fi network, Data log file

1. Introduction

The interest of data management is important for industrial processes and has increased in parallel with the development of working machines and the technologies applied in these processes [1], [2], [3]. The analysis of these data provides a positive feedback in increasing the quality and quantity of work tasks that are subject to industrial processes. In modern industrial plants, the basic commitment is to collect, visualize and distribute data about quantities important to the process. These quantities, on one hand are process data that describe the industrial process (mass of matter, single pieces etc.), and on the other hand, they are quantities important for the maintenance of the working machines (current, temperature, pressure, flow, energy etc.). Figure 1 shows a block diagram of one intelligent system built in industrial plants.

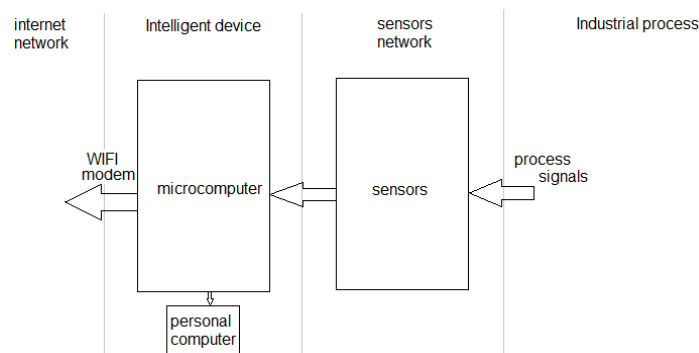

Figure 1. Block diagram of one intelligent system built in industrial plants

From Figure 1 it can be seen that the intelligent system is based on a microcomputer. It collects data about the quantities of the industrial process through the sensor network. The microcomputer sends this data through the Internet with a Wi-Fi modem [4]. With the UART port the microcomputer it is connected to a personal computer from which the data is sent to the Intra network. This hardware architecture, on the one hand, provides data adequate to the conditions in the industrial process to be collected and visualized on LCD displays and on a personal computer, and on the other hand, the possibility for the distribution of data in the Internet network is created.

2. Design on intelligent sensors Wi-Fi network

In this part an intelligent sensor network is designed. The designed solution collects data from six measuring points, as follows: measuring point 1- moisture data (H1); measuring point 2- temperature data (T1); measuring point 3- moisture data (H2); measuring point 4- temperature data (T2); measuring point 5-data for gas CO (CO); measuring point 6-temperature data (T3). In Figure 2 the block diagram of the specific solution of the intelligent sensor network is shown.

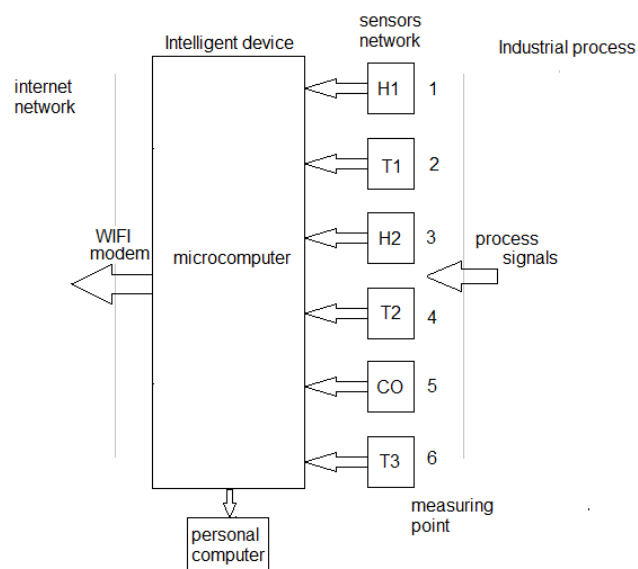

Figure 2. Block diagram of the specific solution of the intelligent sensor network

The main part of the intelligent system is the microcomputer. In the solution NodeMCU ESP8266 [5], [6] is selected. This microcomputer supports a Wi-Fi connection. For measuring point 1, 2 sensor DHT11 is selected. This sensor measures humidity (H1) and temperature (T1). For measuring points 3, 4 the sensor DHT22 is selected. This sensor measures humidity (H2) and temperature (T2). For measuring point 5 the sensor MQ-7 is selected. This sensor measures the concentration of the CO gas. For measuring point 6, the sensor DS18B20 [7] is selected. This sensor measures temperature (T3).

2.1 Features of the used hardware

Microcomputer NodeMCU ESP8266

The NodeMCU ESP8266 development board comes with the ESP-12E module containing ESP8266 chip having the Tensilica Xtensa 32-bit LX106 RISC microprocessor. This microprocessor supports RTOS and operates at 80MHz to 160 MHz adjustable clock frequency. NodeMCU has 128 KB RAM and 4MB of Flash memory to store data and programs. Its high processing power with in-built Wi-Fi / Bluetooth and Deep Sleep Operating features make it ideal for IoT projects. NodeMCU can be powered using a Micro USB jack and a VIN pin (External Supply Pin). It supports UART, SPI, and I2C interface. In Figure 3 NodeMCU ESP8266 and its pinout are shown.

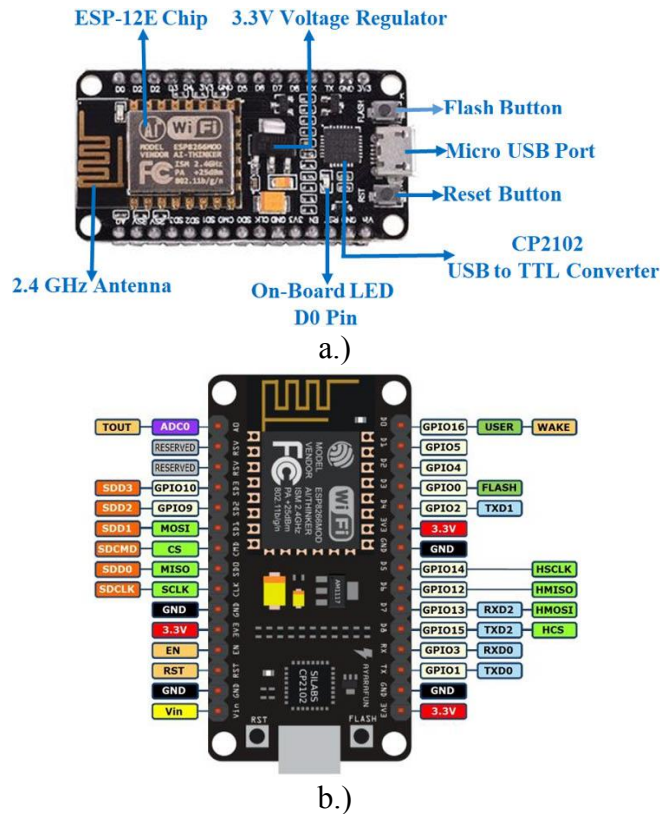

Figure 3. a.) NodeMCU ESP8266 and b.) its pinout

NodeMCU is an open-source based firmware and development board specially targeted for IoT based Applications. It includes firmware that runs on the ESP8266 Wi-Fi SoC from Espressif Systems, and hardware which is based on the ESP-12 module. NodeMCU Development Board Pinout Configuration is given in [5].

NodeMCU ESP8266 Specifications & Features

- Microcontroller: Tensilica 32-bit RISC CPU Xtensa LX106
- Operating Voltage: 3.3V
- Input Voltage: 7-12V
- Digital I/O Pins (DIO): 16
- Analog Input Pins (ADC): 1
- UARTs: 1
- SPIs: 1
- I2Cs: 1
- Flash Memory: 4 MB
- SRAM: 64 KB
- Clock Speed: 80 MHz
- USB-TTL based on CP2102 is included onboard, Enabling Plug n Play
- PCB Antenna
- Small Sized module to fit smartly inside your IoT projects

The NodeMCU ESP8266 board can be easily programmed with Arduino IDE since it is easy to use.

DHT11 humidity and temperature sensor

The DHT11 is a commonly used temperature and humidity sensor. The sensor comes with a dedicated NTC to measure temperature and an 8-bit microcontroller to output the values of temperature and humidity as serial data.

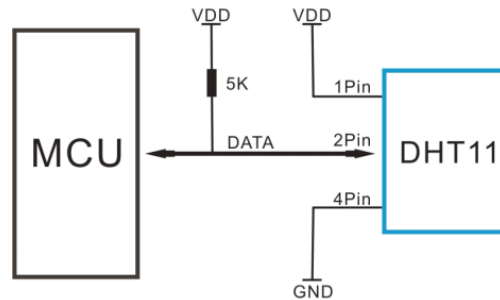

Figure 4. *Connection diagram for DHT11 sensor*

The sensor is also factory calibrated and hence easy to interface with other microcontrollers. The sensor can measure temperature from 0 °C to 50 °C and humidity from 20 % to 90 % with an accuracy of ± 1 °C and ± 1 %. The DHT11 sensor is factory calibrated and outputs serial data and hence it is highly easy to set it up. The connection diagram for this sensor is shown in Figure 4. From Figure 4 it can be seen that the data pin is connected to an I/O pin of the MCU and a 5K pull-up resistor is used. This data pin outputs the value of both temperature and humidity as serial data. For interface of DHT11 with Arduino, there are ready-made libraries for quick start. If it is needed to interface it with some other MCU, then the datasheet given below will come in handy. The output given by the data pin is sent in the order of 8-bit humidity integer data + 8 bit the Humidity decimal data + 8 bit temperature integer data + 8 bit fractional temperature data + 8 bit parity bit. To request the DHT11 module to send these data, the I/O pin must be momentarily made low and then held high as shown in the timing diagram in Figure 5.

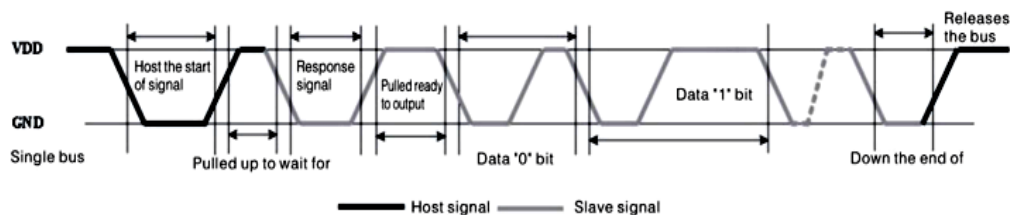

Figure 5. *Timing diagram for the DHT11 sensor*

The duration of each host signal is explained in the DHT11 datasheet, with neat steps and illustrative timing diagrams. This sensor can be used for measuring temperature and humidity, local weather station, automatic climate control, and environment monitoring. In Figure 6 the DHT11 sensor in real size with its pinout is shown.

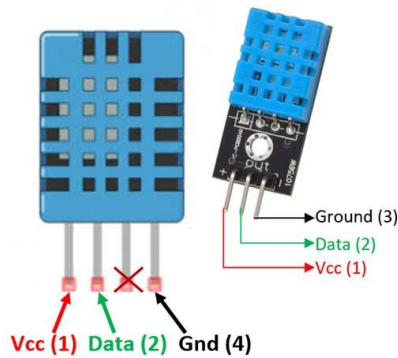

Figure 6. *DHT11 sensor in real size with its pinout.*

DHT11 Specifications:

- Operating Voltage: 3.5 V to 5.5 V
- Operating current: 0.3 mA (measuring) 60 uA (standby)
- Output: Serial data
- Temperature Range: 0 °C to 50 °C
- Humidity Range: 20 % to 90 %
- Resolution: Temperature and Humidity both are 16-bit
- Accuracy: ± 1 °C and ± 1 %

The DHT11 sensor can either be purchased as a sensor or as a module. Either way, the performance of the sensor is same. The sensor comes as a 4-pin package out of which only three pins are used, whereas the module comes with three pins as shown above. The only difference between the sensor and the module is that the module will have a filtering capacitor and a pull-up resistor inbuilt, and for the sensor they are externally used if required.

DHT22 humidity and temperature sensor

In Figure 7 the DHT22 sensor is shown. The DHT22 is a commonly used temperature and humidity sensor. This sensor has same features as DHT11 but different range of temperature from -40 °C to 80 °C and humidity from 0 % to 100 % with an accuracy of ± 1 °C and ± 1 %.

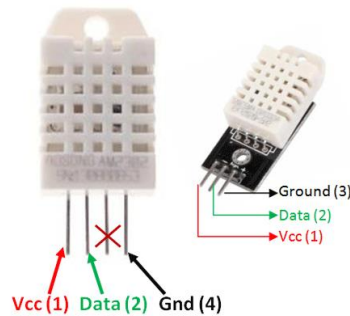

Figure 7. *DHT22 sensor in real size with its pinout*

MQ-7 CO gas sensor

In Figure 8 the MQ-7 gas sensor is shown. The MQ-7 gas sensor applies SnO₂, which has a lower conductivity in the clear air as a gas-sensing material. In an atmosphere where there may be carbon monoxide in a certain density, the conductivity of the gas sensor raises as the concentration of carbon monoxide increases.



Figure 8. MQ-7 gas sensor

This module can be applied to households and industrial gas leakage alarms, portable gas detecting devices etc. The detecting range is 0 ppm-2000 ppm (ppm is concentration in million pieces) carbon monoxide. In Table 1 pins connection on the MQ-7 sensor are given.

Table 1: Pin connection on the MQ-7 sensor.

Pin No.	Symbol	Description
1	DOUT	Digital out
2	AOUT	Analog out
3	GND	Ground
4	Vcc	+Power supply (2.5-5)V

In Figure 9 the sensitivity characteristics on the MQ-7 gas sensor is shown.

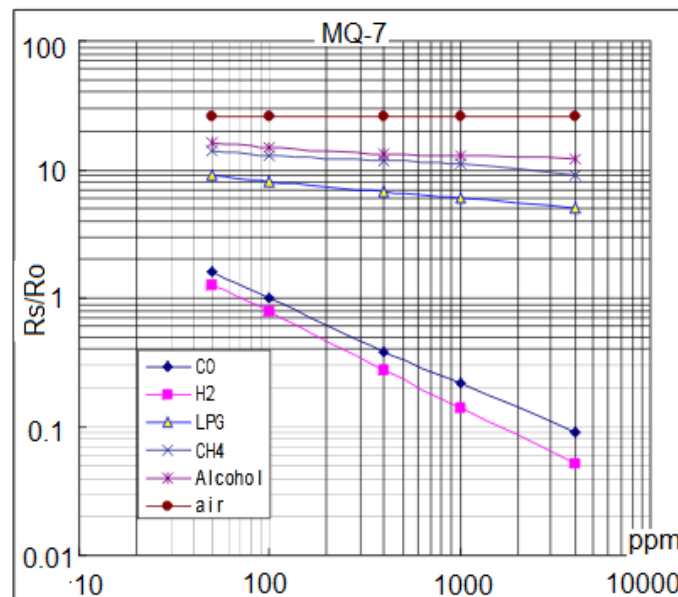

Figure 9. Sensitivity characteristics on the MQ-7 gas sensor

From Figure 9 it can be seen that the MQ-7 sensor is sensitive to several gases. The curves on Figure 9 are obtained for the temperature of 20°C, humidity 65 % O2 concentration 21 %, RL=10kΩ. Ro is the sensor resistance at 100 ppm CO in the clean air. Rs is the sensor resistance at various concentrations of gases.

OPERATION PRINCIPLE. The surface resistance of the sensor Rs is obtained through effected voltage signal output of the load resistance RL which series-wound as:

$$R_s \backslash R_L = (V_c - V_{RL}) / V_{RL} \quad (1)$$

In Figure 10 alterable situation of RL output signal is shown when the sensor is shifted from clean air to carbon monoxide (CO). The output signal is measured within one or two complete heating periods (2.5 minute from high voltage to low voltage).

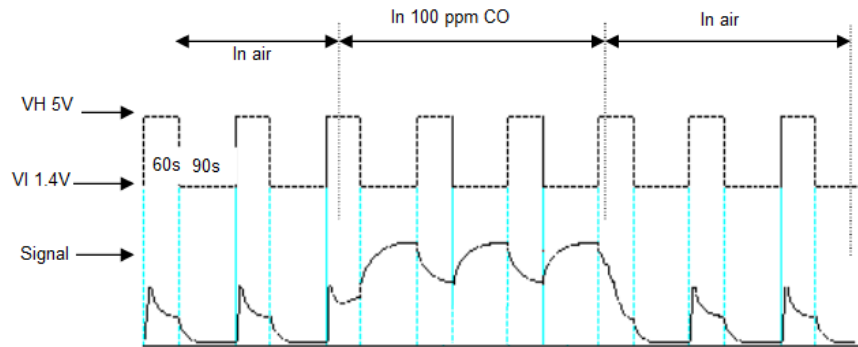

Figure 10. Signal on analog output at the MQ-7 sensor

A sensitive layer of the MQ-7 gas sensitive components is made of SnO₂ with stability. So, it has excellent long-term stability. Its service life can reach 5 years under using condition.

SENSITIVITY ADJUSTMENT Resistance value of MQ-7 is different for various kinds and various concentration gases. So, when using these components, sensitivity adjustment is necessary. It is recommended to calibrate the detector for 200 ppm CO in air and use value of load resistance (RL) about 10 K Ω (5K Ω to 47 K Ω). For accurate measurement, the proper alarm point for the gas detector should be determined after considering the temperature and humidity influence. The sensitivity adjusting program: a. Connect the sensor to the application circuit. b. Turn on the power, keep preheating through electricity over 48 hours. c. Adjust the load resistance RL until you get a signal value which is the response to a certain carbon monoxide concentration at the end point of 90 seconds. d. Adjust another load resistance RL until you get a signal value which is a response to a CO concentration at the end point of 60 seconds.

DS18B20 temperature sensor

The DS18B20 digital thermometer provides 9-bit to 12-bit Celsius temperature measurements and has an alarm function with nonvolatile user-programmable upper and lower trigger points. The DS18B20 communicates over a 1-Wire bus that, by definition, requires only one data line (and ground) for communication with a central microprocessor. In Figure 11 the DS18B20 sensor is shown.



Figure 11. DS18B20 sensor

In addition, the DS18B20 can derive power directly from the data line (“parasite power”), eliminating the need for an external power supply. Each DS18B20 has a unique 64-bit serial code, which allows multiple DS18B20s to function on the same 1-Wire bus. Thus, it is simple to use one microprocessor to control many DS18B20s distributed over a large area. Applications that can benefit from this feature include HVAC environmental controls,

temperature monitoring systems inside buildings, equipment, or machinery, process monitoring and control systems. It measures temperatures from $-55\text{ }^{\circ}\text{C}$ to $+125\text{ }^{\circ}\text{C}$ ($-67\text{ }^{\circ}\text{F}$ to $+257\text{ }^{\circ}\text{F}$) by $\pm 0.5\text{ }^{\circ}\text{C}$. The accuracy is from $-10\text{ }^{\circ}\text{C}$ to $+85\text{ }^{\circ}\text{C}$. The power supply range is 3.0 V to 5.5 V . The programmable Resolution is from 9 Bits to 12 Bits. In Figure 12 the block diagram on the DS18B20 sensor is shown.

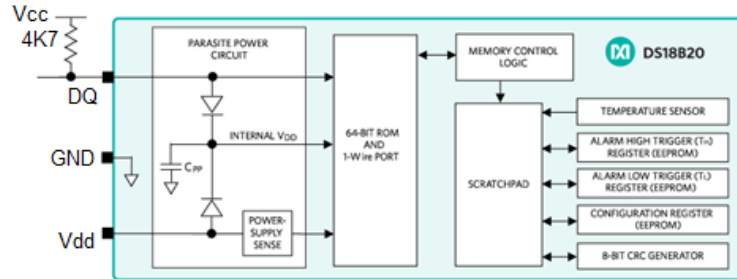

Figure 12. Block diagram on the DS18B20 sensor

In Figure 13 the connection circuit on NodeMCU ESP8266 with DS18B20 temperature sensor is shown.

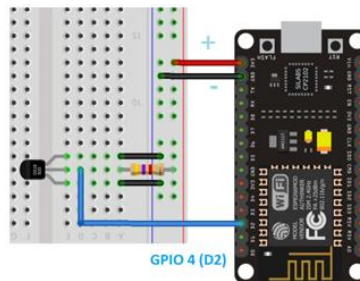

Figure 13. Connection circuit on NodeMCU ESP8266 with the DS18B20 temperature sensor

3. Experimental results

The design of an intelligent Wi-Fi sensor network consists of a hardware design and a software design.

Hardware design

According to the description of the characteristics of the hardware components given above and the main purpose of the paper, Figure 14 shows the electrical circuit of the intelligent Wi-Fi sensor network.

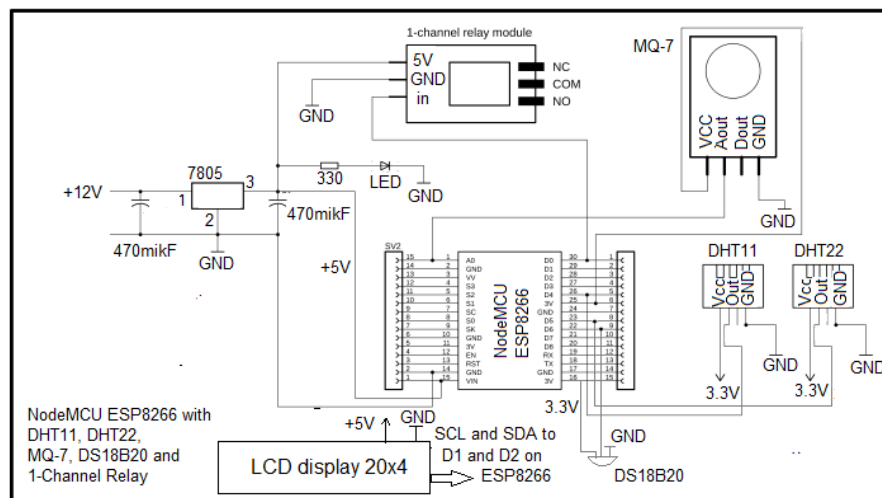

Figure 14. Electrical circuit of the intelligent Wi-Fi sensor network

The circuit is supplied by 5 V, which is obtained from the voltage regulator 7805. The sensors are supplied with 3.3 V obtained from NodeMCU ESP8266. The output from the sensors is connected to a digital pin on the ESP8266, DHT11 to D4 pin, DHT22 to D5, MQ-7 to D0, DS18B20 to D6. On the pins D1 and D2 are connected SCL and SDA signals for communication from ESP8266 to LCD display.

Software design

The software is written in micro C. The NodeMCU ESP8266 software is compatible with the Arduino IDE platform. The software ensures that the microcomputer receives the signals from the sensors and, after processing, displays the current values on the LCD display, sends them as a data log file for building a database compatible with an excel file, and distributes them to the Wi-Fi Internet network.

In Figure 15a shows the experimental prototype on the intelligent Wi-Fi sensor network, and in Figure 15b the excel data log file is shown. For remote transmission and display of current values of measurement data in the WI-FI network SCADA is built based on an APP Store platform. In Figure 16 the screen of an Android mobile device on which are shown the current values of the measurement data is shown. In addition to the measurement data on the screen of the Android device, there is a button that turns on the relay connected to ESP8266 (shown in the Figure 14).

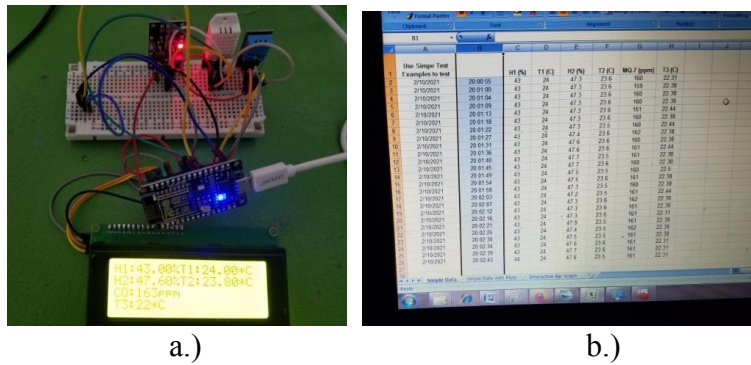

Figure 15. Experimental results: a.) prototype on the intelligent WI-FI sensor network and b.) excel data log file

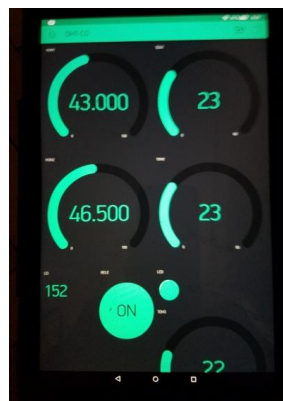

Figure 16. Screen of an Android mobile device on which the current values of the measurement data are shown

4. Conclusion

In this paper, along with theoretical analysis, an intelligent Wi-Fi sensor network is designed and practically realized. The sensor network enables data from six metering points taken from an industrial process to be measured, processed, visualized on an LCD screen, sent as a data log in an excel file, and distributed remotely via a Wi-F connection. The solution also provides the ability to remotely control the process quantities.

References

- [1] S. Bennett, S. Linkens, Computer Control of Industrial Processes, D.A. (Eds.), IEEE, 1982.
- [2] Ching-Lai Hor and Peter A. Crossley, Knowledge Extraction from Intelligent Electronic Devices, Lecture Notes in Computer Science pp. 82-111, January 2005.
- [3] Teen-Hang Meen, Wenbing Zhao and Cheng-Fu Yang Special Issue on Intelligent Electronic Devices Reprinted from: Electronics 2020, 9, 645.
- [4] By M.A. Matin and M.M. Islam, Wireless Sensor Network, <https://www.intechopen.com/books/wireless-sensor-networks-technology-and-protocols/overview-of-wireless-sensor-network> September 6th 2012, DOI: 10.5772/49376
- [5] Manoj R. Thakur , NodeMCU ESP8266 Communication Methods and Protocols: Programming with Arduino IDE, 2018
- [6] ESP8266: Programming NodeMCU Using Arduino IDE - GetStarted With ESP8266, <https://stoveraci.firebaseio.com/aa009/esp8266-programming-nodemcu-using-arduino-ide-get-started-with-esp8266-by-upskill-learning-1534822666.pdf>
- [7] DS1820, DATASHEET, Dallas Semiconductor.
- [8] <https://www.theengineeringprojects.com/2018/06/introduction-to-arduino-nano.html>.

Goce Stefanov
University of Goce Delcev Stip
Electrical Engineering Faculty
R. N. Macedonia
goce.stefanov@ugd.edu.mk

Maja Kukuseva Paneva
University of Goce Delcev Stip
Electrical Engineering Faculty
maja.kukuseva@ugd.edu.mk

Elena Stefanova Zafirova
OneSky Flight, Dallas, Texas
USA
Elena.zafirova@onesky.com