

UPGRADE AND APPLICATION OF AUTOMATION SYSTEM IN T.S. 110/35/10 KV “PETROVEC”

Vasilija Sarac¹, Dragan Minovski², Goran Cogelja³

Faculty of Electrical Engineering, University “Goce Delcev”, P.O. Box 201, 2000 Stip, R. Macedonia email
e-mail: vasilija.sarac@ugd.edu.mk¹, dragan.minovski@ugd.edu.mk², goran.cogelja@ugd.edu.mk³

Miroslava. Smitkova⁴

Affiliation

e-mail: Slovak university of Technology in Bratislava, Ilkovicova 3, 812 Bratislava Slovakia,
miroslava.smitkova@stuba.sk⁴

Abstract:

35/10 kV substation Petrovec operated for many years as part of the power distribution network of Skopje, the capital of the Republic of Macedonia. Due to the increase of the consumption, the substation was upgraded on 110 kV voltage level. The upgrade of the substation included 110kV switchyard and replacement of the existing 35/10 kV switchyard with new enlarged indoor 35/10 kV switchgears. The project included installation of new automation system Sicam PAS for remote control of switchgear devices on 110 kV level as well as connection and data exchanging with local control system of 10 kV level. Another level of automation included installation of hardware and software solution for remote control and read out of protection relays. Complete hardware and software solution is product of company Siemens.

Keywords

Substation automation, remote control of protection relays, substation upgrade

1 INTRODUCTION

The substation “Petrovec” 35/10 kV has operated for many years as a part of the power distribution network of Skopje, the capital of republic of Macedonia. Increase of consumption of electricity in the region of city Skopje, has lead to upgrade of s.s. 35/10 kV Petrovec to 110 kV level. Reconstruction included installation of new 110 kV switchyard, as well as replacement of complete 35/10 kV switchyard with new and enlarged 35/10 kV switchgears. Besides replacement and upgrade of primary equipment also complete reconstruction and modernization was done in the part of secondary equipment: installation of new protection relays and installation of new system for substation remote control Sicam PAS. For that purpose on 110 kV side were installed intelligent electronic devices-IEDs – bay control units (BCUs) capable of handling the complex control and monitoring tasks, besides the protection relays for 110 kV side. On 10 and 35 kV side combined protection and control unites were installed which enable connection and data exchanging within 10, 35 and 110 kV level and with higher control center while carrying out simultaneously the protection functions in 10 and 35 kV switchgears. On that way, s.s Petrovec was integrated in system for local control and monitoring on substation level but in the same time using IEC 101 protocol it was integrated in the control system on the level of whole distribution network in the city of Skopje-Distribution Dispatching Centre Skopje (DDC Skopje).

Another level of automation control was implemented with of system for relays remote control-DIGSI Remote.

2 PROJECT DEFINITATION AND REQUIREMENTS

Reconstruction of s.s Petrovec was consisted of two major parts: installation of protection (FTU) and control units (BCU) on 110 kV level and installation of combined protection and control units on 35 and 10 kV level. Installed system for control is integrated to DDC Skopje via protocol IEC 101. Another level of automation is represented with DigsI Remote system which integrates all the protection relays in the substation and enables remote parameterization and read out of protection data for 110 kV level and parameterization and read out of protection data as well as circuit breaker control for 10 and 35 kV level. RS485 communication interface is used for interconnection of all relays and their integration in DIGSI Remote while protocol PRFIBUS FMS is used on RS 485 interface for integration of all protection relays and bay control units into control system-SICAM Pas CC. Control of switching devices on 110 kV level is done from BCU and SICAM Pas CC system while on 110 kV level protection relays are used only for protection purposes. On 10 and 35 kV level protection relays are fulfilling the protection but as well control functions regarding control of switching devices. In Fig 1 and 2 is presented principal requirement regarding 110 kV and 35/10 kV protection and control system respectively.

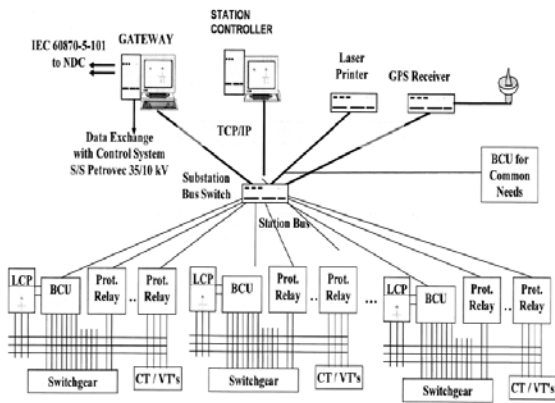

Fig. 1. 110 kV system definition and requirement

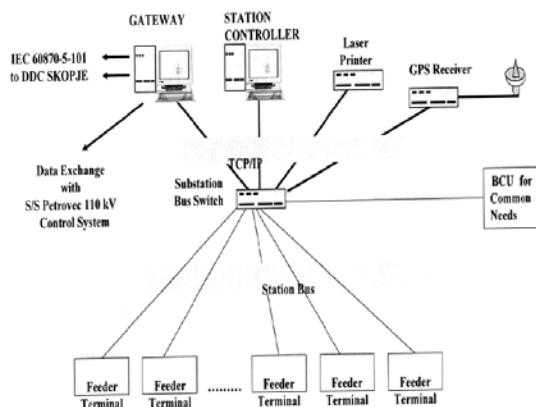

Fig. 2. 35 kV system definition and requirement

3. SYSTEM CONFIGURATION AND CHARACTERISTICS

According to project requirement system for remote control SICAM PAS, product of company Siemens, was implemented in the project part regarding control system while DIGSI remote was implemented in project part regarding remote control of protection. The SICAM PAS system is an open modular structured telecontrol and substation automation system for digital energy automation. The specific functions of a telecontrol system are combined with those of a programmable controller automation system. In Figs. 2 and 3 is presented technical solution of automation system regarding SICAM PAS system and DIGSI remote on 110 kV and 35 kV level respectively. According to the substation configuration on 110 kV level there are two transformers, one coupler switchgear, and two over-head transmission lines. Applied solution of automation system on 110 kV level is based on principle that protection and control functions are completely separated in each 110 kV cubicle. Intelligent Electronic Devices (IEDs) for protection functions are installed in protection relays (e.g. 7SA633 for distance protection of transmission lines) while for control purposes are used BCUs-6MD63 which are fully capable of performing all control and monitoring functions. Their connection to the SICAM PAS station unit is established using PROFIBUS FMS protocol while

connection to DDC Skopje is established via IEC 101. The 110 kV protection and control cubicles are presented in Fig. 5.

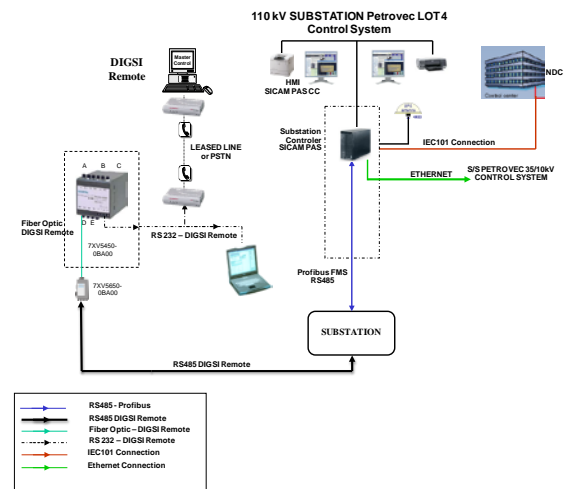

Fig. 3. 110 kV level system configuration

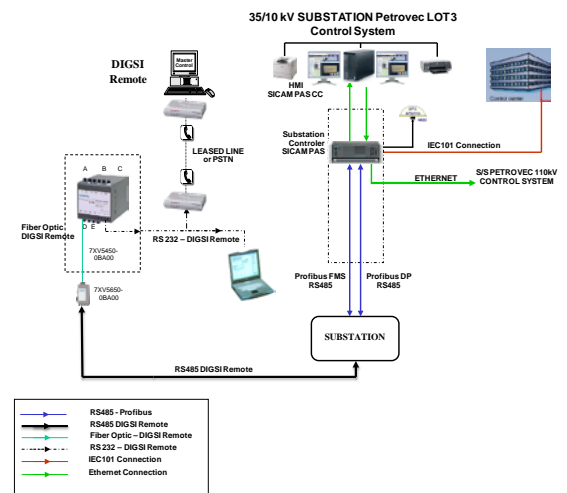

Fig. 4. 35/10 kV level system configuration

All substation common signals are led in one programmable logic control module ET 200 S containing 64 digital inputs and 10 analog inputs. As for automatic control of transformer tap-changer which enables automatic regulation of transformer secondary voltage Eberle REGSys™ is used. It is also integrated in substation control system with the aid of IEC 101 protocol. Each REG-D controller can be used as a controller and at the same time as a measuring transformer, recorder and statistics unit. In measuring transformer mode all important network measured values are displayed, in recorder mode the time progression of the voltage being controlled and a second selectable measured value are registered. It has PC-supported archiving and evaluation of recorder data [1].

On 10 and 35 kV level are used numerical combined protection and control units 7UT63 which have large display and full set of protection, control and monitoring functions for specified 10 and 35 kV switchgear. Part of 35 kV and 10 switchgear is presented in Fig. 6 and 7.

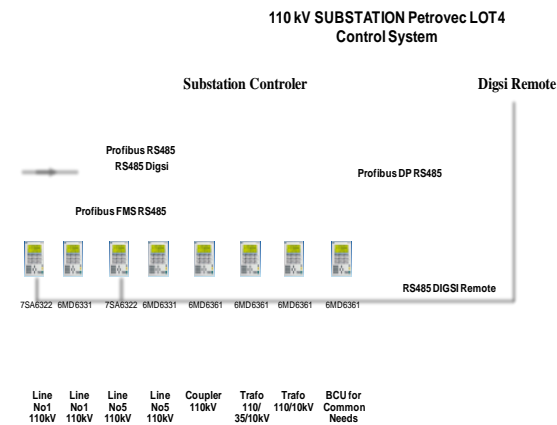

Fig. 5 110 kV protection and control cubicles

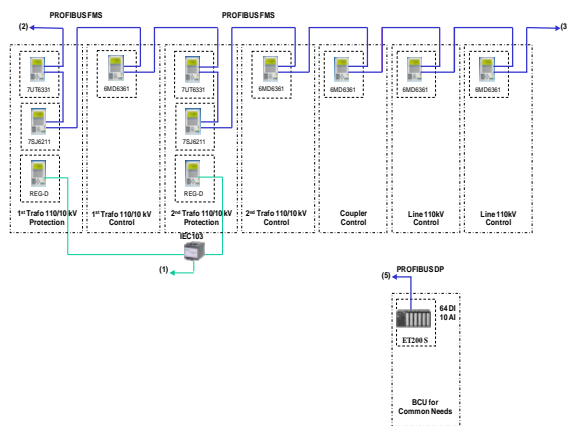

Fig. 6 35 kV protection and control cubicles



Fig. 7 10 kV protection and control cubicles

4. SISTEM'S CHARACTERISTICS

4.1 SICAM PAS system's characteristics

With its features and its modular expandability, SICAM PAS covers a broad range of applications and supports distributed system configurations. A distributed SICAM PAS system operates simultaneously on several computers. SICAM PAS can use existing hardware components and communication standards as well as their connections. It controls and registers the process data for all devices of a substation, within the scope of the data transfer protocols supported. SICAM

PAS is a communication gateway. This is why only one single data connection to a higher-level system control center is required. SICAM PAS enables integration of a fully graphical process visualization system directly in the substation. Time synchronization of all process data is archived with a module in a station unit for the time synchronization of the connected IED (if supported by the protocol) and the connected HMI-PCs (SICAM PAScc). The clock time receiver (GPS) is connected to a PC slot of the SICAM PAS station unit (Fig.8).



Fig. 8. SICAM PAS station unit

The SICAM PAS is the clock time master in the system and synchronizes connected bay units and I/O function modules. The time stamp of acquired information is allocated as follows: time stamping of the centrally acquired information items is done directly on the I/O function modules. Bay units which are connected via PROFIBUS FMS are each clock-synchronized through the communication connection. The information items are assigned a time stamp there (time with date) for the above protocols, in the bay units directly. Bay units which are connected via IEC 60870-5-103, are clock synchronized through the communication connection. The information items are allocated there a time stamp (time without date) for the above logs directly in the bay units. The SICAM PAS adds the date. Further control aspects of SICAM PAS are: interlocking functions such as bay blocking and telecontrol blocking, redundancy, and software for evaluation of measured and metered values as well as software for automatic retrieval of fault recordings from protection relays [2].

SICAM PAS features bay blocking and telecontrol blocking functions. The telecontrol blocking function can also be configured for specific channels so as to prevent the transfer of information to one particular control centre during operation, while transfer continues with other control centers. The bay blocking and telecontrol blocking functions act in both directions: the signalling and the command directions. Channel-specific switching authority also makes it possible to distinguish between local control (SICAM PAS CC) and remote control for the switching direction, but also between control center connections. Circuit-breakers can be controlled in synchronized/unsynchronized mode.

The SICAM PAS station unit can be used in a duplicate configuration and can be upgraded to further boost the availability of the station control level. This duplication is possible with IEDs or substation devices that support simultaneous

communication with two masters or clients (IEC 61850) SICAM PAS CC serves as the process visualization system.

IndustrialX-Controls are used to control and monitor switchgear. These switching device objects support four different forms of presentation (IEC, DIN, SINAUT LSA, SICAM) for circuit-breakers and disconnectors. It is also possible to create bitmaps (defined for a specific project) to represent switching devices, and to link them to the objects. For informative visualization, not only nominal and spontaneous flashing are supported, but also the display of various device and communication states.

Software package SICAM Valpro can be used to evaluate measured and metered values. It not only allows a graphical and a tabular display of archived values, but also enables subsequent evaluation functions such as minima, maxima and averages (on an hourly or daily basis).

Software package SICAM RecPro supports automatic retrieval and archiving of fault recordings from protection units connected with IEC 60870-5-103, PROFIBUS FMS and IEC 61850. SICAM PAS has following features:

- Multilingual capability
- All operation and monitoring functions on-board. This include not only the graphic system for plant displays and the signalling and archiving system for alarms and measured values, but also a reporting and logging system. Further advantages are integrated user administration, along with the granting and checking of access rights for configuration and runtime operations.
- Consistently scalable, even via the Web in conformity with requirements, the bandwidth ranges from simple single-user through to distributed multi-user systems with redundant servers and multi-site solutions with Web clients.
- Open standards for easy integration

Using any external tools, archived data can be accessed through a series of open interfaces (such as SQL and ODBC) for further editing. Manufacturer-independent communication with lower level controllers (or with applications such as MS Excel) is supported with OPC (OLE for Process Control). Visual Basic for Applications (VBA), VBScript or ANSI-C creates an ideal scope for project-specific solutions.

4.2 DIGSI Remote system's characteristics

Remote operation and read out of protection relays by DIGSI-Remote is realized with converter optical fibre cable to RS485- 7XV5650. The RS485 – FO converter is used to convert RS485 signals to FO transmission signals in full duplex mode. It has one FO channel for transmission and one for receiving, as well as a protected RS485 interface rated to

withstand 2 kV discharges, thus allowing direct connection to the serial system interface of SIPROTEC relays. It is designed to be used in substations or isolated, interference-free transmission of serial signals to a central unit, a star coupler or a PC (Fig. 9).



Fig. 9. Converter Optical Fibre Cable to RS485
7XV5650

The mini star-coupler multiplies an optical signal received at an input for up to four outputs (Fig.10). A signal received at one of the outputs is transmitted via the input interface to a central unit or to an upstream mini star-coupler or converter. As the mini star-coupler does not transmit selectively to individual outputs, the protocols used for data transmission must operate with unique DTE addresses, so all units “hear” the central interrogation, but only the addressed unit answers to the request (e.g. IEC 60870-5-103 or DIGSI). Data are transmitted in transparent full duplex mode. An RS232 interface is provided for direct serial communication at each mini star-coupler. As long as this interface is in use, the optical input interface to the central unit is blocked. Mini star coupler houses one optical input and up to five optical outputs. Spanned distance is 1.5 km with 62.5/125 μm multi-mode fibre.



Fig.10. Mini Star Coupler 7XV5450

Bay control unites and protection relays are SIPROTEC 4 family product of Siemens. The SIPROTEC 4 devices are digitally operating protection devices which also meet control and monitoring tasks [3,4]. This supports the user in economical operation management and ensures reliable supply of consumers with electrical energy.

Integration of the SIPROTEC 4 protection and bay device generation is possible in a particularly simple manner, since uniform concepts were implemented during development. Depending on the specified task, devices are used with separate protection and control instrumentation functions or a solution is selected which combines both requirements on the bay level. Depending on function the devices are provided with an operating panel incorporating a graphic or a four-tier alphanumeric display. In this particular project 6MD633 bay control units are used in 110kV Bays.



Fig. 11 . BCU -6MD633 for control functions

In presented BCUs number of switching devices is limited to available number of inputs and outputs. Position of the switching element is shown on the graphic display. Local/remote switching is possible via key switch. They enable switchgear interlocking isolator/c.b. They have available event log: switching statistics, monitoring functions, operational measured values and energy metering values.

4. HUMAN-MACHINE INTERFACE

In the SICAM PAS substation automation system the fully graphic process visualization system SICAM PAScc is the interface between the operator and the computer supported monitoring and control system, the Human Machine Interface-HMI. For efficient operation management a multiplicity of individual information items must be administered and displayed quickly and transparently. The plant status is correctly presented and logged at any instant. Essential indications, and measured and counter values of previous time intervals are archived such that they are available at any time for specific evaluations in curve or tabular form. As for the software requirements WINDOWS XP operating system is needed. After starting of runtime mode by SICAM PAScc, the overview diagram of the plant is displayed (Fig.12). The diagram display is approx. 5 seconds and the update time approx. 2 seconds for the switch objects and the measured value variables. If communication to

a device or a module is faulty, the switching device or information items acquired are displayed with the last registered state, in cyan (light blue). If communication between SICAM PAS and SICAM PAScc is faulty, all switching device are displayed dark green indicating fault status, the background of the measured values is coloured in dark grey.

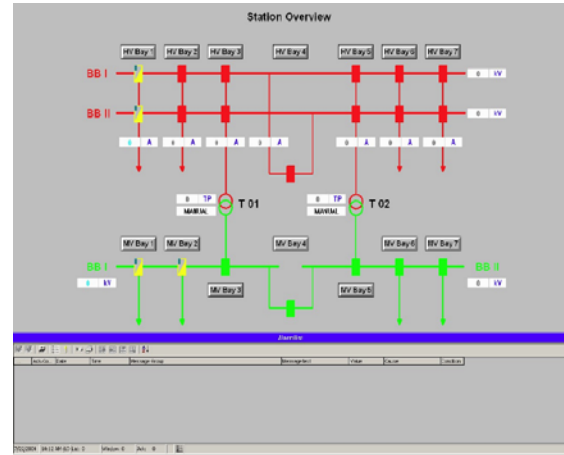

Fig.12. General substation overview in SCADA system

Status of the switching devices is graphically changed according to the actual state of the switching device- Table 1.

Table 1: Switching device dynamic symbol

Switching device	Status	Symbol on single line diagram
Circuit breaker and disconnecter	On	
Circuit breaker and/or disconnecter	Off	
Circuit breaker and disconnecter	Disrupted	

Buttons with bay names are displayed above the busbars. By clicking these buttons the detail picture can be activated.

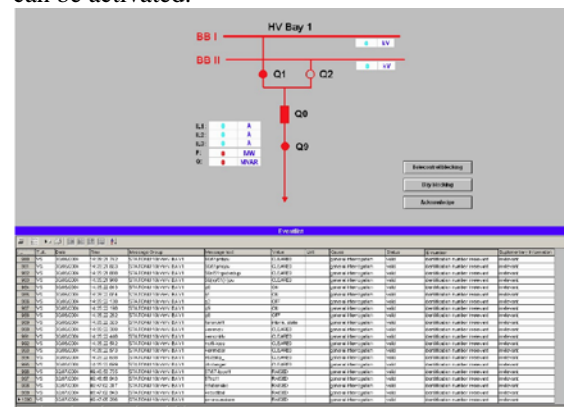

Fig. 13. Detailed overview of 110 kV feeder

The event list is selected by pressing the event list button and the alarm list is selected by pressing the alarm list button. All indications are listed in the event list. Coming entries in the alarm list, which need to be acknowledged are displayed in red. Going entries in the alarm list, which need to be

acknowledged are displayed in green. All other entries are shown in black.

Zeit	Objekt	Wert	Objekt	Wert	Objekt	Wert	Objekt	Wert	Objekt	Wert
11.07.2014 11:24:00	11.07.2014 11:24:00	11.07.2014 11:24:00	11.07.2014 11:24:00	11.07.2014 11:24:00	11.07.2014 11:24:00	11.07.2014 11:24:00	11.07.2014 11:24:00	11.07.2014 11:24:00	11.07.2014 11:24:00	11.07.2014 11:24:00

Fig. 14. SCADA event list

The SICAM PAScc Valpro package application (measured/counter value processing unit) is used for processing, display and printout of archived measured and counter values. Archiving of measured and counter values is done every 15 minutes. SICAM PAScc Valpro is started using a button in the upper area of the WinCC screen. After start the main window is displayed. The measured and counter values (variables) to be displayed in a variable group are selected there. The presentation can be in curve or tabular.

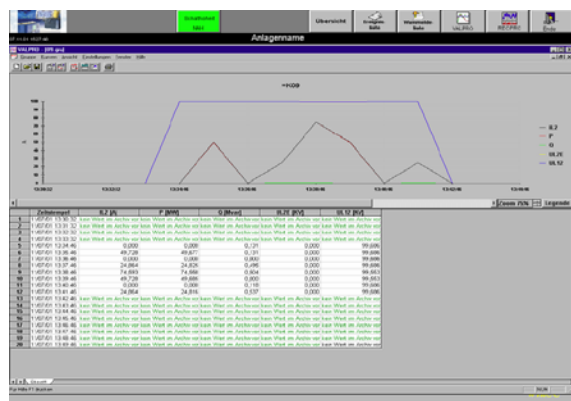

Fig. 15. SICAM PAScc Valpro window of metered values

6. CONCLUSION

Modern contemporary solution of SCADA systems-Sicam PAS, product of company Siemens is implemented in reconstruction and upgrade of

high voltage substation 110/35/10 kV T.S. "Petrovec" in the city of Skopje. The complete high voltage switchyard 110 kV is remotely controlled and monitored from Sicam PAS system by the aid of Sicam PAScc visualization program interconnected via Sicam station unit with distributed bay control units each one placed in each 110 kV bay. On 110 kV level control and protection functions are completely separated by using separate hardware units for protection and control i.e. bay control units for control and monitoring functions and numerical protection relays for protection functions. On 35 and 10 kV level control and protection functions are combined in one complex numerical protection relay enabling control of 35 and 10 kV switchyard to be performed locally from protection relays placed in 35 and 10 kV panels as well as remotely from SCADA system. Substation control system via protocol IEC 101 is connected to Dispatching Distribution Center of city Skopje. Bay control units and protection relays on 110 kV level as well as protection relays in 35 and 10 kV bays are connected to station control unit via PROFIBUS FMS. All important process parameters are remotely controlled including transformer tap-changer position. This contemporary software solution has considerably improved the operation of complete substation enabling to be remotely controlled and monitored thus cutting down the operational cost and reducing the time for faults location and cost for everyday maintenance.

3 REFERENCES

- [1] Vasilija Sarac, Dragan Minovski "Application of Sicam Pas system in automation and control of T.S. 400/110 kV Stip", "10th International Conference Control of Power System", Tatranske Matliare, Slovak Republic, May 2012, p.p 161-162.
- [2] Siemens, *Power Engineering Guide*, Erlangen: Publics Pro, 2008.
- [3] Siemens, *SIPROEC, Numerical Protection Relays*, Catalog SIP, 2008.
- [4] Siemens, *Case studies for SIPROTEC Protection Relays and Power Quality*, 2005.