



NEW PARAMETERS FOR OPTIMIZATION OF WORKING DIESEL ENGINES AT DRILLING MACHINES

M-r Goce Stefanov, grad, electr. eng, University Goce Delcev, Stip, Electrotechnical faculty, R. Macedonia, e- mail: goce.stefanov@ugd.edu.mk, tel.:+389 32 550 567,

D-r. Risto Dambov, Ass. prof. University Goce Delcev, Stip, Faculty of Mining, R. Macedonia, e-mail: dambov2004@yahoo.com, risto.dambov@ugd.edu.mk , tel.: +389 32 550 563

ABSTRACT

In the paper is delivered solution in the electronic circuit for optimizing the work of diesel engines at drilling machines for prepare drill holes for primary blasting. in the open pit mines. Task of the electronic circuit is to ensure operation of diesel engines depending of the load according to the principles of operation diesel engine. With the decision of the circuit for optimization obtain engines to work with power against current load, and the role of the operator minimizes. The methodology for development of the solution is based of computer simulations and measurements.

Electronic circuit which is given in the paper is part of an electronic system for management with functions of this types of drilling machines. With designed solution is achieved optimal balance between basic mechanical structure of the machines and its overall management.

Keywords: *electronic circuit, optimum operation, diesel engines, hydraulic drilling machines*

1 .INTRODUCTION

Drilling machines figure 1, is heavy stationary work machine with diesel engines in parallel mode designed for excavation and loading of ore at mines [8].



Figure 1 Type of drilling machines

It is big working machine in which are implemented the latest achievements of several branches of engineering (electrical, electronics, hydraulics, mechanics) [1], [2], [6] . Two diesel engines are used with power 380kW. These are engines with six cylinders and pneumatic regulators of the pumps for injection on fuel, figure 2.

Both diesel engines work in parallel. The solution in the paper is developed because the problems and needs that occur at working of machines in one of the mines in Macedonia. Developed solution is part of electronic system that manages with basic functions, such as:

- inclusion and exclusion of diesel engines
- management with operating and stops the engines
- protection of engine from small pressure on oil, high temperature



- optimization of the system of loading
- lubrication of the shaft in the machines.

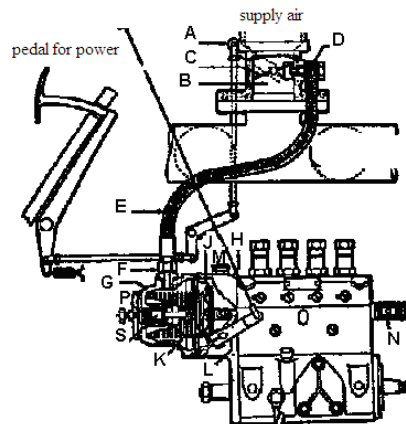

Figure 2. Pump for injection on fuel with pneumatic regulator

In this paper we retain only to the description of part of the electronic system which refers to the optimization of the mode of loading on the drilling machines.

For properly working of diesel engine of hydraulic drilling machines it is necessary to provide several conditions for its optimal functioning, including:

- The parts that are exposed on friction (main axis, gears, cylinders) should be cooled with oil lubrication with pressure from 3 to 6 bar.
- The working power of the engine will continue, if the parts which receive heat (head, block) of the parts exposed to friction are cooled by forced air or water.

The above two conditions provide diesel engines to operate with allowed temperature domain, figure 3 [6].

On the figure 3, in item 1 includes the engine. Along the line 1-2 engine works without a load (low speed). In t_1 (2) the engine achieves a working temperature of 68 ° C. This is a condition the engine to be capable to operate under a load (work with maximum speed). In t_2 (3) the engine achieves a working temperature of 82 ° C. When the engine operates under a load, the temperature of the fluid for cooling moves along the curve 3-4. When the engine stops the work under a load it is necessary to work with a small number of revolutions (idler) before it turns off. It is a point t_4 (5), when the temperature of the fluid for cooling is 68 ° C.

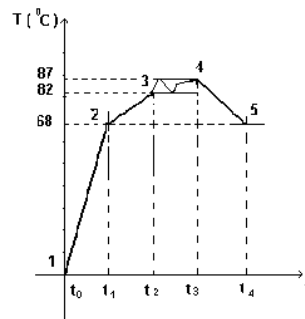

Figure 3 Temperature diagram of diesel engine

2. CIRCUIT FOR OPTIMAL OPERATION OF DIESEL ENGINE

The electronic circuit for optimization on the work of the diesel engines which is the subject of the paper follows the operation of diesel engines under load (along the curve 3-4) and based on signal for the



hydraulic pressure decide whether to allow engines to work with maximum speed or to reduce the number of revolutions of the minimum (idler) [8] [9]. Using of the electronic circuit for optimization on the work of diesel engines according to the diagram of picture 3, saving fuel and minimize the role of operator in terms of its savings.

The work on the circuit for optimal operation will be explained with help diagram of the states. For the analyze we need the following signals and conditions:

o *incoming signals*:

- loading of the drilling machines, signal the hydraulic pressure, E22
- inclusion or exclusion on the circuit for optimal operation, E112
- alternative inclusion and exclusion of the circuit for optimal operation, E113

o *Output signals*:

- reduction of supply of air on the pump for fuel, A52
- inclusion or exclusion on circuit for optimal operation, V4 (pin 4 of IC_{28})

States in which can be found a circuit for optimal work are:

- o *Excluded* circuit for optimal operation, G1
- o *Included* circuit for optimal operation, G2
- o *Alternatively turn on* of the circuit for optimal operation, G3
- o *Alternatively turn off* of the circuit for optimal operation, G4

In the figure 4 is given diagram of crossings and table of crossings of circuit for optimal work.

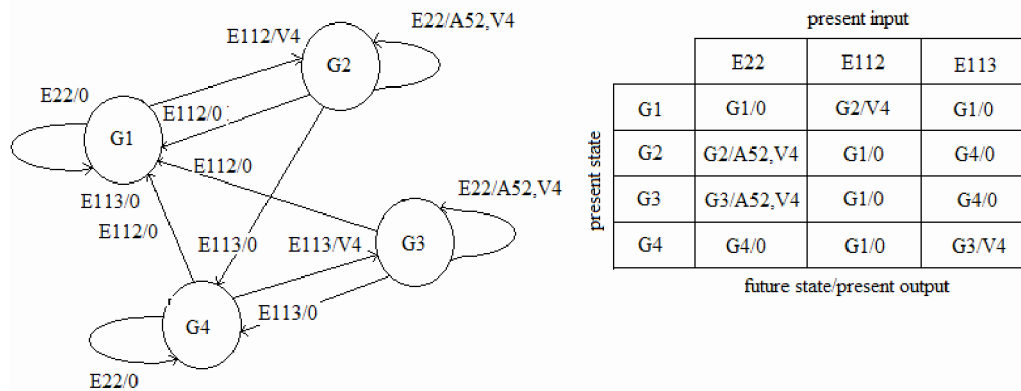

Figure 4. Diagram of crossings and table of crossings of circuit for optimal work

From the table of crossings and diagrams of crossings easily are defined the following states and the following output sequences of circuit for given initial state and input sequence. For example, if the initial state is G1 and the input sequence is E112, E22, E113, E113, the following states are G2, G2, G4, G3 and the output sequence is V4, A52-V4, 0, V4.

2.1 Description of the circuit for optimal work

The circuit for optimal operation of diesel engines, used at hydraulic drilling machines RH120C is given on the figure 5 [4], [6], [8]. In the figure 10 is given a time diagram of voltages in separate items of the circuit for optimal operation.

Consider the situation when the two diesel engines are in work under a load (handle for gas in maximum position). Input element, on the basis of which circuit for optimal operation manages with work in the diesel engines under load is switch on the servo pressure, B51. In the work of the circuit for optimal operation of diesel engines participates 4 integrated circuits, 4 transistors, one relay and several resistors, diodes and capacitors.



Circuit for reduction in the number of revolutions of the diesel engines is included when switch S123 is opened. The button S122 serves handler of the machine as necessary to carry alternatively switching on and off of the circuit for optimum work. Output port A52 is connected to the electric valves Y42 and Y43, which supply with air pneumatic regulators of pumps for injection on fuel on diesel engines.

Let's consider the situation where drilling machines is working under a load. Then switch on servo pressure B51 is closed. When the switch B51 is closed transistor T_{25} is turn on, so its collector is a logical 0. This logical 0 keeps the transistor T_{26} in off position. Its collector is in logical 1. This logical 1 through diode D_{21} resets the decade counter IC_{30} , implemented with the integrated circuit 4017 (all the outputs except Q_0 are logical 0). Logical 0 on the collector of transistor T_{26} is blocking oscillator IC_{28} (no voltage on pin 8). IC_{28} is astable multivibrator realized with the circuit NE555. We said that S123 is open. So, the pin 1 from circuit $IC_{29.A}$, which is one N1I door from circuit 4001, is on a logical 0. The button S122 is not push (located in the cab of the drilling machines). It serves to provide a trigger impulses for the circuit IC_{27} . Circuit IC_{27} is a combination of RS flip floppy and D flip floppy, realized with integrated circuit 4013. With condensates C_{40} and C_{43} provides circuit IC_{27} after the inclusion of voltage to be reset. Thus the output 13 of circuit 4013 has a logical 0.

Because pin 1 and 2 of the circuit $IC_{29.A}$ are logical 0, his output 3 has to be a logical 1. Pin 3 on the circuit $IC_{29.A}$ is connected to the reset input of oscillator-circuit IC_{28} . So at this moment pin 4 the oscillator IC_{28} is the logical 1. It enables oscillator-circuit to work.

On the other hand said that the decade counter IC_{30} is in reset state, so its output Q_9 is logical 0. This logical 0 holds output degree, implemented with transistors T_{27} , T_{28} and relay Re8 in deactivated state. So at this point the output A52 is on 0V. This means that electrical valves Y42 and Y43 are without voltage, so they do not block the supply air to the pneumatic regulators in the pump for injection of fuel to diesel engines. So the final result at this moment is the engines to operate under a full load (maximum speed).

Now we analyze situation when the operator does not give requirement for hydraulic power (handler does not manipulates with command, drilling machines is not loaded). Then switch to the servo pressure B51 is opened. It excludes the transistor T_{25} , whose collector is placed on a logical 1, providing a voltage of pin 8 on oscillator circuit IC_{28} . Because of that the reset pin on oscillator is enabled (logical 1), he begins to oscillate. The output impulses of oscillator acquire on pin 3. the frequency of the outputs impulses is determined by resistor R_{102} and condensate C_{41} .

Frequency is:

$$f = \frac{1}{T}, T = 1.39R_{102}C_{41} \quad (1)$$

for $R_{102} = 720k\Omega, C_{41} = 1\mu F, \Rightarrow T = 1s, f = 1Hz$

Output impulses of oscillator IC_{28} are received by the CLK input of decade counter IC_{30} . On the other hand, a logical 1 at the collector of transistor T_{25} includes the transistor T_{26} , whose collector setting on logical 0 enables reset input (Terminal 15) on the decade counter IC_{30} . So now decade counter IC_{30} can count. It changes the status of its outputs on the front edge of the incoming impulses, pin CLK (14). When will come the front edge on the 9-th impulse, the output Q_9 (pin 11) is setting of logical 1. This logical 1 on the one hand blocks counter IC_{30} , setting its input ENA (pin 13) the logical 1. On the other hand, the logical 1 of pin 11 on IC_{30} the activates the output degree implemented with transistors T_{27} , T_{28} and relay Re8. Consequently A52 output is set on voltage 24V. The appearance of the voltage 24V on pin A52 activates the electric valves Y42 and Y43, which now reduces supply of air for pneumatic regulators of pumps for injection on fuel for



diesel engines. So the final result at this point is reducing on the number of revolutions of the diesel engines to the nominal speed (small gas, idler).

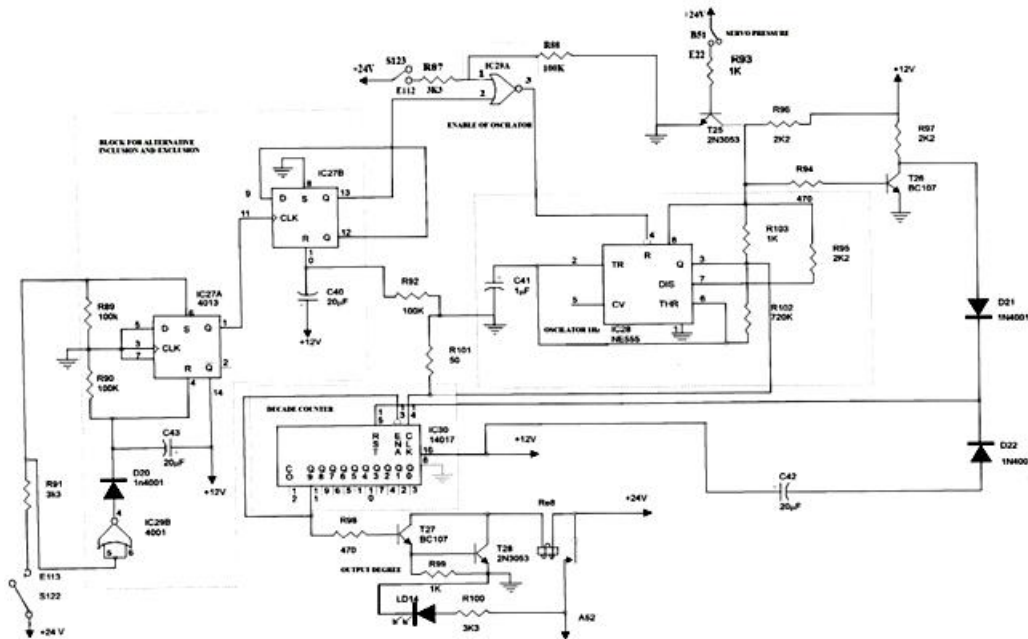

Figure 5. Circuit for optimal operation in the diesel engines

This condition retain until the operator touching one of the commands gives requirement for hydraulic power. As soon as the handler will touch some of the commands, servo switch B51 closes. It includes the transistor T_{25} , whose collector sets on logical 0 blocking oscillator IC_{28} and the transistor T_{26} . The collector of the transistor T_{26} now goes to logical 1 and through diode D_{21} is resetting decade counter and is setting its outputs in a logical 0 (except output Q_0). So now the output degree is deactivate and the output A52 exclude voltage from electrical valves Y42 and Y43. With this supply of air for pneumatic regulators on the pumps for fuel of diesel engines increases. So the engines work with maximum speed again.

Now, to look the work of the circuit IC_{27} . We said that it can alternatively to exclude and include circuit for optimal work. For normal work of the circuit for optimal work of the pin 3 on IC_{29A} have to have a logical 1. That would be, if both its inputs (pin 1 and 2) are logical 0. Another we said that the circuit for optimal work is included when the switch S123 is turned off. Then pin 1 the circuit IC_{29A} have always logical 0. So now setting alternatively pin 2 the circuit IC_{29A} into logical 1 or a logical 0 may be included or excluded the circuit for optimal work. Namely, if the button S122 (located in the cab of the drilling machines) activates once, the input S (6) of the circuit IC_{27} will be set at a logical 1 and the input R (4) in logical 0. It will set the output Q (1) in logical 1. Because this output is input to the CLK pin (11) of the second flip floppy in the circuit IC_{27} , which is connected as a D flip floppy, output Q (13) of the last flip floppy will be set in logical 1. Its logical 1 will cause the output 3 of the circuit IC_{29A} to be placed in a logical 0, which blocks the circuit for optimal work (reset input 4 of the oscillator IC_{28} is a logical 0). Now if the button S122 is pressed again, at the output 1 of the circuit IC_{27} will receive logical 1, which enables circuit for optimal work (reset input 4 of the oscillator IC_{28} is a logical 1). This analyze was made when the switch S123 is opened. If now the switch S123 is closed, we will have a constant logical 1 on input 1 of the circuit IC_{29A} , so that its output 3 will always be logical 0 and the circuit for optimal work is always excluded.



2.2. Simulation of the circuit for optimal work

The configuration of the circuit for simulation is given on figure 6. The simulation is made with PowerSim simulation program [7]. The value of the elements of the figure 6 is the same with the values of elements of the figure 5. The external feedback signal (B51), on the basic of which circuit for optimal work determines whether its output (point 10, or output Q_9 in the IC_{30}), will provides a logical 0 or logical 1, here is simulated with function generator. Generator is connected in the point 19. The frequency of the generator is 0.1Hz.

High level of impulse in point 19, simulates that the machine work with load (motors operate with a maximum speed). Now the circuit for optimal operation is not included.

Low level of impulse on the point 19 (point t_1 in figure 7), simulates that the machine works without a load (motors are working still with maximum speed). In this situation the circuit for optimal work will be included and after a certain time (on the front edge of the 9-th impulse of the oscillator IC_{28} , the moment t_2 the figure 7), its output (point 10) will give a logical 1 (this will cause inclusion of electrical valves Y42 and Y43, which will reduce the supply of air to the pneumatic regulators on pumps for fuel of diesel engines, so engines will reduce number of revolutions). In the figure 6 are given the wave forms of voltage in points 19 (E22), 1 (CLK input of the circuit) and 10 (output Q_9 of circuit IC_{30}).

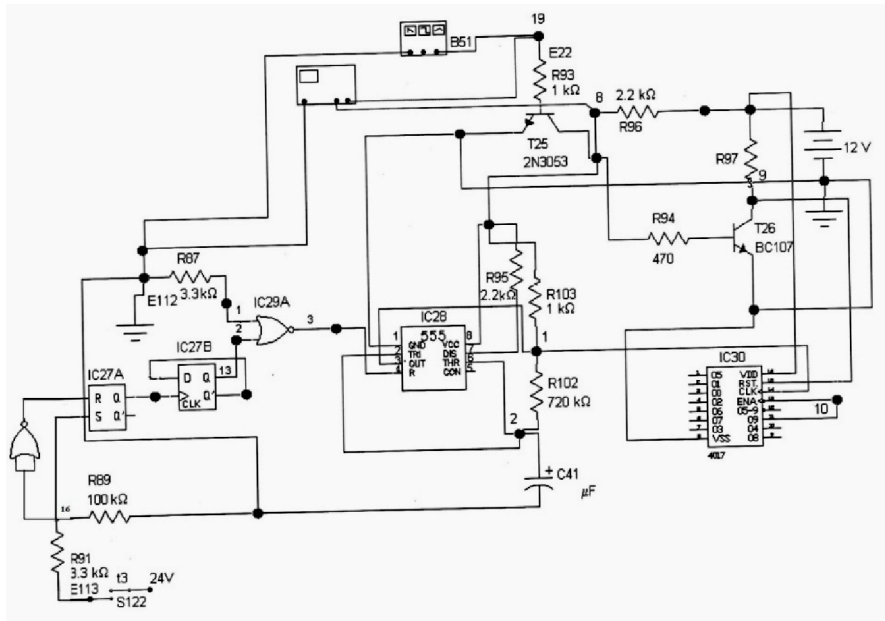

Figure 6. Circuit for simulation

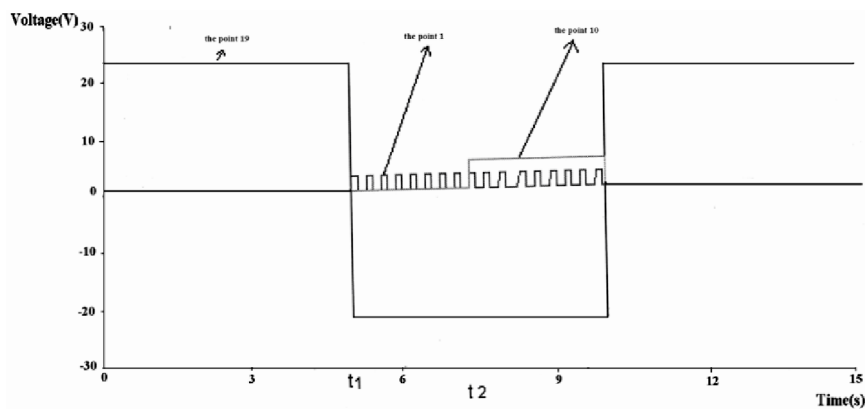

Figure 7. Wave forms of voltage in the points 19, 1 and 10



In the figure 8 is given wave forms of voltage in point 9 (collector on the transistors T_{26}). The transistor T_{26} is BC107 and has $h_{FE} = 300$.

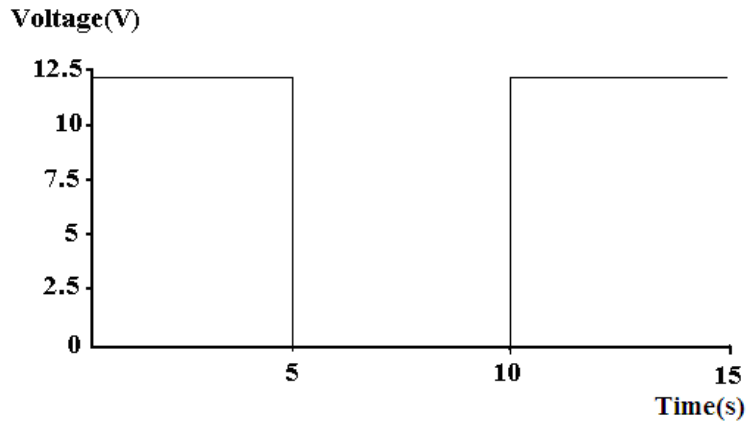

Figure 8. Wave form of voltage in the point 9

In the figure 9 is given wave forms of voltage at the point E113 and pin 4 on circuit IC_{28} . The switch S122 is closed at the moment t_3 (still closed shortly). The appearance of voltage from 24V to point E113, causing the pin 4 on circuit IC_{28} to be set in the logical 0. Its logical 0 blocks the circuit IC_{28} . The circuit IC_{28} remains in this state until the switch S122 will close again (moment t_4). So the switch S122 alternatively blocks and unblocks circuit IC_{28} or the circuit for optimal work includes and excludes.

In the figure 11 are given time diagrams of voltages in some point in the circuit for optimal operation of diesel engines. The time diagram is obtained on the basis of on the results of measurement in different points of the electronic circuit. Measurement is made with oscilloscope and instrument. Comparing the results of measurement and simulation shows that they are identical. Wave forms of voltages in the circuit at simulation coincide with the wave forms of voltages obtained by measurement. The times in the wave forms obtained by simulation and measurement are same.

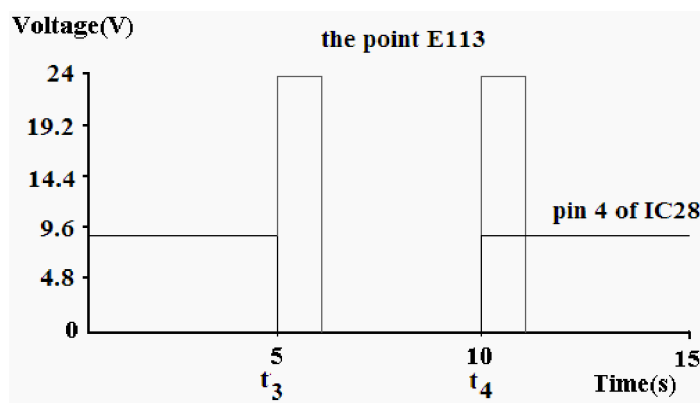

Figure 9. Waves forms of voltage in point E113 and point 4 on circuit IC_{28}

3. EXPERIMENTAL RESULTS

With the experimental results is confirming the theoretical foundations with which is designed the circuit for optimal work of diesel engines of drilling machines [6]. By using the solution are obtain:

- improving the work of diesel engines



- saving up 5-8% fuel
- minimizing of the role of the operator
- optimizing of the overall operation of the drilling machines

In the figure 10 is given a prototype of the circuit for optimal work of the drilling machines, and electronic system for management with the functions of the drilling machines.

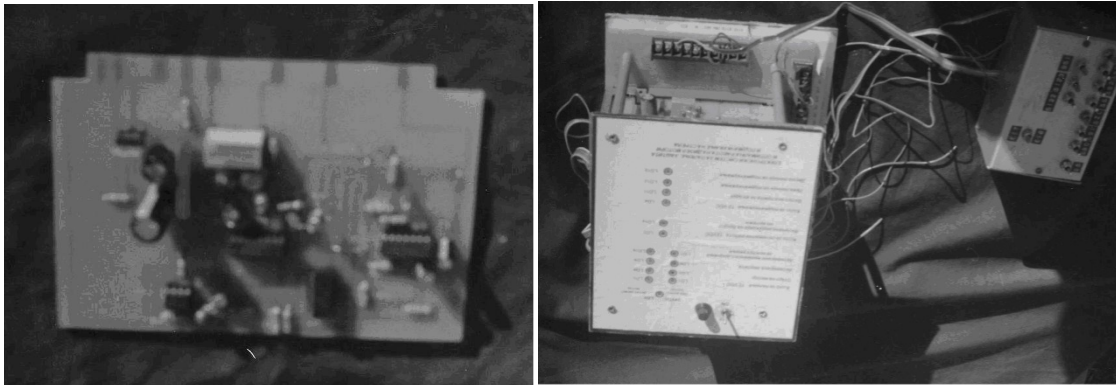

Figure 10. Prototype on circuit for optimal operation and electronic system for management with functions of the hydraulic drilling machines

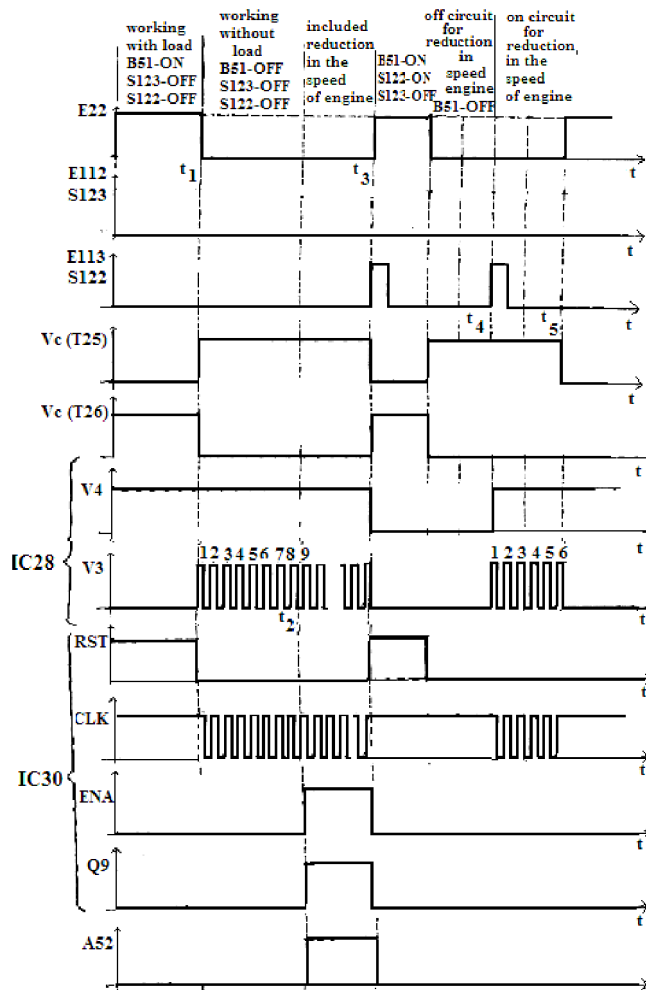

Figure 11. Time diagrams of voltages some point in the circuit for optimal operation of diesel engines at hydraulic drilling machines



4. CONCLUSION

In the paper is done analyze on practical realized solution to the circuit that manages with the work of diesel engines at hydraulic drilling machines implemented for drilling of ore. In the solution are implemented the inclinations of the new developmental directions in mechanics, electricity, hydraulic and electronic in optimization of large mobile work machines. The use of electronic circuit is optimizing the operation of diesel engines so that they work under temperature diagram on the engine given in figure 3. With optimization of diesel engines is optimized and the overall work of the drilling machines. Thus we get the drilling machines to work at any time with revolutions which load is requiring, is minimizing the role of the handler and is saving fuel.

REFERENCES

- [1] D.Shetty, R.A.Kolk, Mechatronics System Design, PWS publishing company, 1997.
- [2] W.Bolton, Mechatronics –Electronic Control Systems in Mechanical Engineering, Longman, 1995.
- [3] R.H.Bishop, The Mechatronics Handbook, CRC Press, 2002.
- [4] M.H.Rashid, Power Electroniccs: Circuit, Devices and Applications,Prentice Hall, 1996.
- [5] M.B.Histand, D.G.Alciaiore, Introduction to Mechatronics and measurement Systems,McGraw-Hill, 2002.
- [6] PowerSim, Simulation programs, 2009.