

Determining optimal distance from outlet of auxiliary forcing ventilation system to development of heading in underground mines

V. Adjiski*, D. Mirakovski, Z. Despodov and S. Mijalkovski

Faculty of Natural and Technical Sciences, Mining Engineering, Goce Delchev University, 2000 Shtip, Macedonia

Received 25 February 2019; received in revised form 27 May 2019; accepted 6 August 2019

Keywords

Underground Mines
Development Heading
Auxiliary Ventilation
CFD
Optimization

Abstract

Auxiliary ventilation of the blind development heading in underground mines is one of the most challenging work activities amongst mining underground operations. The auxiliary forcing ventilation system provides positive pressure, cooling, controlling gas layering, and removing diesel fumes and dust levels from development headings, stopes, and services facilities. The effectiveness of the auxiliary forcing ventilation system depends upon many system variables. Currently, no scientific models and calculations are available that can be used to estimate the optimal distance from the outlet of the auxiliary forcing ventilation system to the development heading in underground mines that can provide the most efficient ventilation close to the face of the heading. In this work, scenarios are developed and simulated with a validated CFD model inside the ANSYS Fluent software. In each scenario, the system parameters such as dead zone, mean age of air, and face velocity are calculated, which are later used in the optimization process. By examining these parameters at the development heading zone, we can quantify the effectiveness of the ventilation system and confirm that the system design meets the government regulations. This work is carried out using the k-epsilon realizable turbulent model inside the ANSYS Fluent software.

1. Introduction

An auxiliary ventilation system must be designed to provide adequate quantities of fresh air to inadequately ventilated workplaces, and make the environment healthy, safe, and comfortable [1]. The auxiliary forcing ventilation system is shown in Figure 1, in which the intake air is led to the face through a duct. This ventilation system is the most commonly used method in underground metal mines since it supplies at high velocity good quality of air to the face, and sends the blasting gases towards the main airway.

All parameters of this auxiliary forcing ventilation system are set by government regulations and empirical formulations in order to provide the required volume of air to be able to dilute and disperse the environment hazards [2, 3].

One of the questionable things in setting up this ventilation system is the distance from the outlet

of the auxiliary forcing ventilation system to the development heading on which to a big extent depends the efficiency of the system itself. Many government regulations and empirical formulations define this distance range from the outlet of the auxiliary forcing ventilation system to the development heading, like [4]:

- distance $L \leq 4\sqrt{S}$ meters from the face, where S is the cross-sectional area of the face in m^2 ;
- distance $L = 30$ duct diameters away from the face;
- distance between 5 m and 12 m, from the face in horizontal headings.

These formulations put the installation of the auxiliary forcing ventilation system to the development heading in the distance range of 5-21 m, and in the absence of an accurate model of

optimal calculation, this distance determination is based only on the user experience, which is not always set correctly.

This paper presents the process of calculating the optimal distance from the outlet of the auxiliary forcing ventilation system to the development heading in underground mines. The ANSYS Fluent software was used for this analysis to solve

complicated airflow problems in three dimensions and to calculate and simulate ventilation parameters like dead zone, mean age of air (MAA), and face velocity at the development heading. The results of these parameters are used for optimization with an algorithm build inside the ANSYS Fluent software.

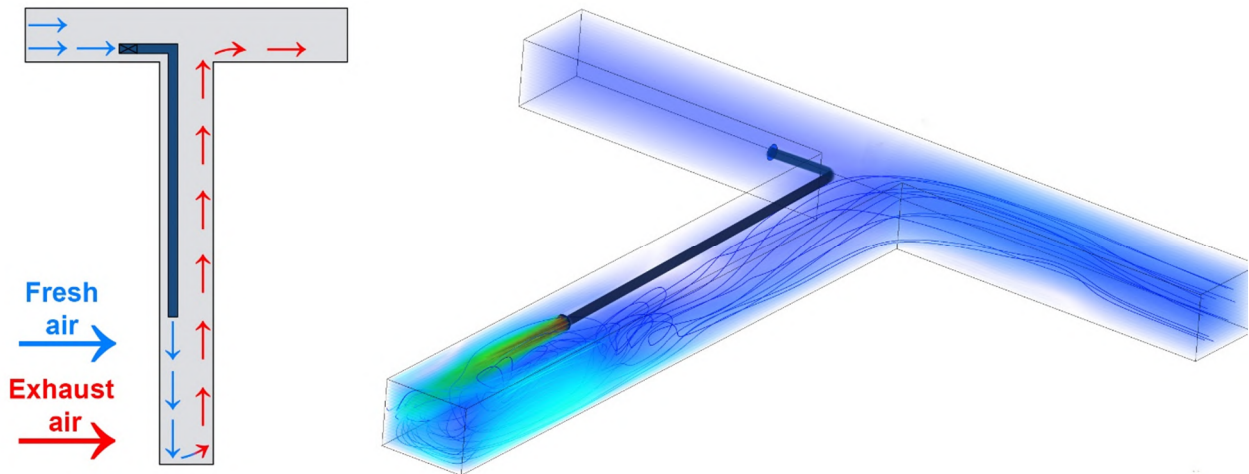

Figure 1. Auxiliary forcing ventilation system in underground mines.

2. Literature review

This section reviews the currently published studies on the application of CFD simulations and calculations for improvements in ventilation systems.

Zhang *et al.* (2011) [5] developed numerical models that analyze the ventilation efficiency of the push-pull ventilation system in underground mines under four different cases using two different criteria: the dead zone analysis and the distribution of local mean ages of air. Both approaches yield similar results.

Park *et al.* (2014) [6] introduced an age-of-air concept such as local mean age (LMA) and local mean residual life time (LMR) as one of the indicators to examine the ventilation efficiency of agricultural facilities by estimating the abilities of fresh air supply and contaminant emission. The idea for estimating LMA and LMR was to solve the passive scalar transport equation in the CFD solver.

Feroze & Genc (2017a) [7] developed CFD models, where scenarios were simulated to analyze airflow rates and patterns at various locations inside the development heading. This research work helped to find the minimum brattice length face distance that should be maintained for each brattice length wall distance to maximize the airflow rate at the face.

Ndenguma *et al.* (2014) [8] carried out a research work that compared the results obtained from an experimental and a numerical study of airflow in a scaled-down underground coal mine model. This research work was done to determine if a numerical analysis was the right tool to search for ventilation solutions in underground coal mines. The data results indicated that numerical modelling was useful in this regard.

Feroze & Genc (2017b) [9] investigated the system variables in underground mine ventilation for forcing and exhausting ducted fan systems in an empty heading using CFD and comparative analyses. Numerical models were developed to calculate the flow rate close to the face of the empty heading for different ventilation system settings. This research work showed that air recirculation for a forcing ducted system could be reduced by increasing the duct diameter or increasing the duct mouth to face distance.

Toraño *et al.* (2006) [10] developed CFD models to simulate airflows in tunnels and galleries and also to make a comparison between these models with the available experimental data. In this research work, the zero equation, k-epsilon, and Spallart-Allmaras models were used, and by comparing their results with the detailed experimental measurements, the results obtained showed a good agreement between the simulated

data and the experimental measurements depending on the turbulence model.

Parra *et al.* (2006) [11] investigated ventilation systems in the development heading of an underground coal mine. The measurements taken in a real mine were used to validate the numerical model. These models provide detailed information about the airflow, MAA, and the methane concentration, which are used to improve the ventilation system efficiency.

Ranjan *et al.* (2013) [12] examined the airflow pattern in a mine ventilation system with the help of CFD modeling. It was concluded that validated CFD modelling could improve the understanding of the airflow patterns in underground mines, and this method could reduce the need of full-scale experiments.

Although most studies have similar objectives, none of them focuses on determining the optimal distance from the outlet of the auxiliary forcing ventilation system to the development heading in underground mines, and in the absence of this method, this installation is based only on the user

experience, which can lead to a poor efficiency of this ventilation system.

3. Methods

3.1. Model formulation

A 3D model was developed to replicate the underground mining region, as shown in Figure 2. The creation of the 3D geometry, meshing, numerical modelling, solving the set of mathematical equations, and optimization and analysis of the results were carried out using the ANSYS Fluent software.

The geometric and operating parameter data shown in Table 1 was set in this work to find the optimal distance from the outlet of the auxiliary forcing ventilation system to the development heading in underground mines.

In order to achieve the necessary accuracy, a structured hexahedral mesh with a size of 0.05 m was created. The mesh size was selected after performing the mesh independence tests, and inflation layers were used at the boundaries of the geometries.

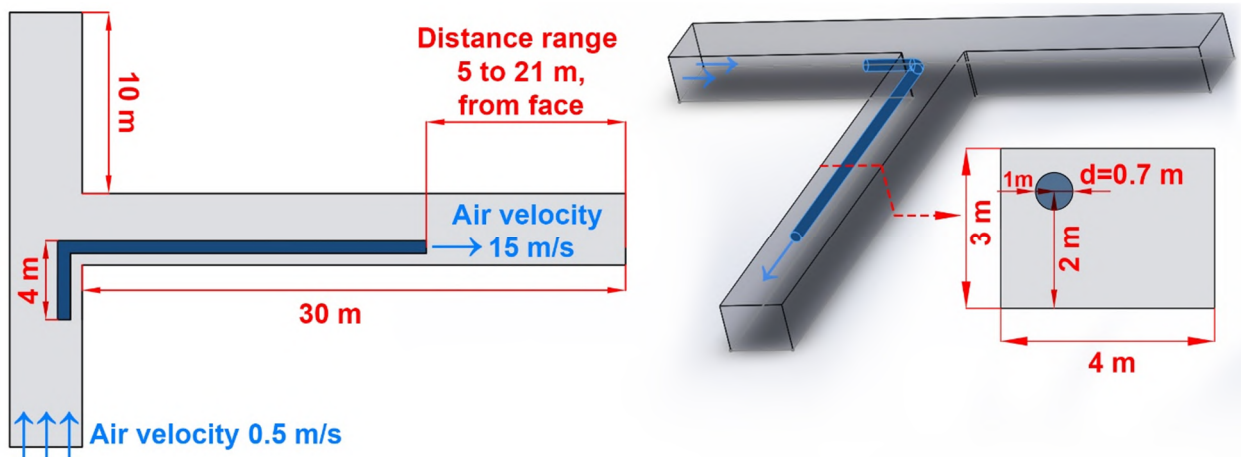

Figure 2. Geometry of the model.

Table 1. Geometric and operating parameters.

Property	Value
Heading length [m]	30
Heading width [m]	4
Heading height [m]	3
Ventilation duct diameter [m]	0.7
Ventilation air velocity [m/s]	15
Ventilation air volume [m ³ /s]	5.8
Distance range from the outlet to the development heading [m]	5 to 21

Velocity inlet boundary conditions were used at the inlet of the mine gallery with the velocity magnitude of 0.5 m/s and at the inlet of the auxiliary forcing ventilation system with the velocity magnitude of 15 m/s. The pressure-outlet boundary conditions were set to the outlet of the

mine gallery and the outlet auxiliary forcing ventilation system with the gauge pressure of 0 Pa. A wall boundary condition was used for all the walls, and no slip condition was set along the walls and ducts. The boundary condition for the age of air was set to zero at the inlets. A

convergence criterion of the order of 10^{-5} was used in all of the numerical simulations. The solution was calculated using a second-order scheme. The steady conservation equations for mass and momentum done in the ANSYS Fluent software were as follow [13]:

$$\frac{\partial \rho}{\partial t} + \nabla^* (\rho \vec{v}) = 0 \tag{1}$$

$$\frac{\partial}{\partial t} (\rho \vec{v}) + \nabla^* (\rho \vec{v} \vec{v}) = -\nabla p + \rho \vec{g} + \vec{F} \tag{2}$$

where ρ is the density, t is the time, \vec{v} is the overall velocity vector, p is the static pressure, and $\rho \vec{g}$ and \vec{F} are the gravitational body force and external body forces, respectively.

There are four commonly used turbulence models in the ANSYS Fluent software including the Reynolds Stress, Spallart-Almaras, k-epsilon, and k-Omega models [13]. The realizable k-epsilon model was used for this experiment because in the previous research works it was found to be sufficient [14-16]. This turbulence model is based on the transport equations for the turbulence kinetic energy (k) and its dissipation rate (ϵ). The realizable k-epsilon model contains an alternative formulation for the turbulent viscosity and modified transport equation for the dissipation rate (ϵ). The realizable k-epsilon modeled transport equations for k and ϵ are as follow [13]:

$$\frac{\partial}{\partial t} (\rho k) + \frac{\partial}{\partial x_j} (\rho k u_j) = \frac{\partial}{\partial x_j} \left[\left(\mu + \frac{\mu_t}{\sigma_k} \right) \frac{\partial k}{\partial x_j} \right] + G_k + G_b - \rho \epsilon - Y_M + S_k \tag{3}$$

$$\begin{aligned} \frac{\partial}{\partial t} (\rho \epsilon) + \frac{\partial}{\partial x_j} (\rho \epsilon u_j) &= \frac{\partial}{\partial x_j} \left[\left(\mu + \frac{\mu_t}{\sigma_\epsilon} \right) \frac{\partial \epsilon}{\partial x_j} \right] \\ &+ \rho C_1 S \epsilon - \rho C_2 \frac{\epsilon^2}{k + \sqrt{v \epsilon}} \\ &+ C_{1\epsilon} \frac{\epsilon}{k} C_{3\epsilon} G_b + S_\epsilon \end{aligned} \tag{4}$$

where:

$$C_1 = \max \left[0, 43, \frac{\eta}{\eta + 5} \right], \eta = S \frac{k}{\epsilon}, S = \sqrt{2 S_{ij} S_{ij}} \tag{5}$$

G_k represents the generation of turbulence kinetic energy due to the mean velocity gradient, G_b is the generation of turbulence kinetic energy due to buoyancy, Y_M represents the contribution of the

fluctuating dilatation in compressible turbulence to the overall dissipation rate, C_2 and $C_{1\epsilon}$ are constants, σ_k and σ_ϵ are the turbulent Prandtl numbers for k and ϵ , S_k and S_ϵ are the user-defined source terms, x_j is the axial coordinate, and u_j is the axial velocity.

The value for MAA was calculated by solving the passive scalar transport equation in the ANSYS Fluent software, as follows [13]:

$$\frac{\partial}{\partial x_i} \rho u_i \phi - \vec{J} \frac{\partial \phi}{\partial x_i} = \rho \tag{6}$$

\vec{J} is the component of diffusion flux.

MAA is an important index of evaluating the confined space environment, defined as the average time that air has spent in a zone and accumulating contaminants [17, 18]. Since there is no available model in the ANSYS Fluent software for calculating the mean age of air, the equation is embedded in the CFD simulation using the user-defined functions (UDF), which are developed in a separate code and then compiled into executable functions in the solver, as shown in Figure 3. An energy equation is not included in this simulation because heat transfer is ignored.

3.2. Optimization method

The optimization technique used in this work is the response surface optimization from the design exploration module. The response surface optimization can generate a graphical representation that allows locating and seeing how changes to each input parameter affect a selected output parameter [19]. The MOGA (Multi-Objective Genetic Algorithm) option is used in the response surface optimization. MOGA is a hybrid variant of the non-dominated sorted genetic algorithm-II [20]. It supports all types of the input parameters, and the Pareto ranking scheme is done by a fast non-dominated sorting method. When the MOGA optimization method is used, the search algorithm uses the objective properties of the output parameters and ignores the similar properties of the input parameters. When the candidate designs are reported, they are filtered through a decision support process that applies the parameter optimization objectives and reports the three best candidate designs [21]. The optimization domain of the input parameters and the optimization objective and constraints for the response surface optimization done in this work are shown in Figure 4.

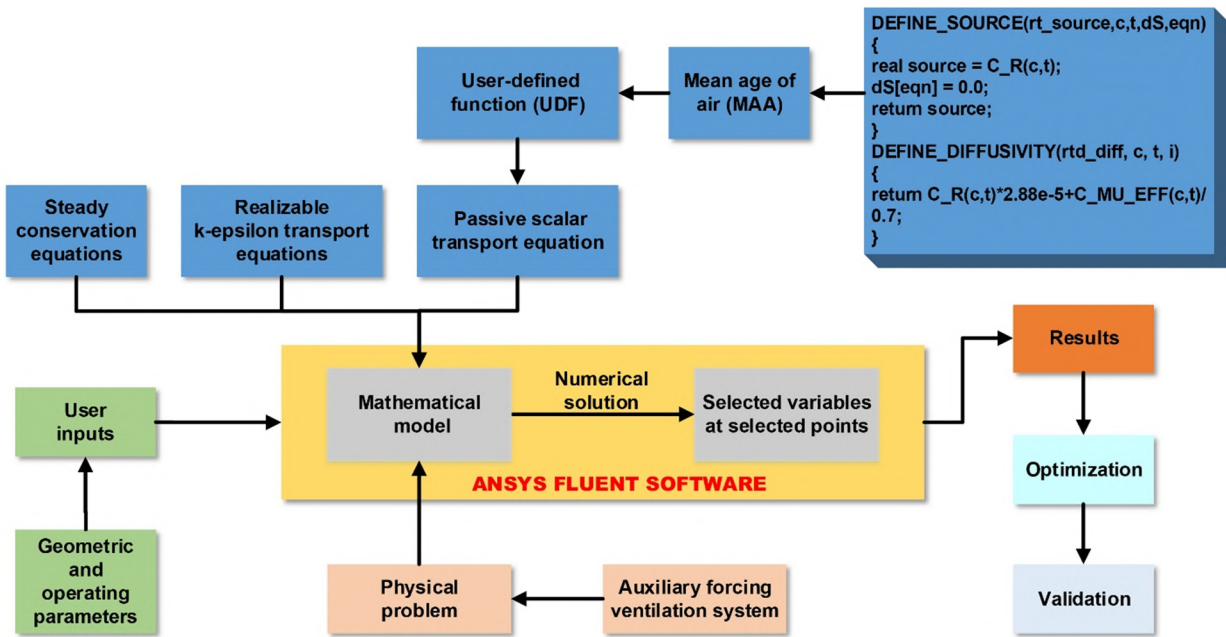

Figure 3. Calculation steps of the proposed methodology.

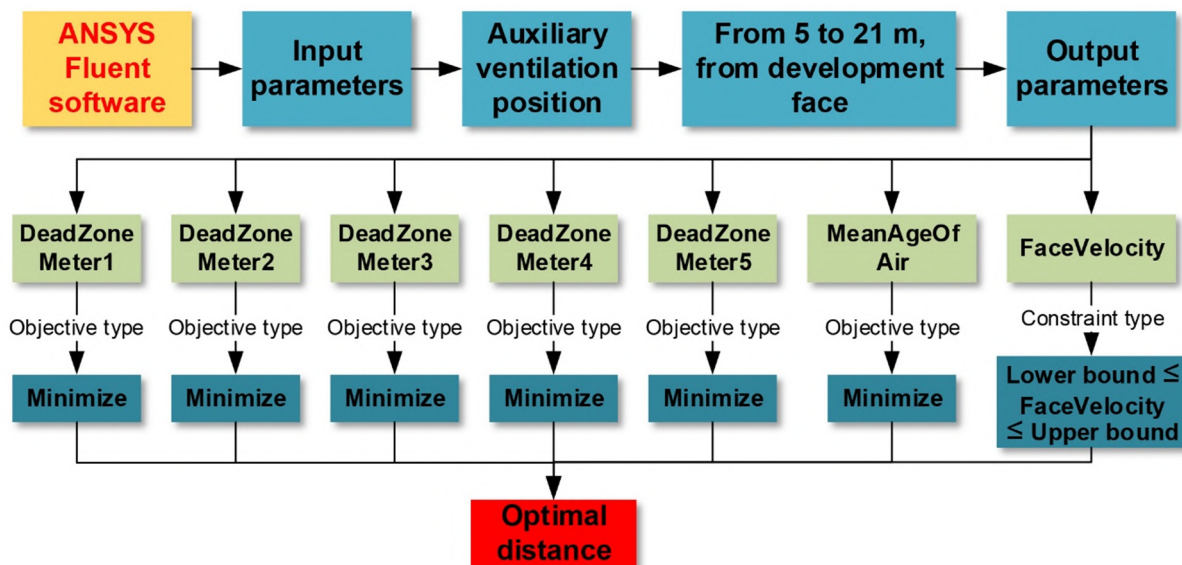

Figure 4. Optimization process.

4. Results and discussion

4.1. Numerical results

In this work, a total of 11 numerical simulation scenarios were explored under the same geometric and operating parameters, where the distance range from the outlet of the auxiliary forcing ventilation system to the development heading varied from 5 to 21 m. Table 2 illustrates the results of the numerical simulation scenarios with respect to their specific distance from the outlet to the development heading. The flow of air, dead zone, face velocity, and MAA inside the volume of the heading were shown and calculated using the cut-plane contours inside the ANSYS Fluent software (Figure 5).

Figures 6 and 7 show the velocity distribution at the mining face for all numerical simulation scenarios including the data between the values that are generated from the response surface optimization inside the ANSYS Fluent software. With increase in the air ventilation velocity, the larger dust particles will not be diluted proportionally, and as the ventilation velocity increases, these dust particles will remain airborne for longer distances before settling out [22]. The respirable dust settles from the air ventilation flow at an almost negligible rate, and should be controlled via dilution. In the case of larger dust particles, it is primarily the air ventilation velocity that directs the distance and time for which the

dust particles remain airborne in the air stream. If the air ventilation velocity is too big, then additional dust particles can be picked up by the air stream that reduces the quality of the air in the ventilated place. The effects of those parameters have been studied by McPherson (1993) [1], and from there, we will set the constraints for face velocity in which we will consider the limits for the lower bound air velocity of 1.2 m/s and for the upper bound air velocity of 3 m/s. This set of constraints is for the minimum total dust concentration and the best sorting and dispersal effect of air velocity on dust particles. Many government regulations on mining safety establish that the ventilation system should guarantee a healthy and comfortable environment during operation with the minimum air velocity

value at 0.3 m/s [5]. The regions where air velocity remains under this value are defined as the dead zones. As mining working activities are performed throughout the mine, this dead zone region shows the biggest pollutants' concentration [23]. In order to make the underground environment suitable for mine workers, a right air renewal should be chiefly ensured at these zones. By investigation of the dead zone areas, it is possible to evaluate the air quality of a ventilation system.

Figures 8 and 9 show the dead zone percentages in every cross-section with respect to the distance from the outlet to the development heading. In the response surface optimization module, the objective type for every dead zone is set to filter the minimum value (Figure 4).

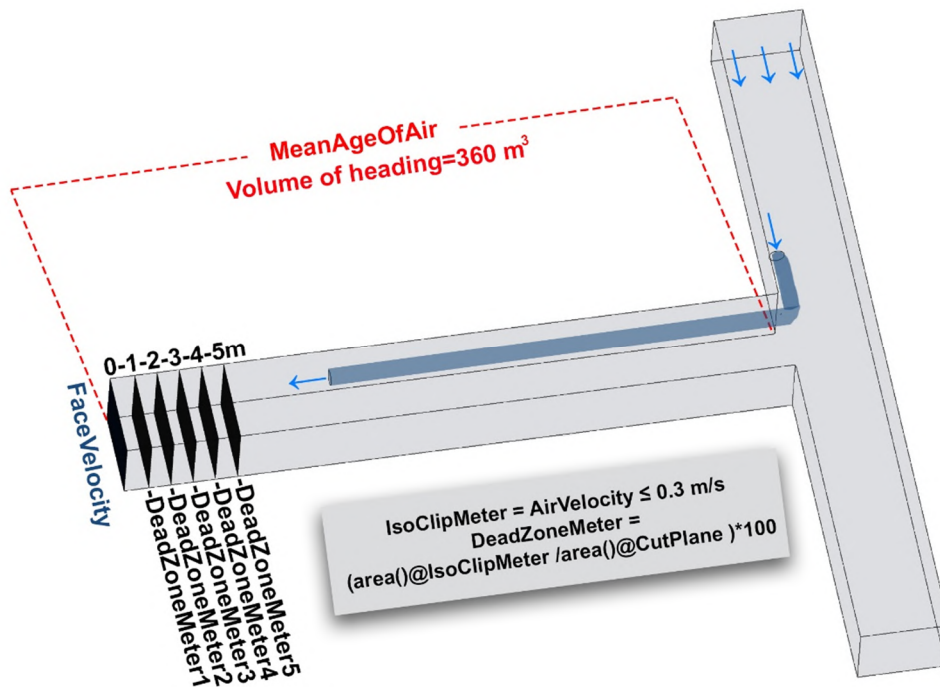

Figure 5. Locations for the output parameters.

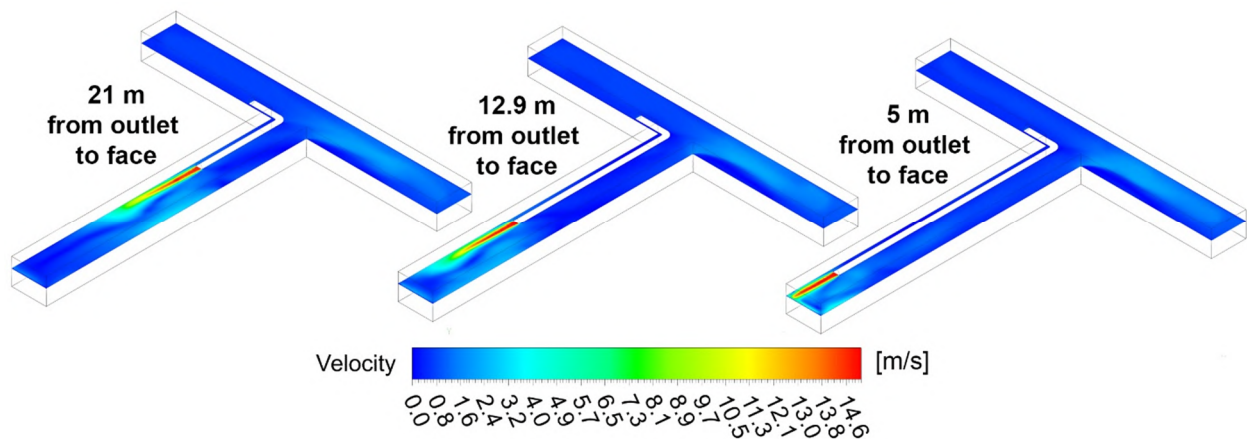

Figure 6. Velocity contours for different outlet locations.

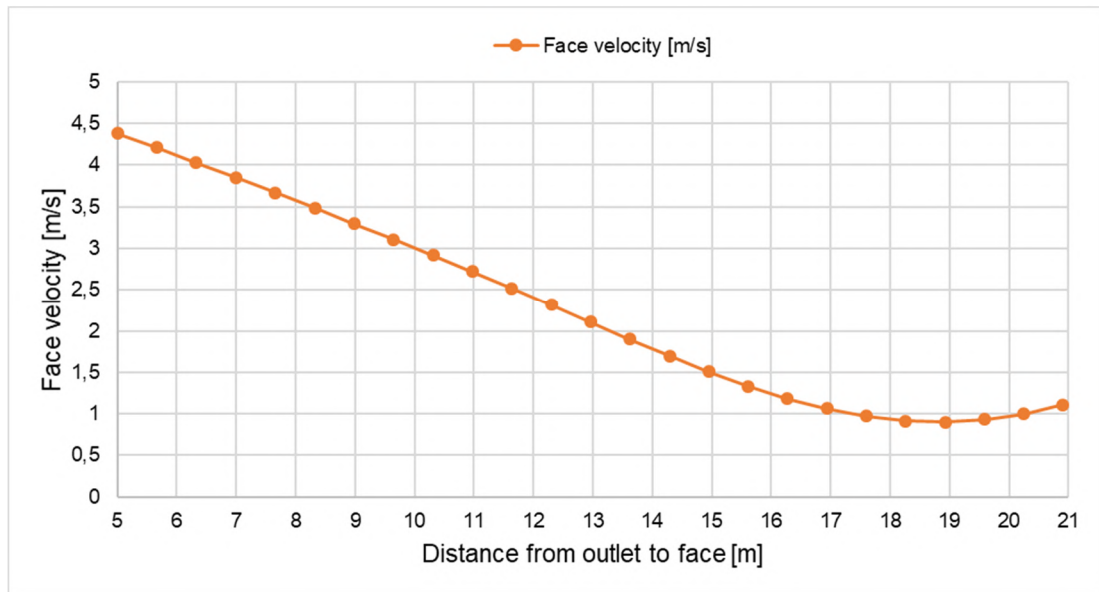

Figure 7. Average value of face velocity with respect to the distance from the outlet to the development heading.

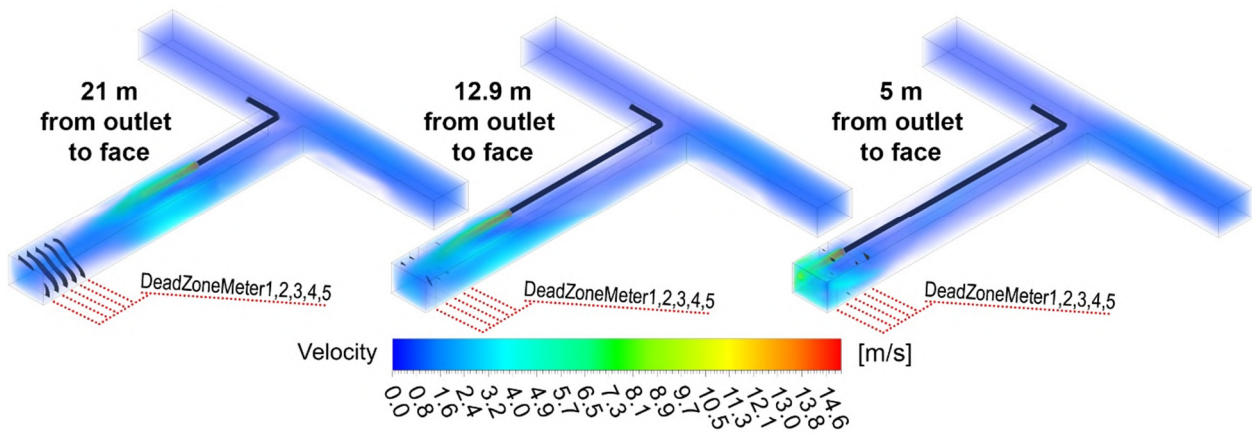

Figure 8. Dead zone areas for different outlet locations.

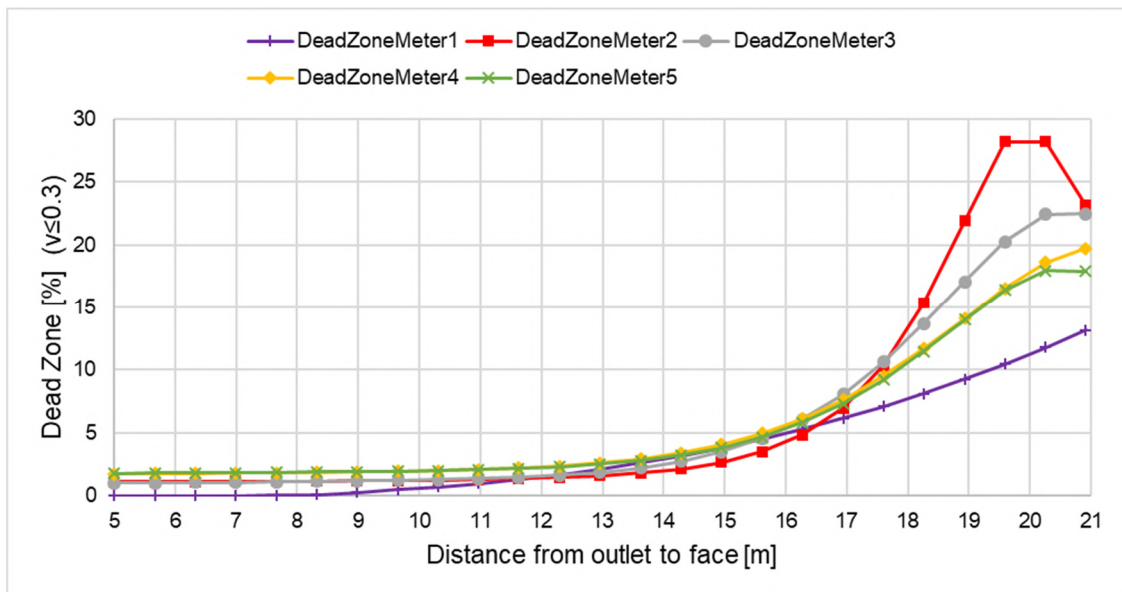

Figure 9. Dead zone areas with respect to the distance from the outlet to the development heading.

Sometimes ventilation quality based on determining the dead zone areas may not be appropriate since air velocities can be over the required value by law because of the air recirculation, and because of this, the quality of air may not meet the government regulations [24]. Furthermore, the introduction of MAA to the study can tighten the efficiency of the ventilation system. Figures 10 and 11 show MAA inside the volume of the development heading for different outlet locations. In the response surface optimization module, the objective type for MAA is set to filter the minimum value (Figure 4). Once the numerical simulation scenarios are explored, the next step is to optimize the design model. The response surface optimization method used in this work requires that the design point results are generated before the optimization. These design points were determined using the

design of experiments method, and the results obtained were tabulated in Table 2.

The design of experiments method is used to build a statistical model in order to predict the responses from the model. The response surface functions are fit to the analysis data and serve as a surrogate model of the design (Figures 7, 9, and 11). The optimization algorithm samples the data in search for the optimum design in conjunction with the objective and constraint type, and reports the three best candidate designs shown in Table 3.

The candidate point 1 has the best rating, which is the optimal distance from the outlet of the auxiliary forcing ventilation system to the development heading for this underground ventilation model. Figure 12 shows a visual representation of the optimal solution for the model.

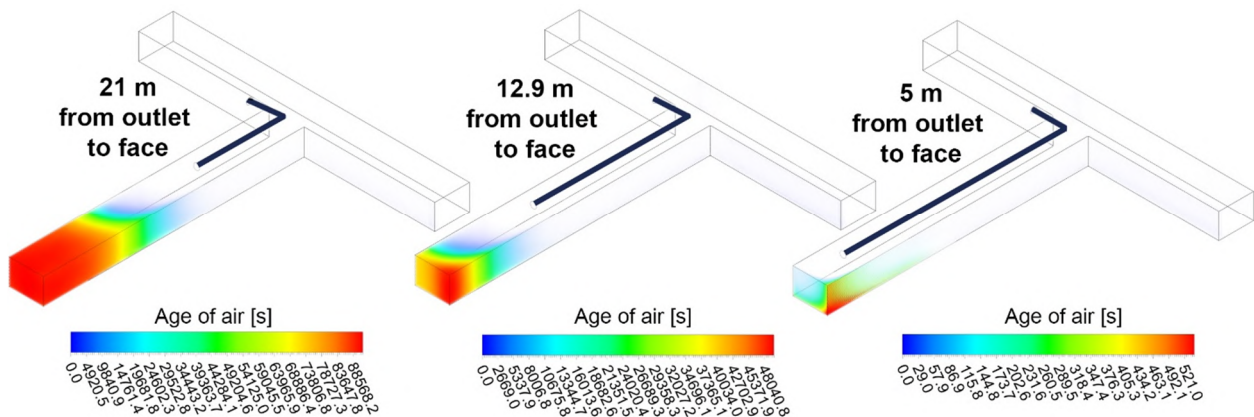

Figure 10. MAA inside the volume of the development heading for different outlet locations.

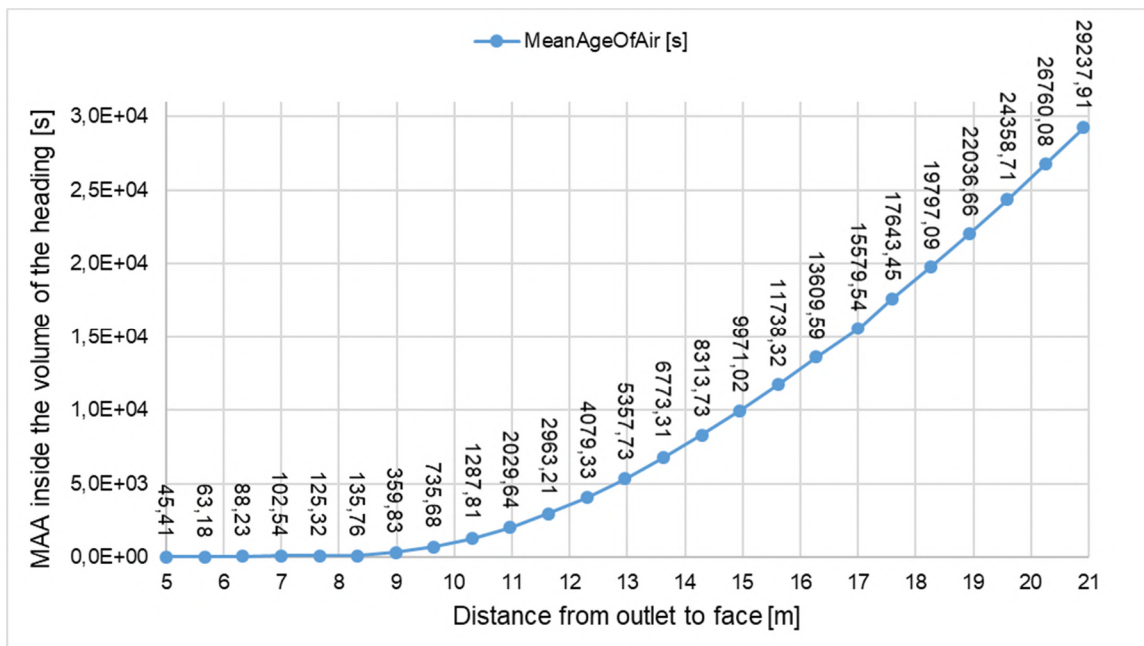

Figure 11. MAA with respect to the distance from the outlet to the development heading.

Table 2. Results of the numerical simulation scenarios with respect to their specific distance from the outlet to the development heading.

Distance from outlet to face [m]	Dead Zone Meter1 [%]	Dead Zone Meter2 [%]	Dead Zone Meter3 [%]	Dead Zone Meter4 [%]	Dead Zone Meter5 [%]	Face Velocity [m/s]	Mean Age Of Air [s]
21	10.67	23.20	21.09	18.32	16.10	1.11	30114.50
19.3	17.13	25.84	22.56	19.86	21.20	0.98	21861.50
17.7	3.41	13.17	13.80	10.36	10.47	1.22	17986.60
16.1	9.12	2.11	0.81	0.55	1.13	0.82	13747
14.5	0.39	3.90	5.81	7.80	3.78	2.09	9847.49
12.9	1.24	3.14	0.57	1.44	2.71	1.70	4574.42
11.3	0.30	1.38	1.14	1.35	3.53	2.43	2077.60
9.7	0.20	1.34	0.67	0.99	0.35	3.31	666.94
8.1	0.16	0.59	2.15	6.50	5.55	4.01	214.07
6.5	0.34	1.19	1.01	1.84	1.08	4.02	81.96
5	0.16	0.90	3.07	1.38	2.81	4.16	45.40

Table 3. Best ranged candidate points from the optimization process.

	Candidate Point 1 [RANG 1]	Candidate Point 2 [RANG 2]	Candidate Point 3 [RANG 3]
Distance from outlet to face [m]	10.8998	10.8918	10.8816
DeadZoneMeter1 [%]	0.6508	0.6538	0.65768
DeadZoneMeter2 [%]	1.2479	1.2484	1.24904
DeadZoneMeter3 [%]	1.2731	1.2739	1.27500
DeadZoneMeter4 [%]	2.0013	2.0022	2.00326
DeadZoneMeter5 [%]	2.0109	2.0116	2.01254
FaceVelocity [m/s]	2.9838	2.9815	2.97853
MeanAgeOfAir [s]	1098.8117	1105.9333	1115.001

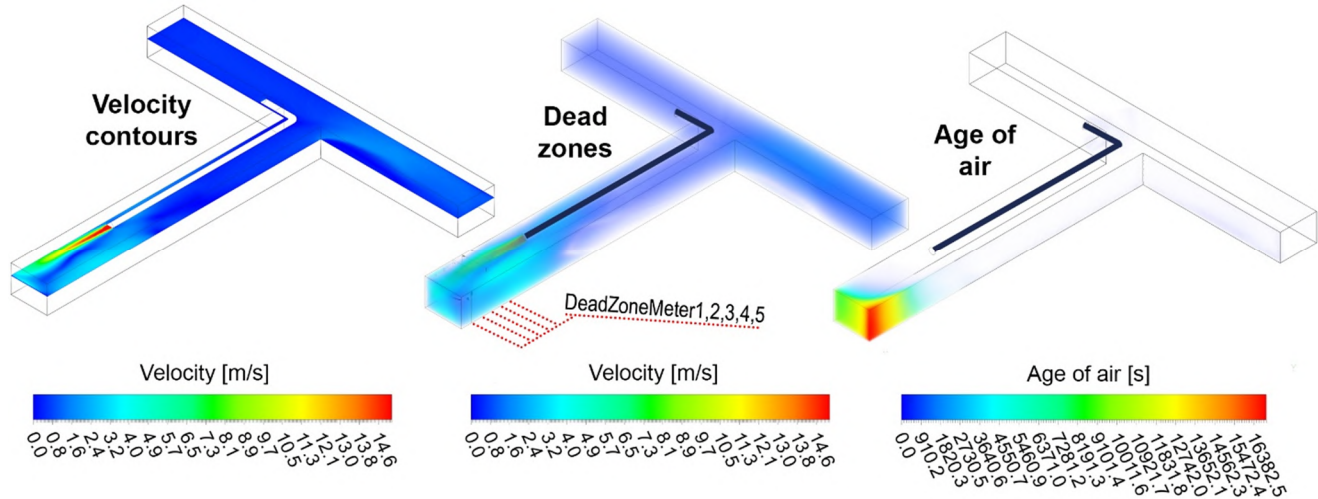

Figure 12. CFD simulation of the calculated optimal distance from the outlet of the auxiliary forcing ventilation system to the development heading (Candidate Point 1).

4.2. Validation results

For validating the model, the experimental measurements of the auxiliary forcing ventilation system in the development heading are required. The numerical model used in this work was validated using an experimental study carried out by Feroze and Genc (2017) [9]. The authors used this experimental data to validate their model at several points on a vertical plane at a distance of 0.5 m from the face of the development heading.

For the purpose of the validation process of this work, we only changed the heading 3D geometry and the air velocity of 10.08 m/s at the exit of the duct to match the experimental study done by Feroze and Genc (2017) [9] (Figure 13). The meshing, numerical modeling, and solving the set of mathematical equations were left the same as the previous model set-up. Figure 14 gives a comparison between the numerical simulation results with the

experimental results. This comparison shows that the numerical results are in good line with the experimental results. The velocities of the air in the experimental study are marked with a positive sign towards the face

and with a negative sign after sweeping the face of the tunnel. This procedure for reading the air velocities in selected measurement points is also used in the CFD validation model, as can be seen from the velocity contours in Figure 15.

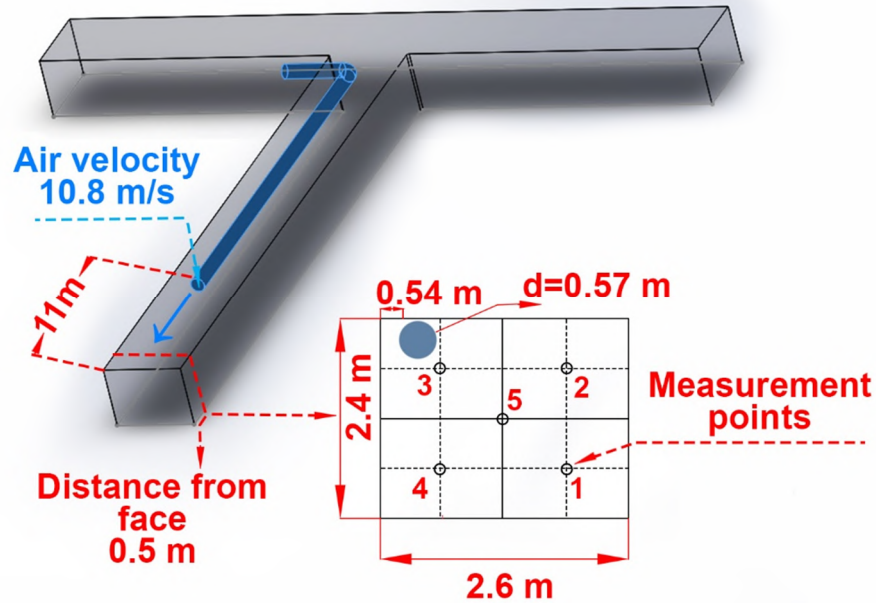

Figure 13. Set-up of geometry and measurement points to match the experimental study.

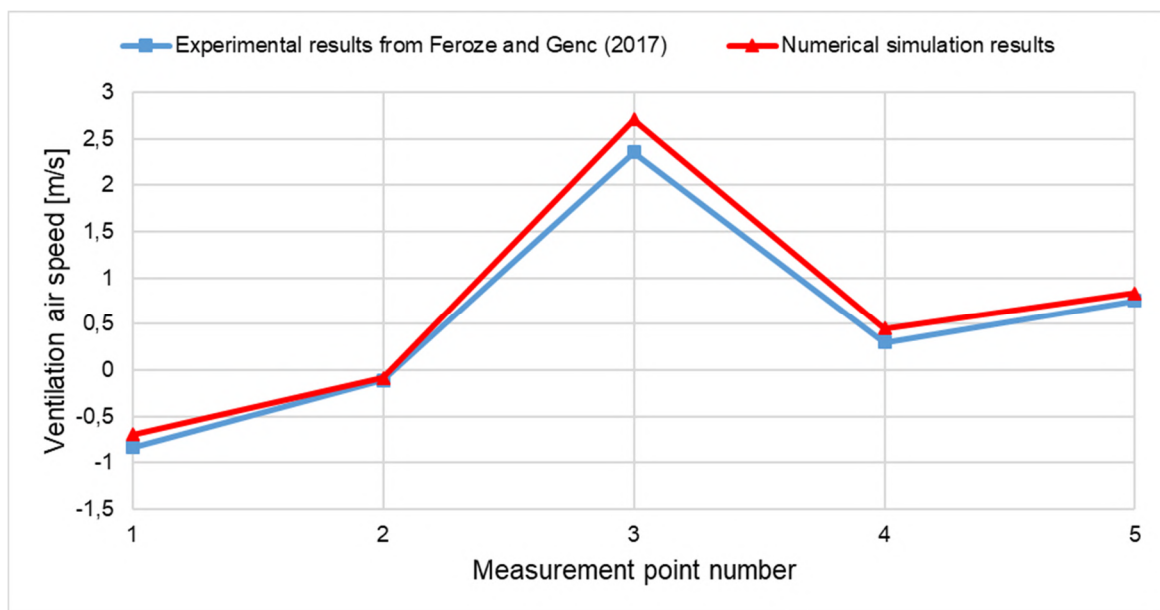

Figure 14. Comparison of the ventilation air speed in the selected measurement points between the numerical results and the experimental results.

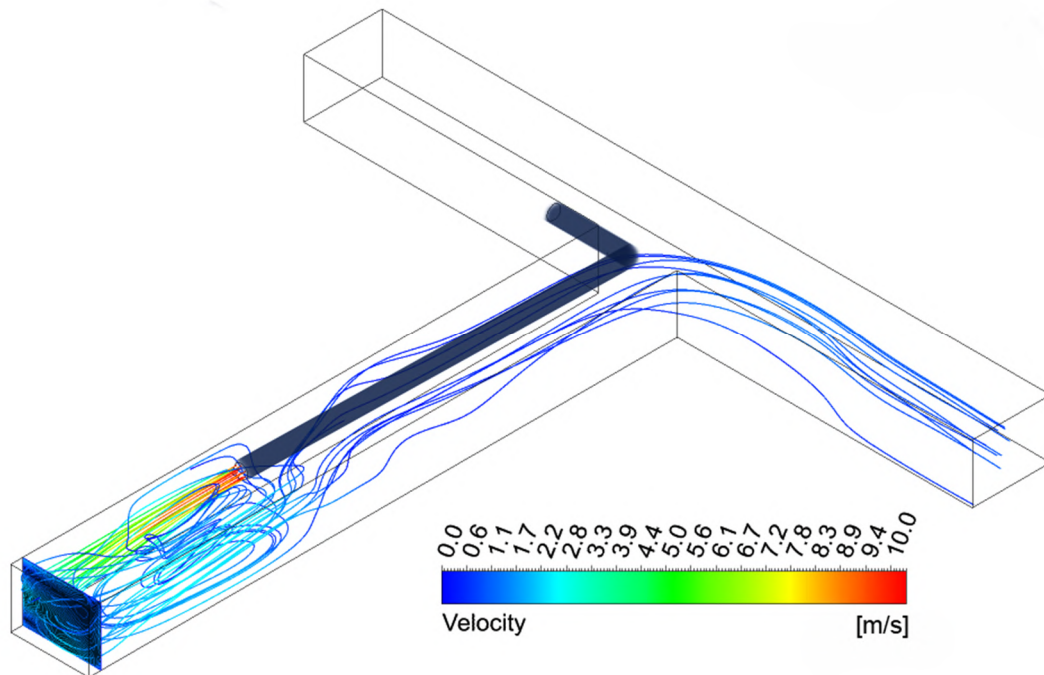

Figure 15. CFD simulation from the validation model.

5. Conclusions

The methodology for calculating the optimal distance from the outlet of the auxiliary forcing ventilation system to the development heading in underground mines was introduced in this research work. The 3D validated CFD model for an auxiliary forcing ventilation system in the development heading was constructed and presented. In order to take into account the turbulence effect, k-epsilon realizable turbulent model inside the ANSYS Fluent software was used, and the results for 11 numerical simulation scenarios were presented. The proposed methodology for calculating the optimal solution of the problem uses the quality and efficiency of the auxiliary forcing ventilation system under three different parameters: face velocity, dead zone areas, and MAA inside the volume of the heading. In all of the numerical simulation scenarios presented in this paper, these parameters were calculated with respect to the specific distance from the outlet to the development heading. The optimized solution aids to minimize the dead zone areas and MAA inside the face velocity constraints that will provide minimum total dust concentration and the best sorting and dispersal effect on dust particles at the development heading. This methodology offers a systematic approach to solve a problem, the installation of which is based only on the user experience without any prior calculation based on scientific research. The results of this research

work not only improve the efficiency of the auxiliary forcing ventilation system but also reduce the energy costs and provide a better work environment for every underground miner.

Acknowledgments

This work was financially supported by the Faculty of Natural and Technical Sciences–Mining Engineering, “Goce Delchev” University, Shtip, R.N. Macedonia.

References

- [1]. McPherson, M.J. (1993). *Subsurface Ventilation and Environmental Engineering*, Chapman & Hall, London. pp. 21-25
- [2]. Mirakovski, D. and Krstev, B. (2000). Design process and equipment selection for auxiliary ventilation systems, *Proceedings of the Ninth International Symposium on Mine Planning and Equipment Selection*, A.A. Balkema, Rotterdam. pp. 89-93.
- [3]. Lee, D.K. (2017). Evaluation of the optimum conditions for a local ventilation system in connection with the mine ventilation network. in M Hudyma & Y Potvin (eds), *Proceedings of the First International Conference on Underground Mining Technology*, Australian Centre for Geomechanics, Perth. pp. 655-661.
- [4]. De Souza, E. (2004). Auxiliary ventilation operation practices. In: Ganguli R, Bando-padhyay S, eds. *Proceedings of the 10th U.S./North American*

Mine Ventilation Symposium. Leiden, Netherlands: Balkema. pp. 341-348.

[5]. Zhang, X., Zhang Y. and Tien, J.C. (2011). The Efficiency Study of the Push-pull Ventilation System in Underground Mine, 11th Underground Coal Operators' Conference, University of Wollongong & the Australasian Institute of Mining and Metallurgy. pp. 225-230.

[6]. Park, S., Lee, I. and Hong, S. (2014). New Development of a Straightforward Method of Estimating Age-of-Air Using CFD. *Acta Horticulturae*. 1037: 963-969.

[7]. Feroze, T. and Genc, B. (2017). Evaluation of line brattice length in an empty heading to improve air flow rate at the face using CFD. *International Journal of Mining Science and Technology*. 27 (2): 253-259.

[8]. Ndenguma, D.D., Dirker, J. and Burger, N.D.L. (2014). A computational fluid dynamics model for investigating air flow patterns in underground coal mine sections. *The Journal of the Southern African Institute of Mining and Metallurgy*. 114 (6): 419-425.

[9]. Feroze, T. and Genc, B. (2017). Analysis of the effect of ducted fan system variables on ventilation in an empty heading using CFD. *Journal of the Southern African Institute of Mining and Metallurgy*. 117 (2): 157-167.

[10]. Toraño, J., Rodríguez, R. and Diego, I. (2006). Computational Fluid Dynamics (CFD) use in the simulation of the death end ventilation in tunnels and galleries. *WIT Transactions on Engineering Sciences*. 52: 113-121.

[11]. Parra, M.T., Villafruela, J.M., Castro, F. and Méndez, C. (2006). Numerical and experimental analysis of different ventilation systems in deep mines. *Building and Environment*. 41 (2): 87-93.

[12]. Ranjan, M., Kumar, K. and Ghosh, S. (2013). Mine Ventilation in a Bord and Pillar Mines Using Cfd. *International Journal of Emerging Technology and Advanced Engineering*. 3 (3): 389-393.

[13]. Ansys Academic Research. (2015). ANSYS Fluent Theory Guide, Release 15.0, Help System, Chapter 4, pp.39-177.

[14]. Branny, M., Karch, M., Wodziak, W., Jaszczur, M., Nowak, R. and Szmyd, J.S. (2014). An experimental validation of a turbulence model for air flow in a mining chamber. *Journal of Physics: Conference Series*. 530 (1): 1-8.

[15]. Fang, Y., Fan, J., Kenneally, B. and Mooney, M. (2016). Air flow behavior and gas dispersion in the recirculation ventilation system of a twin-tunnel construction. *Tunnelling and Underground Space Technology*. 58: 30-39.

[16]. Ndenguma, D.D., Dirker, J. and Burger, N.D.L. (2014). A computational fluid dynamics model for investigating air flow patterns in underground coal mine sections. *The Journal of the Southern African Institute of Mining and Metallurgy*. 114: 419-425.

[17]. Sereshki, F., Saffari, A. and Elahi, E. (2016). Comparison of Mathematical Approximation Methods for Mine Ventilation Network Analysis. *International Journal of Mining Science (IJMS)*. 2 (1): 1-14.

[18]. Adjiski, V., Mirakovski, D., Despodov, Z. and Mijalkovski, S. (2018). Method for determining the air change effectiveness of the auxiliary forcing ventilation system, *Mining Science*. 25: 175-192.

[19]. Winne, S.J. and Chandrasekaran, M. (2015). Optimization of Nozzle: Convergence Using Ansys with RSM, MOGA. *ARPN Journal of Engineering and Applied Sciences*. 10: 5486-5489.

[20]. Grebenişan, G. and Salem, N. (2017). The multi-objective genetic algorithm optimization, of a superplastic forming process, using ansys. *MATEC Web of Conferences*. 126 :1-7.

[21]. Knowles, J. and Corne, D. (1999). The Pareto archived evolution strategy: a new baseline algorithm for Pareto multiobjective optimization, *Proceedings of the 1999 Congress on Evolutionary Computation-CEC99 (Cat. No. 99TH8406)*, Washington, DC, 105-112. doi: 10.1109/CEC.1999.781913

[22]. Toraño, J., Torno, S., Menéndez, M. and Gent, M. (2011). Auxiliary ventilation in mining roadways driven with roadheaders: Validated CFD modelling of dust behaviour. *Tunnelling and Underground Space Technology*. 26 (1): 201-210.

[23]. Sasmito, A.P., Birgersson, E., Ly, H.C. and Mujumdar, A.S. (2013). Some approaches to improve ventilation system in underground coal mines environment - A computational fluid dynamic study. *Tunnelling and Underground Space Technology*. 34: 82-95.

[24]. Park, J., Park, S. and Lee, D.K. (2016). CFD modeling of ventilation ducts for improvement of air quality in closed mines. *Geosystem Engineering*. 19 (4): 177-187.

Determining optimal distance from outlet of auxiliary forcing ventilation system to development of heading in underground mines

V. Adjiski*, D. Mirakovski, Z. Despodov and S. Mijalkovski

Faculty of Natural and Technical Sciences, Mining Engineering, Goce Delchev University, 2000 Shtip, Macedonia

ارسال ۲۰۱۹/۲/۲۵، پذیرش ۲۰۱۹/۸/۶

* نویسنده مسئول مکاتبات: vanco.adjiski@ugd.edu.mk

Abstract:

Auxiliary ventilation of the blind development heading in underground mines is one of the most challenging work activities amongst mining underground operations. The auxiliary forcing ventilation system provides positive pressure, cooling, controlling gas layering, and removing diesel fumes and dust levels from development headings, stopes, and services facilities. The effectiveness of the auxiliary forcing ventilation system depends upon many system variables. Currently, no scientific models and calculations are available that can be used to estimate the optimal distance from the outlet of the auxiliary forcing ventilation system to the development heading in underground mines that can provide the most efficient ventilation close to the face of the heading. In this work, scenarios are developed and simulated with a validated CFD model inside the ANSYS Fluent software. In each scenario, the system parameters such as dead zone, mean age of air, and face velocity are calculated, which are later used in the optimization process. By examining these parameters at the development heading zone, we can quantify the effectiveness of the ventilation system and confirm that the system design meets the government regulations. This work is carried out using the k-epsilon realizable turbulent model inside the ANSYS Fluent software.

Keywords: Underground Mines, Development Heading, Auxiliary Ventilation, CFD, Optimization.
