

DEPENDENCE OF THE ACTIVE POWER OF THE SERIAL RESONANT BRIDGE CONVERTER FROM THE PHASE DIFFERENCE AND THE DUTY CYCLE

Assist. prof. Dr. Eng. Stefanov G.¹, Prof. Dr. Eng. Karadinov Lj.², Assos. prof. Dr. Eng. Sarac V.³, Prof. Dr. Eng. Atanasova-Pacemska T.⁴, Assist. M.Sc. Kukuseva Paneva M.⁵, Prof. Dr. Eng. Dambov R.⁶
 Faculty of Electrical Engineering- Radovish, University 'Goce Delcev'-Stip, Macedonia^{1,3,4,5}
 FNTS- Stip, University 'Goce Delcev'-Stip, Macedonia⁶
 FEIT, University Sv. Kiril and Methodius -Skopje, Macedonia²
 goce.stefanov@ugd.edu.mk, L.Karadinov@feit.ukim.edu.mk, vasilija.sarac@ugd.edu.mk, tatjana.pacemska@ugd.edu.mk, maja.kukuseva@ugd.edu.mk, risto.dambov@ugd.edu.mk

Abstract: Serial resonant bridge converter commonly used in process of induction heating on metal materials. In these applications during the heating process, the converter load equivalent electrical parameters are changed. This contributes to the transferred power from the converter to the induction device to change. In this paper with mathematical analysis is determined the quantities from which depends the active power of the resonant converter. Derived is an equation that gives the dependence of the active power from the phase angle between the voltage and current the converter as and from the duty cycle. This equation can be used in control methods to maintain maximum convertor power transfer.

Keywords: ACTIVE POWER, RESONANT CONVERTER, EQUATION

1. Introduction

In power converters of interest is that the power transferred from the converter on the load to be maximal. Often due to the change in the parameters of the output circuit of the converter, this power is not always maximal [1], [2], [3]. To maintain maximum transferred power from the converter to the load is needed knowledge of the parameters that affect the power. Independent of the type of process controlled by the converter, motor drive or induction device, etc., causes leading to a reduction in the transferred power are related to increasing the phase difference between the voltage and the current of the converter as well the deviation of duty cycle of value 0.5. The change in the phase difference is caused by the change of parameters (inductance, resistance, and capacitance) of the output circuit of the converter. To changing the duty cycle on the output voltage of the converter comes as a result of the need to change the effective value of the output voltage, with target to controlling the output power of the converter. The change on the phase difference leads to an increase in reactive power and a reduction in the active power of the converter. Reduction of the duty cycle from 0.5 increases the harmonic distortion of the output voltage and current of the converter. Both reasons reduced the output active power and efficiency of the converter [4], [5], [6] [7].

In this paper with mathematical analysis are determines the quantities from which depends the active power of the resonant converter. Derived is an equation which gives the dependence of the active power from the phase angle between the voltage and current the converter as and from the duty cycle.

2. Impact on Phase Difference and Duty Cycle at Serial Resonant Bridge Converter

Serial the resonant converter is normally used in the devices for induction heating [1], [2]. In Fig. 1 is shown the electrical scheme of this converter with output load: $R = 0.24 \Omega$, $C = 26.6 \mu\text{F}$ and $L = 26.5 \mu\text{H}$ [8]. In Fig. 2 are shown the output voltage and current waveforms in the more usual above-resonance mode of operation. In induction heating/melting and similar applications the heated workpiece equivalent electrical parameters are part of the resonant circuit. As the work-piece temperature increases, its equivalent resistance and inductance change, thus changing the circuit resonant frequency. Consequently, the deviation of the switching frequency from the resonant one is also changed, which results in undesired change of output power.

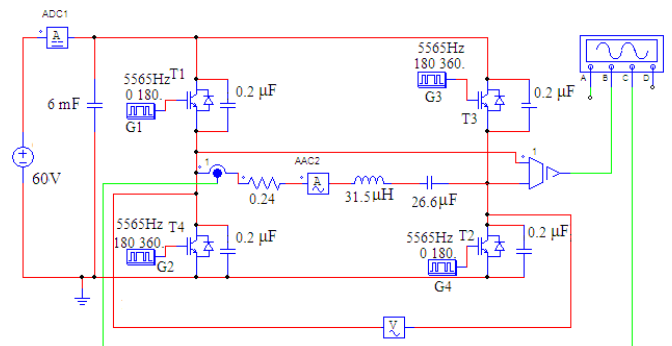

Fig. 1 Serial resonant bridge converter topology in mode of induction device.

The typical R and L change during metal-piece induction melting is in the range of 50%. These real values are used as an example in the following examination giving the values for the resonant frequency $\omega_0 = 37665 \text{ rad/s}$, $f_0 = 5998 \text{ Hz}$ [9], [10].

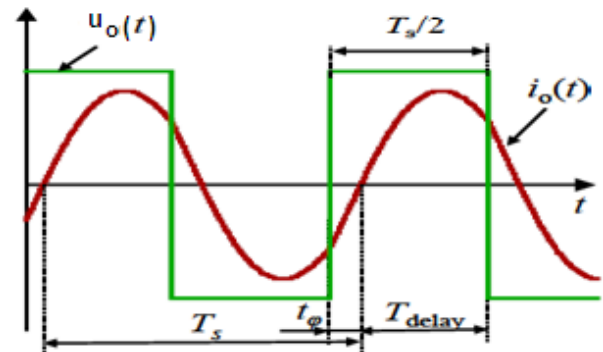

Fig. 2 Output voltage and current waveforms in above-resonance mode.

The mode of induction heating changes the value of the resistance and inductance of the resonant circuit of the converter. This leads to a change in the phase difference between the current and the voltage of the converter and the change of the output power.

In Table I are given the values on the switching frequency f_{sw} , output voltage U_o , output current I_o , output power P_o and phase difference φ for change on the resistance and the inductance for 20%, i.e.: change on R from 0.24Ω on 0.29Ω , and change on L from $26.5 \mu\text{H}$ on $31.5 \mu\text{H}$.

To visualize this rather strange dependence, Fig. 3 gives PowerSim simulation results of steady state for several values of the switching frequency below and above resonance [9].

Table I: Values of the output converter parameters for changes of resistance and inductance for 20%

L [μH]	R [Ω]	φ [$^\circ$]	f_{sw} [kHz]	I_o [A]	U_o [V]	P_o [kVA]
26,5	0,24	5,00	6,27	208	56	10,7
31,5	0,29	31,34	6,27	145	56	6,16

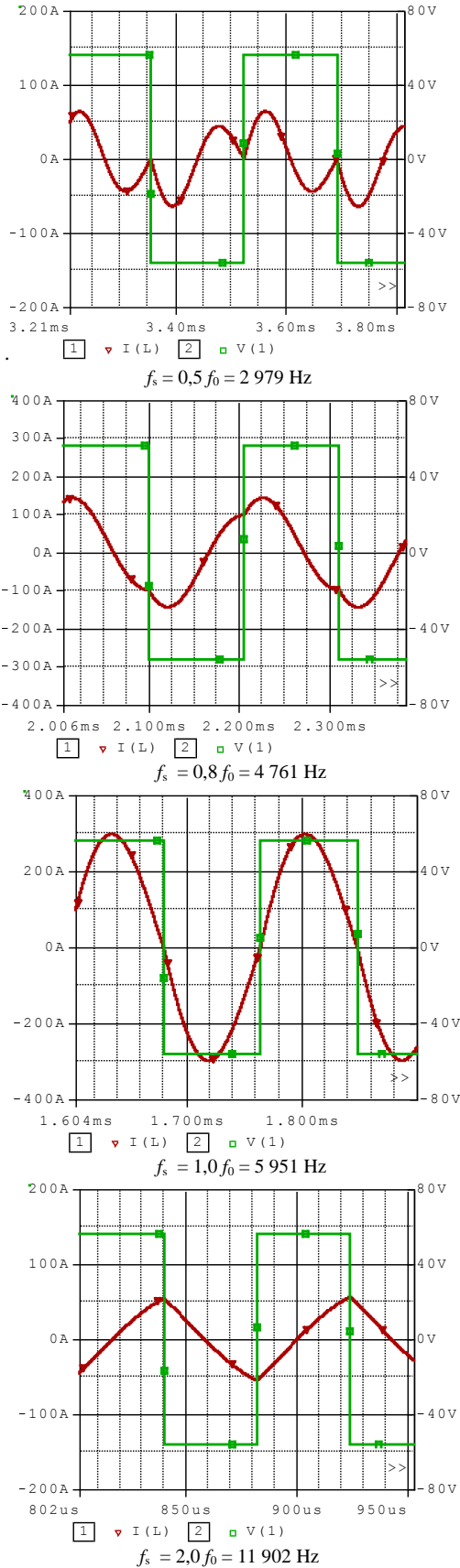

Fig. 3 Steady state voltage and current waveforms below and above resonance ($R = 0.24 \Omega$, $L = 26.5 \mu\text{H}$, $C = 26.6 \mu\text{F}$ and $Q = 4$).

From Table I can be seen that the change in the inductance and the resistance for 20 %, changes the phase angle for 16 % and reduces the output power for 42 %.

The current waveform for $f_s = 0.5f_0$ shows that is very much distorted deep below resonance, the first harmonic is no longer dominant, which reflects to the amount of active power transferred to the load. This explains why below-resonance mode of power control was less desirable. The first diagram in the Fig. 3 for $f_s = 0,5 f_0$ shows that phase difference gets zero values every time the switching period T_s is multiple of the resonant one T_o , in this case $T_s = 2 T_o$.

The general conclusion from Fig. 3 is that when switching frequency f_s is different from resonant frequency f_0 the harmonic distortion of the output current are increased.

In Table II are given the values on output voltage U_o , output current I_{out} , output power P_{out} for change on convertor duty cycle.

Table II: Values of the output converter parameters for changes of the duty cycle

L [μH]	R [Ω]	φ [$^\circ$]	f_s [kHz]	D	I_o [A]	U_o [V]	P_o [kVA]
26,5	0,24	5,00	6,27	0,5	208	56	10,7
26,5	0,24	5,00	6,27	0,4	187	56	8,5
26,5	0,24	5,00	6,27	0,3	125	56	3,8
26,5	0,24	5,00	6,27	0,2	43	56	0,45

From Table II can be seen that the change on the duty cycle D significantly reduces the output power P_o . Changing the duty cycle to 0.1 from optimal value 0.5 causes a change on the power for 21 %. Larger changes in the duty cycle D causes significant changes on the power P_o .

Also, the change in the duty cycle causes an increase in the harmonic distortion of the output voltage. In the Fig. 4 is shown harmonic specter for the output voltage of the converter for duty cycle 0.5 and 0.2.

From Fig. 4a can be see that for duty cycle 0.5 the first harmonic (on frequency 6.027 kHz) has the highest value and for duty cycle 0.2, the highest value has third harmonic, Fig. 4b.

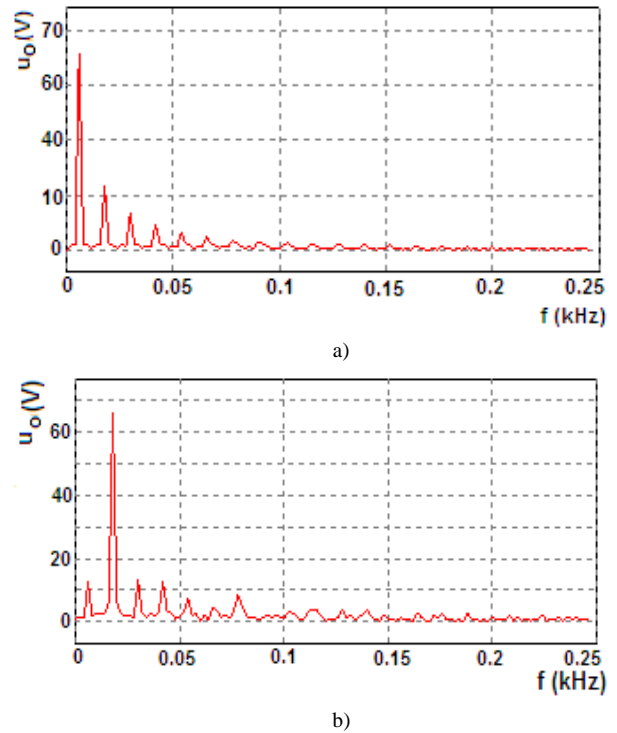

Fig.4 Harmonic specter of the output converter voltage: a) for duty cycle 0.5 and b) for duty cycle 0.2.

The general conclusion from Fig. 4 is that for less duty cycle $D < 0.5$ the harmonic distortion of the output voltage increases.

3. Determination on the active power from phase difference and duty cycle

The output active power of the serial resonant converter is determined as [2], [3]:

$$P_o = U_o I_o PF \quad (1)$$

In (1) U_o is the effective value on the output voltage, I_o is effective value on the output current, and PF is power factor of the converter.

In a converter that generates a voltage with a square waveform at the output, the power factor of the converter is defined as:

$$PF = DF_u \cdot DF_i \cdot DPF \quad (2)$$

In (2) DF_u is a voltage distortion factor and is defined as the ratio of the effective value of the fundamental voltage harmonic U_1 and the effective value of the total voltage U_o , ie:

$$DF_u = \frac{U_1}{U_o} = \frac{1}{\sqrt{1 + THDV^2}} \quad (3)$$

In (3) THDV is a total harmonic distortion of the voltage and is defined as a square root of the ratio of the sum of squares to the effective values of the higher harmonics of the voltage and the square of the effective value of the fundamental harmonic of the voltage U_1 , ie:

$$THDV = \sqrt{\frac{|U_3^2| + |U_5^2| + |U_7^2| + |U_9^2| + |U_{11}^2| + \dots}{|U_1^2|}} \quad (4)$$

The second term in (2), DF_i is a current distortion factor and is defined as the ratio of the effective value of the fundamental current harmonic I_1 and the effective value of the total current I_o , ie:

$$DF_i = \frac{I_1}{I_o} = \frac{1}{\sqrt{1 + THDI^2}} \quad (5)$$

In (5) THDI is a total harmonic distortion of current and is defined as the square root of the ratio of the sum of squares to the effective values of the higher harmonics of current and the square of the effective value of the fundamental current harmonic, ie:

$$THDI = \sqrt{\frac{|I_3^2| + |I_5^2| + |I_7^2| + |I_9^2| + |I_{11}^2| + \dots}{|I_1^2|}} \quad (6)$$

The third term in (2), $DPF = \cos\varphi$ is the displacement factor.

For frequencies close to the resonance, the current is with the sinusoidal waveform, so that the current distortion factor $DF_i = 1$. Based on the above and (1), the power factor in a resonant converter with a square waveform of the output voltage and operating frequencies close to the resonance, is given as:

$$PF = DF_u \cos\varphi = \frac{U_1}{U_o} \cos\varphi \quad (7)$$

In a bridge resonant converter with a square waveform on the output voltage, when the duty cycle is $D = 0.5$, the voltage distortion factor is $DF_u = 0.90$ [2]. With this (7) gets the form:

$$PF = 0.9 \cos\varphi \quad (8)$$

The effective value of the fundamental voltage harmonic U_1 in a bridge resonant converter with a square waveform of the output voltage and the duty cycle factor D is given with [2]:

$$U_1 = \frac{4U_{DC}}{\pi\sqrt{2}} \sin(D\pi) \quad (9)$$

Replacing (9) in (7) for the power factor is obtained:

$$PF = \frac{1}{U_o} \frac{4U_{DC}}{\pi\sqrt{2}} \sin(D\pi) \cos\varphi \quad (10)$$

When the (10) is replaced in (1) the power gets the form:

$$\begin{aligned} P_o &= \frac{I_o U_o}{U_o} \frac{4U_{DC}}{\pi\sqrt{2}} \sin(D\pi) \cos\varphi = \\ &= I_o \frac{4U_{DC}}{\pi\sqrt{2}} \sin(D\pi) \cos\varphi \end{aligned} \quad (11)$$

The equation (11) gives the dependence of the output power of a bridge resonant converter from the output current I_o , the voltage of DC source U_{DC} , the phase difference φ and the duty cycle D .

From (11) can be concluded that the output power of the converter can be controlled with control of the phase difference and with duty cycle D . However, control of the output power with changing the duty cycle D is limited by the increase of the harmonics which comes with a decrease on duty cycle.

When $D < 0.5$ the harmonic distortion increases and the voltage distortion factor $DF_u < 0.90$. For illustration of this, in Fig. 5 is shown the dependence of the voltage distortion factor $DF_u = U_1/U_o$ from duty cycle D .

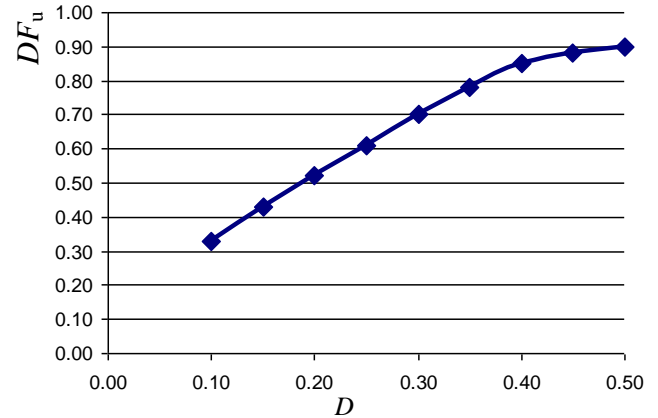

Fig. 5. Dependence of the voltage distortion factor DF_u from duty cycle D .

From Fig. 5 can be noted that to 20% (value 0.4) decrease of the duty cycle, the voltage distortion factor are decreased to 0.85. With this, the power factor will fall below 0.85, the active power will decrease, and therefore the efficiency will decrease. Therefore, in practice when adjusting the output power of the resonant converter by adjusting the duty cycle, it should go with its change in small range below 0.5.

For greater power deviation from the nominal (due to change in resonant circuit resistance) is more practical to use a DC/DC converter in a DC power source that will supply the inverter. However, even considering that the DC/DC efficiency is about 0.9 and the efficiency of the resonant converter is about 0.9 the total efficiency will fall about 0.8.

In serial resonant converter, the output voltage is with square waveform and in such a case phase differences is [8], [10]:

$$\varphi = \arctg \left(\frac{\sin(\pi \frac{\omega_d}{\omega_s})}{e^{\frac{\pi \omega_0}{2Q \omega_s}} + \cos(\pi \frac{\omega_d}{\omega_s})} \right) \quad (12)$$

where:

$$\omega_d = \sqrt{\omega_0^2 - \left(\frac{R}{2L}\right)^2} \quad (13)$$

is damping frequency and with values for $R = 0.24 \Omega$, $C = 26,6 \mu\text{F}$ и $L = 26,5 \mu\text{H}$ has the value 37392 rad/s . When (12) is replaced in (11), for active power of converter is are obtained:

$$P_o = I_o \frac{4U_{DC}}{\pi\sqrt{2}} \sin(D\pi) \cos \left(\arctg \left(\frac{\sin(\pi \frac{\omega_d}{\omega_s})}{e^{+\frac{\pi}{2Q}\omega_s} + \cos(\pi \frac{\omega_d}{\omega_s})} \right) \right) \quad (14)$$

Base on (14) in Table III are given data for the effective value on output current I_o , the voltage on DC supply U_{DC} , ratio on the switching and damping frequency f_s/f_d , the phase difference φ and calculate power P_o . These values are obtain with RLC parameters that are given above.

Table III: Data for f_s/f_d , U_{DC} , I_o , and P_o for $D = 0.5$, $D = 0.4$ and $D = 0.2$

f_s/f_d	U_{DC} [V]	φ [o]	$D= 0.5$		$D= 0.4$		$D= 0.2$	
			I_o [A]	P_o [kW]	I_o [A]	P_o [kW]	I_o [A]	P_o [kW]
0.1	60	-0.02	57	2.88	25	1.26	18	0.91
0.25	60	-0.06	33	1.67	23	1.16	32	1.62
0.3	60	-15.13	62	3.03	52	2.54	34	1.66
0.4	60	20.53	52	2.46	28	1.32	41	1.94
0.5	60	-0.06	42	2.13	41	2.07	41	2.07
0.6	60	-19.72	55	2.62	55	2.62	42	2
0.7	60	-32.56	62	2.64	76	3.24	57	2.43
0.8	60	-37.36	89	3.58	110	4.42	58	2.33
0.9	60	-29.32	157	6.93	155	6.83	47	2.07
1.0	60	0.19	211	10.7	186	9.41	43	2.18
1.1	60	31.10	169	7.32	174	7.54	42	1.82
1.2	60	43.88	129	4.71	128	4.67	33	1.2
1.3	60	47.70	86	2.93	90	3.06	29	0.99
1.4	60	48.17	76	2.57	73	2.46	28	0.95
1.5	60	47.31	62	2.13	62	2.12	26	0.89
1.6	60	45.90	55	1.94	53	1.86	24	0.85
1.7	60	44.29	46	1.67	47	1.70	26	0.94
1.8	60	42.63	41	1.53	44	1.63	23	0.86
1.9	60	40.99	40	1.53	37	1.41	19	0.73
2.0	60	39.42	35	1.37	36	1.40	18	0.7

In the Fig. 6 are shown waveforms of the output power in relation to the normalized circular frequency f_s/f_d obtained with equation (14) for three value of duty cycle: $D = 0.5$ (a), $D = 0.4$ (b) and $D = 0.2$ (c).

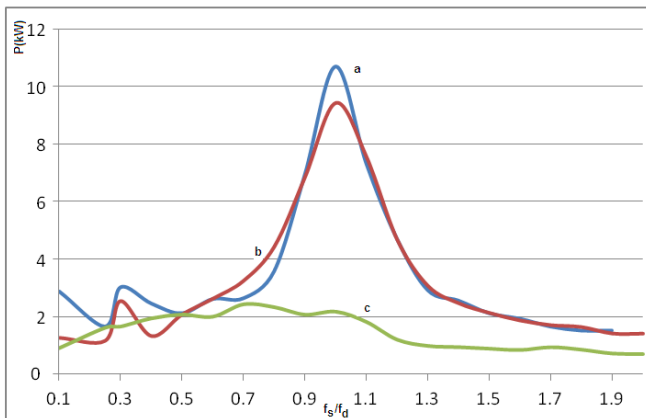

Fig. 6. Waveforms on the output power of the resonant converter for three value on duty cycle: $D = 0.5$, $D = 0.4$ and $D = 0.2$.

Calculating the output power with (14) the effective value on the

output current I_o is obtained with simulation on the circuit from Fig.1 in PowerSim program.

From Table III and Fig. 6 can be seen that: first, the output power is maximal for $f_s = f_d$ and duty cycle $D = 0.5$, second, the output power for $D = 0.4$ and $f_s = f_d$ is reduced for 15 % in ratio on the power for $D = 0.5$.

Also, can be noted that for frequencies larger than $f_s = 1.1 f_d$, the waveforms on the output power for $D = 0.4$ and $D = 0.5$ are almost the same.

The waveform on the output power for $D = 0.2$ shows that in this case is greatly reduced with maximum value for $f_s = 0.7 f_d$.

4. Conclusion

The serial resonant bridge converter have output voltage with square waveform and output current with sinusoidal form when switching frequency is same with the resonant frequency. When this converter operates in mode on induction device RL parameters are changed. This changes cause change on the phase difference between the output voltage and current. This cause change on transferred power from the converter to the output load. On the output power also can be influenced with changes on duty cycle.

To maintain a constant power transfer from the converter to the load, it is necessary to know the dependence of the power on the phase difference and duty cycle. In this paper, an exact equation is derived for the dependence of the output power of the converter from the phase difference and duty cycle. This equation can be used for development of an algorithm for the operation of the converter with constant power.

5. References

- [1] G.E.Totten, Steel Head Treatment, Portland State University, Oregon USA, Second Edition 2006.
- [2] W. B. Williams, Principles and Elements of Power Electronics, University of Strathclyde, Glasgow, 2006.
- [3] W. Shepherd, L. Zhang, *Power Converter Circuits*, Marcel Dekker, 2004, ch.15
- [4] D. Maksimovic, R. Zane, R. Erickson, "Impact of digital control in power electronics", In Proceedings of the IEEE 16th International Symposium on Power Semiconductor Devices and ICs. May: 13–22. 2004.
- [5] K. Harada, Analysis and Design of ZVS-PWM Half-Bridge Converter, IEEE PESC Record, 1995, pp. 280-285.
- [6] J. Shklovski, K. Janson, T. Sakkos, Natural Mode Constant Power Source for Manual Arc Welding, *Elektronika Ir Elektrotehnika*, Vol 18, No 9, 2012.
- [7] Y. Kwon, S. Yoo, D. Hyun, "Half-bridge series resonant inverter for induction heating applications with load-adaptive PFM control strategy", Applied Power Electronics Conference and Exposition, pp. 575–581, Dallas, TX, USA, 14–18 Mar 1999.
- [8] G. Stefanov, "Resonant Converter for Induction Heating of Metals with Improved Efficiency", Ph.D. Thesis, Sts. Cyril and Methodius University, Skopje, Macedonia, 2014.
- [9] PowerSim Software, <http://www.powersim.com/>
- [10] Lj. Karadzinov, G. Stefanov, "Direct phase digital control method in power inverters based on dumping frequency analysis", Proceedings of the 16-th IEEE International Conference on Computer as a Tool – IEEE EUROCON 2015, Salamanca, Spain, 8–11 Sep. 2015, pp. 1–6.